

# SCIENTIFIC AMERICAN

[Entered at the Post Office of New York, N. Y., as Second Class Matter. Copyright, 1902, by Munn & Co.]

Vol. LXXXVI.—No. 25.  
ESTABLISHED 1845.

NEW YORK, JUNE 21, 1902.

\$3.00 A YEAR.  
8 CENTS A COPY



All That is Left of the Library.

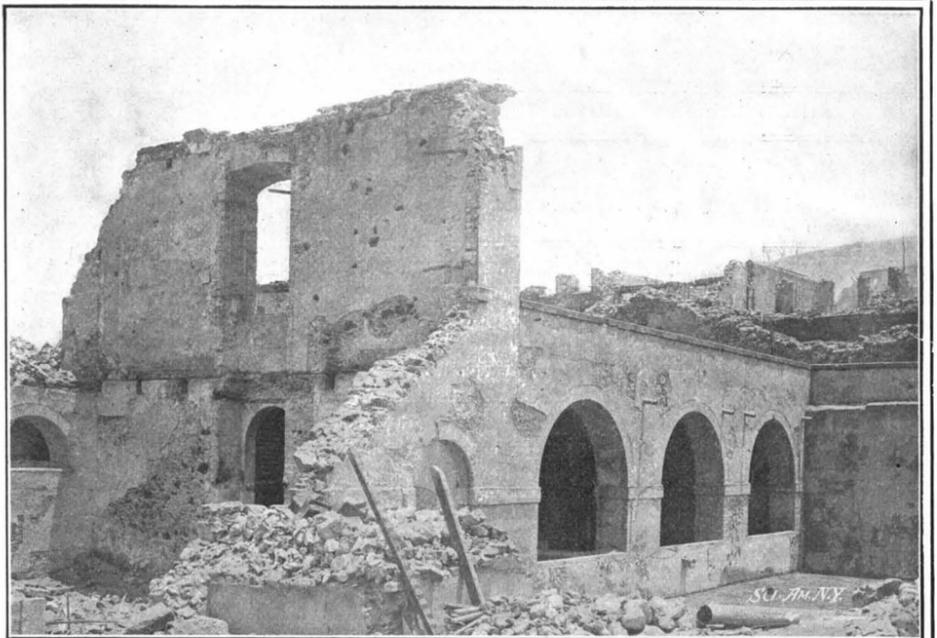

The Mansion of a Wealthy Resident.



A Shattered Tomb.



The Town of St. Pierre Viewed from the South.

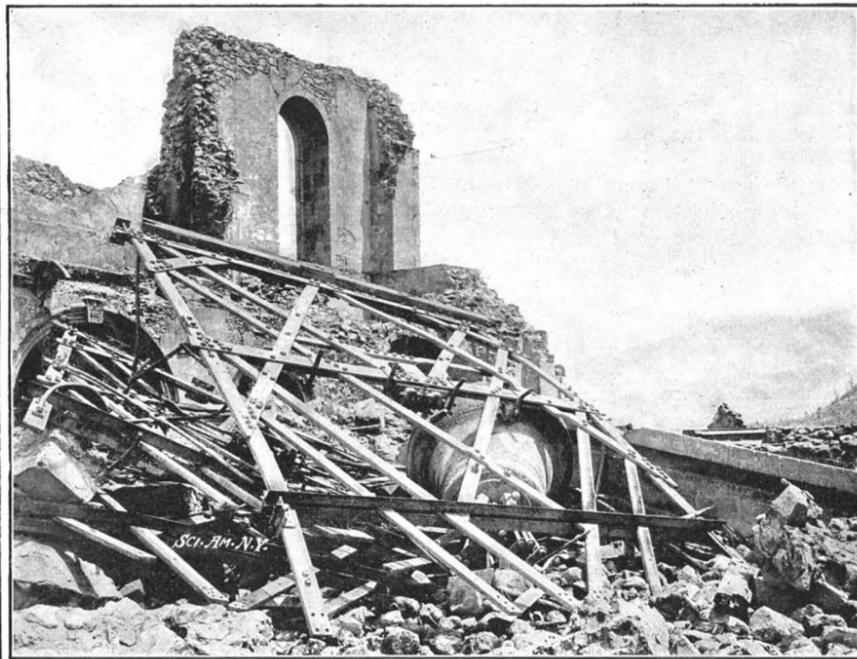

The Dismantled Cathedral and its Bell.

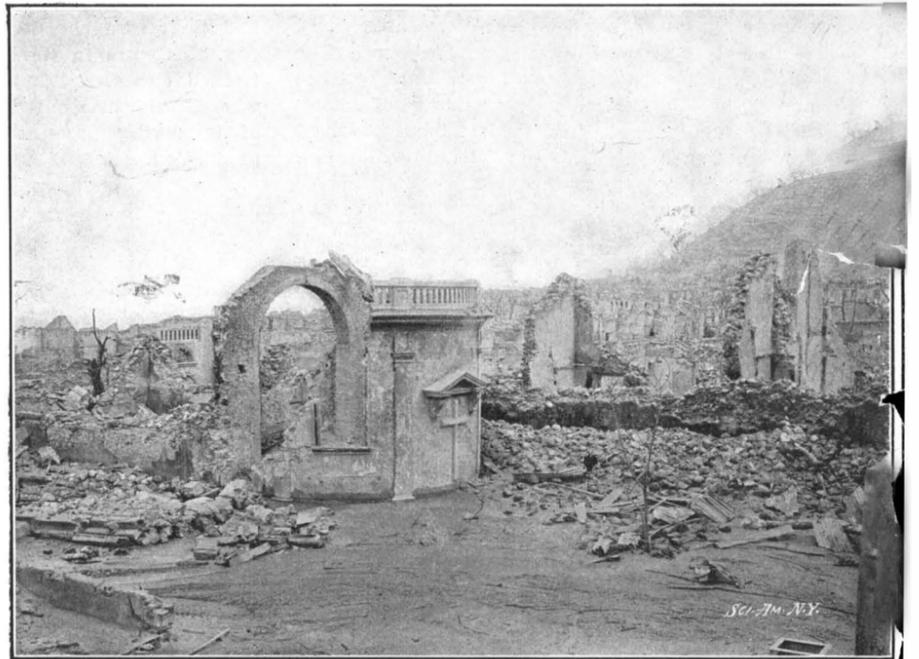

A Street, Looking toward the Cathedral.

Photographs by C. L. King.

THE RUINS OF ST. PIERRE.—[See page 483.]

## SCIENTIFIC AMERICAN

ESTABLISHED 1845

MUNN &amp; CO., - - Editors and Proprietors

Published Weekly at

No. 361 Broadway, New York

## TERMS TO SUBSCRIBERS

One copy, one year for the United States, Canada, or Mexico ..... \$3.00  
 One copy, one year, to any foreign country, postage prepaid. £0 10s. 3d. 4.00

## THE SCIENTIFIC AMERICAN PUBLICATIONS.

Scientific American (Established 1845).....\$3.00 a year  
 Scientific American Supplement (Established 1876)..... 5.00  
 Scientific American Building Monthly (Established 1885)..... 2.50  
 Scientific American Export Edition (Established 1878)..... 3.00

The combined subscription rates and rates to foreign countries will be furnished upon application.

Remit by postal or express money order, or by bank draft or check.

MUNN & CO., 361 Broadway, New York.

NEW YORK, SATURDAY, JUNE 21, 1902.

The Editor is always glad to receive for examination illustrated articles on subjects of timely interest. If the photographs are sharp, the articles short, and the facts authentic, the contributions will receive special attention. Accepted articles will be paid for at regular space rates.

## ANALYSIS OF THE RECENT AUTOMOBILE ENDURANCE TEST AND SPEED TRIALS.

The second endurance test of automobiles in America this year was held under the management of the Automobile Club of America on Decoration Day, and was in every way a success. The weather was fair, and the competitors were aided in their outward journey by a stiff breeze that blew all day from the southwest.

The first machine was sent over the starting line promptly at 9 A. M., and was followed at one-minute intervals by 54 other vehicles. Seventy-four machines had entered, but 19 failed to start. An examination of the Automobile Club's report of the run, which was compiled from the memoranda of the official observers, one of whom was placed on each vehicle, shows the following interesting facts: Of the 55 vehicles that actually started, 44, or 80 per cent, finished within the maximum time limit, which required them to make an average speed of at least 8 miles per hour. The minimum limit of 6 hours and 40 minutes for the course, which was equivalent to an average speed of 15 miles an hour, was not exceeded by any competitor, and there were consequently no disqualifications for racing, as in the previous Long Island test.

Only a little over one-quarter of the machines that started were of the steam type; all the others being gasoline, with the exception of one electric. Eighty-six and two-thirds per cent of the fifteen steam carriages that started finished, and 72 2-3 per cent finished without a penalized stop, while 3 steam Stanhopes, of a well-known make, equipped with condensers, repeated their performance on Long Island, covering the 100 miles without a single stop. The manufacturers of this vehicle seem to have thoroughly demonstrated that the use of a condenser on a steam carriage is entirely practicable, which results in making it possible for vehicles of the steam type to compete hereafter in the long-distance class.

The percentage of gasoline automobiles that finished was but 79 1/2 per cent, while only 43 per cent of those starting in this class finished without a stop. This low average of non-stop gasoline machines was caused, in some degree, by the presence among the contestants of several old or partly experimental vehicles that either did not get very far, or else succeeded in covering the entire course after many breakdowns and tedious waits for repairs. A German Benz machine built five or six years ago was started on a wager that it could not be made to run the 100 miles in 24 hours. The story of its trip is a most interesting recitation of the overcoming of difficulties and repairing of many breakdowns on the road. The vehicle finally arrived at its destination at 2 A. M. the following morning, thus winning the wager, to the great gratification of its plucky chauffeurs. One of the small American motorettes covered the last 80 miles of the journey on the low gear. The operator was forced to do this or else stop and adjust the high-speed clutch. He chose the former, and succeeded in finishing within the time limit, without making a stop. When it is understood that the small De Dion motor used was obliged to run steadily at a speed of 2,000 revolutions per minute for 8 consecutive hours, some idea can be formed of the strength and fine workmanship contained in this light weight bit of mechanism.

Another cause of the low percentage of gasoline vehicles that finished without stops is that several of the best American machines experienced no little trouble with their water-circulating pumps and oiling apparatus. One carriage with fan-cooled motor was a noteworthy exception, and the perfect performance of three machines of this type over a far more difficult course than that on Long Island would appear to indicate that the problem of the medium-sized, air-cooled gasoline motor has at last been solved in a practical manner.

The endurance test, though a comparatively short one, was yet long enough to develop troubles with many of the cars. The steam carriages made the best showing as to perfect runs under the rules, though it should be remembered that the two stops they were allowed for water, fuel, and lubrication were a relief to the operators and the machines which the gasoline cars did not have. Two of the three steam vehicles, that had condensers and made no stops, lost but 6 gallons of water apiece, and the gasoline consumption was but slightly greater. One of the machines consumed only 5 1/4 gallons, or about half as much as most of the other makes, and less by over a gallon than some of the similar two-passenger gasoline machines. The lowest water consumption of a steam carriage without condensers was 71.35 gallons; the average water consumption was 81.33 gallons. The lowest fuel consumption for gasoline vehicles was three gallons.

The one electric vehicle entered in the test succeeded in turning the halfway point (50 miles) with one change of batteries at the first control, or one-third of the entire distance. Shortly afterward it dropped out, since it was not able to run any further. The performance of this carriage is considerably exceeded by the recent run over muddy roads of two English electric touring cars, which traveled successfully from London to Bexhill, a small town on the south coast some 80 miles away. The American manufacturers evidently have much to learn regarding the production of long-distance electric touring vehicles capable of covering 50 miles of cross-country roads on a single battery charge.

The speed trials held on Staten Island May 31 by the Automobile Club of America were brought to an abrupt close by the fatal accident that occurred to the Baker electric racer. The appearance of this machine before and after the accident was depicted in our last issue. Had it succeeded in finishing without accident, it would undoubtedly have made a world's record. As it was, it made a record for electric machines of 36 1-5 seconds for the kilometer (0.621 mile). Other records made were a mile in 1 minute 12 seconds by a Locomobile racer; one in 1 minute 17 3-5 seconds by a Winton medium-weight gasoline machine; and a third in 1 minute 10 2-5 seconds by an Orient motor bicycle.

The endurance test and speed trials have demonstrated that while contests of the former kind can, when properly organized, be held on the public highway without danger to life and limb, all speed trials should take place on a private course, where the spectators, for their own safety, can view the racers from an elevated point, such as a bank or reviewing stand, where their lives will not be endangered by accidents occurring to the contesting vehicles.

## PRACTICAL APPLICATION OF SCIENTIFIC EDUCATION IN GERMANY.

It is the common belief that the commercial rise of Germany has been largely due to the results of the Franco-Prussian war, which put money into its coffers and stimulated the energies of the people. Doubtless much of Germany's phenomenal success of the last quarter of the past century was due to this event; but in order to gage accurately the nation's capacities and aims, it is necessary to look farther back than 1870-71.

It is perhaps unnecessary to say that the whole standard of education in Germany is higher than in either the United States or England, and technical education had its beginning in Germany long before the Franco-Prussian war.

Sixty years ago, Liebig had fifty students working in his factory, and all of the German universities have had their own chemical laboratories since 1827. Today, there are in German factories 4,500 thoroughly trained chemists, besides more than 5,000 assistants, whose brains are constantly at work upon the problems of improving processes, and lessening the cost of production.

The sugar industry illustrates the practical application which the Germans make of their educational system. In 1840 154,000 tons of beet root were crushed, from which 8,000 tons of raw sugar were produced, showing about 5 1/2 per cent of raw sugar extracted from the root. Twenty years later 1,500,000 tons were treated which produced 128,000 tons of sugar, or about 8 per cent. Last year about 12,000,000 tons were crushed, which produced 1,500,000 tons of raw sugar, raising the percentage to 13. This advance is due entirely to scientific treatment.

The production of dry colors, chemicals and dyes in Germany shows a corresponding increase in product and in dividend-paying capacity. Comparing the statistics of the dyeing industry of the year 1874 with those of 1898, it is found that notwithstanding prices in 1898 were considerably lower than in 1874, the net income in 1874 was 24,000,000 marks (about \$6,000,000) and in 1898 was 120,000,000 marks (about \$30,000,000). The great increase of earning capacity is due largely to the constant labor of trained men, who by application of their technical knowledge have so cheapened production that they have succeeded in getting this

trade away from the English, who formerly controlled it. Another illustration is found in the manufacture of artificial indigo, a chemical process for making which was discovered in Germany about thirty-five years ago. It was started with less than forty workmen, all told. It now employs over six thousand men, and has a staff of one hundred and forty-eight scientific chemists. By placing this substitute upon the market at a very low price the Germans have nearly ruined the natural-indigo industry of India.

The Germans have also discovered a method for obtaining ground slag from steel processes, which is used as a fertilizer; and England, although she produces as much steel as Germany, has become a good customer for this article.

A century ago, the English and French makers of scientific instruments were far in advance of the Germans. During the last twenty years all this has changed. The value of the exports from Germany of scientific instruments for the year 1898 was about \$1,250,000—three times what it was in 1888—and the work gave employment to 14,000 people.

The conclusions to be arrived at from the foregoing are not so much academic as economic and practical. In Germany, a young man is called upon to decide, early in his career, whether he will take a classical or a scientific course. If he decides to take the latter he goes into the "Real Schule," or lower scientific school, to be elevated thence to the "Real Gymnasium," or scientific high school, and thence to the "Polytechnicum," or institute of technology, which is separate from the universities. In this course he learns no Greek and only a moderate amount of Latin; but he has the sciences, engineering, mathematics, modern languages, history and a mixture of practical and theoretical training in various technical branches, with frequent excursions for the purpose of inspection of work in factories and public enterprises.

The faculties of these institutions keep in touch with the manufactories, and when capable young men graduate they easily find situations. This is also true of the technical high schools, of which there are twenty-four, which likewise have courses in engineering, architecture, drainage, irrigation, modeling, drawing, chemistry, modern languages, history, etc.

The questions for the people of the United States are: Is our system of education as perfected as it should be? Have we sufficient scientific education of the best grade and are our educational institutions in close enough touch with the manufactories to supply their needs? If not, are we not hampered in competition with our great commercial rival, which enjoys this complete co-operation?

The Imperial Department of Commerce and Industries has been of great assistance to the German manufacturer. It has been an intermediary between the educational and practical work, guiding the one, sustaining the other, and furnishing information to the manufacturer, first in beginning his industry, later in expanding it, and finally in marketing his surplus.

We should not rely too much on our unrivaled natural resources in the struggle for foreign trade. No country can rest in fancied security. What is the cheapest and best to-day may be made cheaper and better by our rival to-morrow, with its human plant of half a hundred thousand trained scientific brains working daily and steadfastly.

## RICHARD L. MADDOX, M.D.

It is probable that very few photographers are familiar with the name of Dr. Maddox, who died on May 11 last in Southampton, England, at the age of 85. He was, however, regarded as the inventor of the gelatino-bromide process now so universally used. The process was improved after him by Kennett, Burgess and Bennett. Dr. Maddox prior to the seventies was particularly interested in photo-micrography, and found the work of drawing the enlarged images so vexatious that he looked about to see what could be done in the line of photography. He learned the practice of the collodion wet-plate process, and worked with that for a while. But the small darkroom he used soon became so saturated with ether evaporating from the collodion that it seriously affected his head and health. He then determined to try and ascertain a substitute for the collodion, and made an emulsion of isinglass, gelatine and other materials.

His experiments resulted successfully, for in 1871 he prepared a gelatino-bromide of silver emulsion and coated it upon glass plates, exposed them in a camera, securing very good negatives. These original negatives were placed on exhibition at the Inventions Exhibition in London in 1885, and he was awarded a gold medal therefor.

In 1889 he was awarded the Scott medal of the Franklin Institute at Philadelphia, and in 1901 he was awarded the Progress medal of the Royal Photographic Society of London, in each case in honor of his early work in the production of a practical gelatino-bromide process.

In 1892 a special fund was raised for his benefit of about \$2,000 through the efforts of Sir William

Abney and others, "in recognition of his services to photography, and especially of his investigations in connection with gelatine emulsion." Like a true amateur and investigator, he pursued his experiments for the pure love of them, without any desire of pecuniary reward or with a thought of keeping the process secret, and for this his memory will be held in high esteem by succeeding generations of photographers.

#### THE DEVELOPMENT OF THE SAULT STE. MARIE CANAL.

BY WILLIAM GILBERT IRWIN.

Few save those directly or indirectly interested in the commerce of the Great Lakes fully realize the import upon the various lines of industrial endeavor of the traffic of our great inland seas. In no other way is the magnitude of this internal shipping so fittingly exemplified as in the immense tonnage which annually passes through the Sault Ste. Marie canal, which forms that important artificial waterway which obviates the natural barrier between Lake Huron and Lake Superior, and thus opens up to interlake shipping the greatest link in the world's greatest chain of unsalted seas.

Aside from establishing Duluth as a most important point of shipping, this great canal has been responsible for the marvelous agricultural, commercial, industrial and mineral development of the great Northwest through providing cheap water transportation facilities to the Atlantic. Through the wonderful development of the iron ores the canal has been a factor in establishing the industrial prestige of Pittsburg and other iron and steel manufacturing centers. In fact, no similar expenditure of capital by any state or any nation has conferred such vast benefits to a wide area and to so extensive a population.

The time has come when the accomplishments of the human race in the wide domain of commerce and industry are no longer subordinated to the enactments of war and conquest, and for some time important events in the peaceful fields of industry have been marked by exhibitions of work along these lines. The observance of the beginning of the work which resulted in the construction of this great canal is to be appropriately observed, and although it has not yet been decided just when this event is to be celebrated, there is at this time a bill before Congress for an appropriation for this purpose.

So far as concerns the American canal, the idea was first originated by Gov. Mason, of Michigan, in his message to the Legislature in 1837, the year after Michigan was admitted to the Union. On March 21, 1837, the Legislature of that State passed an act authorizing a survey and appropriating \$25,000 for the work. This original survey, made under the direction of John Almy, recommended a canal 75 feet wide and 10 feet deep, with two locks, each 100 feet long, 32 feet wide, and 10 feet deep, the estimated cost of the work being \$112,544. On September 7, 1838, the State of Michigan entered into a contract for the construction of the canal with Messrs. Smith & Driggs, of Buffalo. Work was not begun until May, 1839, and was soon suspended owing to a clash between the United States military authorities and the contractors, which resulted in the ejection of the latter, and thus ended the first attempt at canal-making at this point.

On March 27, 1840, the Michigan Legislature passed a joint resolution protesting against Federal interference with the work, and three days later a memorial on the subject was forwarded to Congress, in which body a bill granting 100,000 acres of land to aid the work of constructing the canal was introduced. The matter rested until 1843, when the Michigan Legislature asked Congress for an appropriation, similar resolutions being passed by that body in 1844 and 1848. In the meantime the copper industry of the Lake Superior region had assumed great importance. In 1849 the State Legislature asked Congress for a cash appropriation of \$500,000 for the canal, and finally a bill was passed by Congress and approved by President Pierce on August 26, 1852, by which a grant of 750,000 acres of land was made to assist in constructing the canal. Whether this event or the actual beginning of work on the canal will form the date of the celebration is a matter not yet decided by those in charge of the matter.

Immediately upon the passage of the Act of Congress relative to the land grant for the canal, Gov. McClelland, of Michigan, secured the services of Capt. Canfield, of the United States Topographical Survey, to make a survey for the proposed canal. An Act of the Michigan Legislature, approved by the Governor on February 12, 1853, provided for a canal commission, to which Chauncey Joslin, Henry Ledyard, John P. Barry, Shubael Conant, and Alfred Williamson were appointed. On April 5, 1853, the commissioners entered into a contract with Joseph Fairbanks, J. W. Brooks, Erastus Corning, August Belmont, H. Dwight, Jr., and Thomas Ryer as principals, and Franklin Moore, George F. Potter, John Owen, James F. Joy, and Henry P. Baldwin as sureties, for the construction

of the canal, the contractors agreeing to build the canal and defray all expenses for the 750,000 acres of land appropriated by the Federal government.

As the Constitution of the State of Michigan contained a provision which forbade all special charters, the St. Mary's Falls Ship Canal Company, with a capital of \$1,000,000, was chartered under the laws of New York, the company organizing with Erastus Corning as president, James W. Brooks vice-president, J. V. L. Prior secretary and treasurer, and Erastus Corning, J. W. Brooks, J. V. L. Prior, Joseph Fairbanks, John F. Seymour, and James F. Joy directors. While the original contract was not assigned to this company until August 25, 1853, ground was broken on the canal on June 4, 1853, by Charles T. Harvey, under whose supervision was constructed the original "Soo" canal, a work which has resulted in opening a vast domain and conferred untold wealth upon a wide section of our country.

Work upon this original canal was conducted with vigor, and on May 21, 1855, a certificate of the completion of the work was signed by Kinsley S. Bingham, then Governor of Michigan, and the members of the canal commission. A certificate to the same effect was made on May 21, 1855, by James T. Clark, engineer, and these two certificates were filed with the Commissioner of the State Land Office on May 24, 1855, and the following day the land appropriated by the general government for the canal work was patented to the St. Mary's Falls Ship Canal Company. This canal was 5,750 feet long, 64 feet wide at the bottom and 100 feet at the water surface, and 13 feet deep. There were two tandem locks of masonry, each 350 feet by 70 feet by 11½ feet on the miter-sills, with a lift of about 9 feet each, and the entire cost was \$999,802.46.

Water was first let into the canal on April 19, 1855, and on June 18 following, the first boat passed through the canal, and thus was inaugurated intercommunication between Lake Superior and the others of the Great Lakes. Upon the completion of the canal it passed into control of the State of Michigan, the Governor, Auditor-General and State Treasurer constituting a Board of Control, John Burt being appointed the first superintendent of the canal. The canal remained under State control until 1872; and the old locks, which were built of Ohio limestone, remained in use until 1888, when they were destroyed by the excavations for the Poe lock in 1888.

Upon the transfer of the canal to the Federal government, Gen. O. M. Poe, then in charge of that district, assumed control of the waterway, being relieved by Gen. Godfrey C. Weitzel on May 1, 1873. Under Gen. Weitzel's supervision was built the lock which bears his name. This lock is 515 feet long, 80 feet wide in chamber, narrowing to 60 feet at the gates, with 17 feet of water over the miter-sills, and it was built between the years 1873 and 1881 at a cost of approximately \$3,000,000, including the deepening and widening of the canal. Plans now being formulated by the Federal authorities will increase the Weitzel lock so that it will have a length of 1,600 feet, a width of 100 feet and a depth over miter-sills of 30 feet, these improvements to cost nearly \$25,000,000.

The Poe lock, which was originally surveyed by Gen. O. M. Poe, is 800 feet long, 100 feet wide, and 22 feet over miter-sills. It was built between 1887 and 1896 at a cost of a little over \$4,000,000. The canal has been deepened to 25 feet, and the entrance piers extended so that its total present length is 8,448 feet. The channel through the St. Mary's River is now 20 feet deep at the mean stage of water and 300 feet wide, and the whole improvements on the American side up to date aggregate something over \$15,000,000.

While electricity is used for operating the Canadian lock, both the Poe and Weitzel locks use hydraulic power, a pressure of 400 pounds per square inch being used for the former lock and 115 pounds for the latter. The Poe lock can be filled and emptied in about 7 minutes, and an up-lockage of a boat 350 feet long can be made in 11 minutes, the gates being opened or closed in 2¼ minutes.

Canal work on the Canadian side began some time between the years 1796 and 1798, when the Hudson Bay Fur Company built a lock 38 feet long, 8 feet 9 inches wide, with a lift of 9 feet. A towpath was made along the shore for oxen to pull the bateaux and canoes through the upper part of the rapids. This old lock was demolished in 1814 by United States troops from Mackinaw Island under command of Major Holmes. The present Canadian canal is 5,920 feet long, 150 feet wide and 22 feet deep, with a lock 900 feet long, 60 feet wide, and 22 feet of water on the miter-sills. It was built between the years 1888 and 1895, the work being in charge of W. G. McNeil; Thompson, Ryan & Haney being the contractors. The canal cost \$4,000,000.

During the first season of the original American canal a registered tonnage of 106,296 tons passed through the canal. Until 1864 no record was kept of the number of vessels passing through the canal, but in that year there were 1,411 lockages, with an agree-

gate tonnage of 571,438 tons. In 1870, 1,828 vessels passed through the canal, and their aggregate cargo was 690,826 tons, while in 1875, 2,033 vessels passed through the canal, and they carried 1,260,000 tons of cargo. The traffic of the canal in 1880 amounted to 3,503 lockages and 1,735,000 registered tons.

The development of the shipping on the Great Lakes was so rapid during the next few years that in 1884 but 11 per cent of the vessels passing through the Weitzel lock could have used the old canal. In 1885, 5,380 vessels passed through the canal, carrying more than 3,000,000 tons of freight; and in 1890 this had increased to 10,557 vessels, carrying 8,500,000 tons. In 1895, during part of which season the Poe lock was open, 17,956 vessels, carrying 16,806,781 tons of freight, passed through the canal. In 1900, during which year the American canal was open to navigation 231 days, a total of 19,432 vessels, carrying a registered tonnage of 22,315,834 and a net freight tonnage of 25,643,073 tons, passed through the American and Canadian canals, of which traffic fully 90 per cent passed through the American canal. The traffic for both canals for 1901 amounted to 20,041 vessels, with a registered tonnage of 24,626,976 and a net freight tonnage of 28,403,065. The value of this freight was \$289,906,865. Navigation for the present year on the American canal opened on April 5, and for April 1,303 vessels carrying a registered tonnage of 2,067,046 tons, passed through the canal, while the Canadian canal, which opened on April 1, shows a traffic for April of 376 vessels, with a registered tonnage of 255,833 tons.

The American "Soo" canal, which is open to navigation only about eight months in the year, has more than four times the annual traffic of the Suez canal. During the past few years the vessels passing through the "Soo" canal have averaged one for every fifteen minutes day and night. Few works of man portray more fittingly the spirit of this age of industrialism, and of great achievements in production and distribution as does this, the world's greatest canal, which has about completed the first fifty years of its existence.

#### MAKING FIFTY-TON ANCHOR CHAINS.

BY DAY ALLEN WILLEY.

What are claimed to be the largest chains ever made in this country for securing a ship's anchors have been manufactured at the Lebanon Chain Works, of Lebanon, Pa., for the Newhall Chain Forge and Iron Company. They are intended for the steamships being constructed at the plant of the Great Northern Steamship Company, and to bend and join the links special machinery was designed by Eli Atwood, general manager of the works. They were made in four sections or "shots," each comprising 990 feet, so that the total length of the combined chains is nearly 4,000 feet. Two will be supplied each ship, one for the starboard and one for the port anchor, but for convenience in handling and construction each chain is subdivided into shots of 90 or 180 feet joined by swivel shackles.

The material employed was the highest grade of chain iron, drawn out in bars 3 7-16 inches thick for the shackles and 3 3-16 inches for the links. In manufacturing the links the bars were cut or sheared into the requisite lengths, then heated in a special furnace. The bending machine, which is operated by steam power, holds what might be called a model or die of steel of the same shape and size as the opening in the center of the link. The bar, while white hot, was drawn into shape by the jaws of the bender, enough space being left between the ends to insert the two links connecting with it. After the process the ends were "side welded" by hand in the smith shop. As each link ranges between 19 and 20 inches in length, the lengths cut for bars are nearly four feet in dimensions.

To hold the weight of the various sections during the welding and shackling processes, also to stow the complete chain, a series of metal blocks and tackles were employed to which large hooks were bolted. The chains connected with the blocks are operated by trolleys sliding along a track fastened to the frame of the shop roof.

A portion of the completed chain was tested by apparatus installed at the Lebanon Works, which is said to be the largest chain-testing machine in this country, having a capacity of 600,000 pounds. At a strain of 500,000 pounds the jaw of the holding shackle of the machine was broken, but none of the links were affected. At the second test the breaking strain was placed at 549,000 pounds, when the jaw of the machine feeding the oil to the tester was fractured. The chain itself, however, was unaffected. These figures are 55,000 pounds above Lloyd's requirements for such anchor chains.

A further illustration of the great size of the chains can be given when it is stated that each link averages not less than 165 pounds weight, an average of about 100 pounds to the running foot, making the total weight of each anchor section nearly 50 tons. The chains, of course, will be handled in connection with their respective anchors by steam power, either communicated to large winches or to special stationary engines.

## SILKWORM CULTURE IN AMERICA.

BY WALDON FAWCETT.

The movement recently inaugurated by the Department of Agriculture looking to a revival of the silk-worm industry in America bids fair to prove in a considerable measure successful. That some portions of the United States are well adapted to silk culture has been conclusively demonstrated; and particularly is this true of the Southern States, where not only are climatic and other conditions favorable, but there is available some of the cheapest labor to be found any-

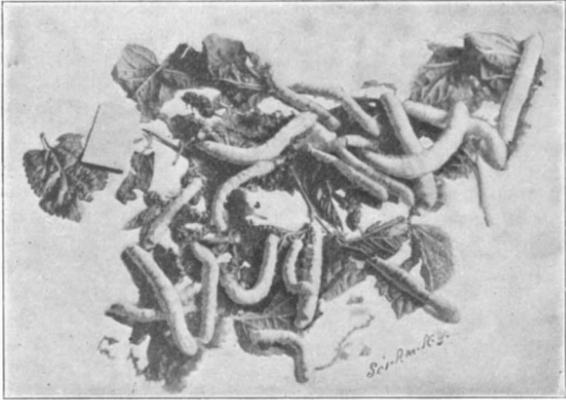

SILKWORMS AND MULBERRY LEAVES

where in the world—a most essential requisite for competition with the foreign silk-producing countries with their facilities for obtaining a minimum cost of production.

Silk culture ranks as one of the comparatively few activities which having once gained a foothold on this continent was allowed to languish and practically disappear. The industry was started in America in 1622 when James I. sought to foster the industry in Virginia. He sent out to the colony silkworm eggs and mulberry trees, and offered premiums for colonial silk, but after brief experiments the planters returned to the cultivation of tobacco. In Carolina and Georgia, however, the effort was more successful. Silkworms were brought by the first settlers and the industry speedily took root, flourishing for more than a quarter of a century, during all which time these two colonies exported considerable silk to London. In 1750 a silk-reeling mill was established at Savannah, and in 1759 the exports of raw silk from that port alone showed an aggregate valuation of \$75,000.

The Huguenots who settled in the vicinity of Charleston, S. C., in 1677 had also taken up silk culture almost from the date of the establishment of their new home, and for nearly a century from \$5,000 to



REELING SILK.

\$10,000 worth of silk was annually exported from Charleston, in addition to which a considerable amount was woven and consumed at home. The Revolutionary war had a blighting effect upon the silk industry in all parts of the South, although during the conflict the raw material was made into sewing silk and sold in the home market. Henceforth, however, the history of the industry in the New World was shifted to the more northerly colonies.

The colony of Connecticut was the scene of experiments in silkworm culture as early as 1760, and within a decade after that the industry had also taken root in a small way in New York, Pennsylvania, New Jersey, Rhode Island and Massachusetts. In all these colonies the industry was seriously affected by the War for Independence, but at its close a greater effort



THE SILKWORM RACKS.

was made for its revival than was the case in the Southern States. Connecticut in 1783 offered a bounty to silk growers and thus attained to first rank in the amount of silk produced, a place which she held for four-score years, and in Pennsylvania Benjamin Franklin and other public-spirited citizens interested themselves in the restoration of the industry. Silk growing became popular in all the States on the Atlantic seaboard, and the Connecticut output reached a valuation of \$200,000 a year, but during the years between 1838 and 1844 large nurseries of Chinese mulberry were planted, and there set in that speculative craze that in the end proved the ruination of the industry. For a time yearling trees sold for prices ranging from \$3 to \$4 each, but in the winter of 1844 a severe frost destroyed hundreds of thousands of the young trees. Instantly the speculation collapsed. Hundreds of silk growers who had purchased trees at fancy prices were ruined and the entire industry received a setback from which it never recovered. It was suggested that the New England silk growers plant a hardier variety of mulberry and retrieve their fortunes, but they preferred to turn their attention to silk weaving, using imported raw silk, and silkworm culture was allowed to languish.

The practical investigation of silk culture by the United States Department of Agriculture began as the result of an agitation of the subject dating from the Centennial Exposition of 1876 and was carried on by virtue of specific appropriations by Congress, continuing, practically, from 1884 to June 30, 1891. The experiments, which were conducted on an extensive scale, the work being under the supervision of the Division of Entomology, established the possibility of raising a most excellent quality of silkworm cocoons over nearly the entire country, but also disclosed the one great obstacle to the industry as a profitable enterprise, namely, the difficulty of finding labor in the United States to compete with the low-priced labor of foreign silk-raising countries in the operation of reeling or converting the cocoons into raw silk. All the later work of the Department has, therefore, been especially directed to efforts to remedy this state of affairs and to equalize by improved machinery the difference in wages between this and foreign countries, thus making it possible for the manufacturer to pay a better price for cocoons. Electric silk reels and other devices have been introduced, but even with such adjuncts there is little likelihood that the industry will be made a highly profitable one unless a heavy import duty is imposed on reeled silk imported into the United States—a rather unlikely procedure it must be admitted.

For years past silk culture has been carried on in a modest manner in various parts of the country. In Utah, for instance, there are a number of people who are raising silkworms from year to year, growing mulberry leaves for their food and actually producing silk and weaving it into cloths for family use. Mrs. Carrie Williams, of San Diego, Cal., has been

engaged in the industry in a small way for some years past, and Dr. W. H. Hill has at Peoria, Ill., an institution from which over 1,000,000 silkworms are shipped annually.

As has been stated the greatest obstacle to be overcome in the establishment of the industry of silk culture in the United States is found in the labor problem, and it is for this reason that the friends of silk culture look with an especial degree of hope to the field presented by the Southern States now awakening to industrial activity. Raw silk is, it is true, the product of the cheapest labor in foreign countries, but no country has cheaper labor than is available in the Southern States. Children who are unable to do heavy field work can be employed; and, moreover, the entire task may be attended to in April and May when there is no cotton picking. What makes the plan appear especially feasible is the seemingly parallel circumstances which are found in the tea-raising industry in the South. It has been demonstrated within the past few years that tea can be grown profitably in the South, the leaves being gathered by children whose parents are delighted with the addition made by these earnings to the family income. This class of labor can, of course, be employed to pick mulberry leaves and feed silkworms. Another great advantage which will be enjoyed by the people of the Southern States in the raising of silkworms is found in the inexhaustible supply of leaves of the Osage orange which is available in that section of the country. The Osage orange leaves have been found to be as good food for silkworms as mulberry leaves and the silk produced on this diet is of the finest quality. Thus there is removed all possibility of a repetition of the losses which ruined the American silk culture industry.

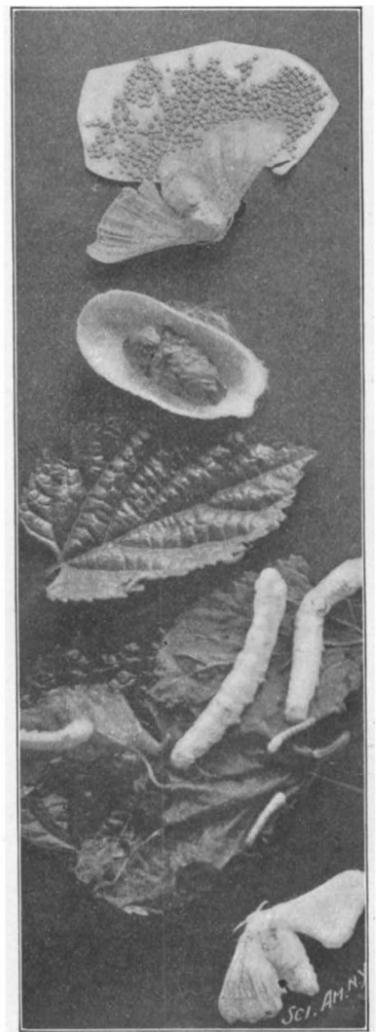

STAGES OF SILKWORM GROWTH.

during the first half of the last century, and finally, an abundance of Osage orange hedges obviates the necessity for any expenditure whatever in cultivation.

The silkworm is, of course, the larva of a moth. There are several species, but one variety has been under general cultivation for centuries. The silkworm



AN INSECT CAUGHT IN THE TENTACLES OF *DROSERA ROTUNDIFOLIA*.

eggs are nearly spherical and about the size of turnip seeds. Each female produces an average of from 300 to 400 eggs, in the neighborhood of 20,000 eggs being required to make an ounce in weight. For a time after the infant worm has gnawed its way out it consumes its own weight of leaves every day. Upon attaining full growth the insect becomes restless, stops feeding and throws out silken threads. The silk is formed in a fluid condition and issues from the body of the worm in a glutinous state—apparently in a single thread. From this silk the worm constructs its cocoon, an interval of from three to five days being required to complete its imprisonment in the fragile envelope.

In order that the silken strands may not be subjected to the danger of breakage by the moth emerging from the cocoon, the cocoons are steamed until the inclosed insects are presumably dead. After this the silk may be wound off. The outer silk known as "floss" is used for carding, while the inner cocoon is tough, strong and compact and composed of a single continuous thread. It is essential that the room in which the silkworms are reared be warm in winter and well ventilated. If only a few insects are reared all the operations are usually performed on trays set on tables, but where the industry is carried on extensively there are employed deep shelves ranged one above another. The eggs when about to hatch are spread thinly and over them is placed ordinary mosquito netting on top of which is scattered finely cut leaves. The new-born worms pass through the meshes of the net in search of food and may then be transferred to any place desired. Later little arches of twigs must be provided, into the branches of which the worms mount and spin their cocoons.

REFLEX ACTION OF PLANTS AS COMPARED WITH THE INSTINCTS OF INSECTS.

BY J. CARTER BEARD.

We have all of us been so accustomed to wonderful stories of the wisdom of ants and of bees, as well as

other worthy members of entomological races, that the doubts which certain scientific investigators are beginning to entertain with regard to the truth of any assertion that attributes conscious intelligence to these little creatures, comes upon our sentimental appreciation of their ways with something like a shock.

When we consider the wonderful adaptation of means to an end, the prevision and the ingenious methods employed by many sorts of insects in carrying out the purposes and objects of their lives, we are indeed inclined to credit them with intelligence of a high order. It is only after we are forced to recognize the extreme limitations of this so-called intelligence, its inflexible nature, and its inability to adapt itself to other conditions than those under which it is habitually, or ordinarily exercised, that we recognize how much is wanting in the behavior of insects to furnish conclusive evidence of their possession of any intellectual capacity whatever.

Light, for example, attracts insects in general, as it does also plants, but it does not necessarily follow that vision, in the human sense of the word, belongs either to plants or to insects.

The attraction of light governs the growth, the inclination of stems and the position of leaves; the plant reaches, so to express it, out toward the light with all the power it has—yet it does not see. The insect has eyes or organs of vision (quite different from ours), but all we absolutely know about insects is that they are influenced by light, and to aver, without more definite knowledge on the subject, that they do anything so highly psychical as seeing (as human beings see) is not only unscientific, but not at all consistent with well ascertained facts. How unintelligent is the impulse the insect shares with the plant in seeking the light, is shown by the inane manner in which moths or beetles will flutter about a white ceiling, or plunge into a flame.

Intelligence does, indeed, direct the actions of the bee in building her comb and filling it with honey, and

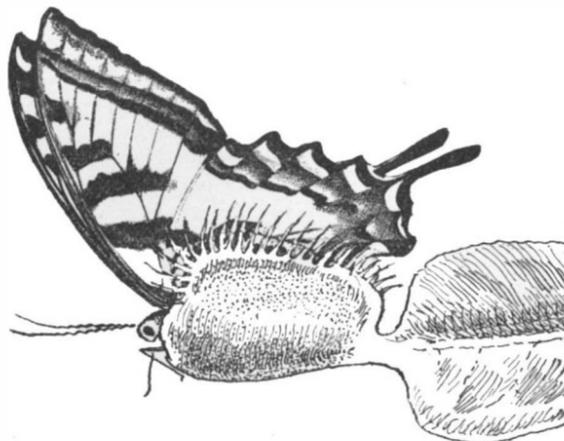

A BUTTERFLY CAUGHT IN THE TRAP.

the ant in her wonderful domestic economy; but it is an intelligence quite as much above the plane of consciousness of the bee and of the ant, as it is above that of the orchid, for instance, in the admirably ingenious manner in which the flower enlists the aid of the insect in conveying pollen. Reflex actions of this kind mimic intelligence on the part of the actor, something perhaps as do the movements of the boat, said to have been invented by Tesla, which, worked by etheric waves, proceeds in any given direction, turns or dives beneath the surface of the water upon which it floats, not in obedience to any directing power on board, but at the will of a person operating a battery on the shore.

The stimuli of whatever nature, light, heat, some form of electric action, magnetism, or even more subtle, occult forces which move insects, seem to have the unvarying and unthinking nature of those supplied to mere machinery; the result is much the same as in an automaton, blind perseverance in a certain limited number of actions it is designed to perform.

Take from the cell excavated by a digger wasp, the grasshopper she has placed there, and upon which she has laid her egg, and the wasp, after entering and exploring the cell, will, instead of restocking it and laying another egg, calmly close it up, just as she would have done had it not been robbed.

Cut off the antennæ by which the wasp (*Sphex maxillosus*) drags a cricket to her burrow, and *Sphex*, unable to get her accustomed grip, leaves her quarry, and goes off in search of crickets which have not lost their antennæ. It does not occur to her that the creature has legs as well as antennæ.

The sand wasp (*Bembex*) can unerringly return to the entrance to her cell from the distance of a mile or more, over a featureless sandbank, and although her burrow is covered over with sand, and to human eyes entirely indistinguishable from the parts surrounding it, the wasp can alight upon the exact spot, scratch away the sand and enter the nest; but remove the surface, exposing the cell and the larvæ,

and *Bembex* is entirely at a loss, unable to recognize either her own nest or her own offspring. Nothing can more perfectly show how an interaction of forces, without a conscious, directing intelligence, can, in a certain particular way, achieve a marvelous result,

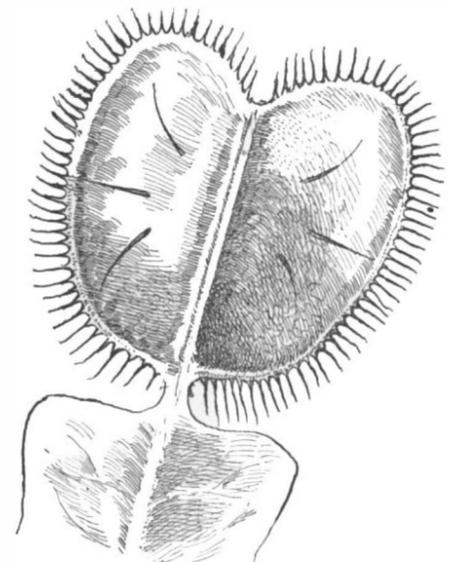

VENUS' FLYTRAP, OPEN.

while in every other, it results in confusion and failure. The unusual happens, and an organism constituted as is the *Bembex*, is thrown out of gear, much as would be a machine in which a cog-wheel has failed to engage the answering cogs of another wheel.

There are in plants fully as many ingenious devices to attain some desired end, and as many adaptations to special environments, perhaps, as among insects. Plants, however, rooted as they are to one spot and in general incapable of movement, exhibit contrivance in the only way left them to do so, in their habits of growth, and in the form and arrangement of their parts, as seen, for instance, in the manner in which many provide for the distribution of their seed, and the inventive faculty, so to speak, shown in the modifications of form in orchids to secure fertilization. I say in general incapable of movement, because the rule admits of very notable exceptions.

In the telegraph plant (*Desmodium gyrans*) of India, of the three leaflets of which each of its leaves are composed, the larger terminal one erects itself during the day, and turns sharply down at night, while the other two smaller leaflets move constantly day and night, describing complete circles with a peculiar jerking motion like the second hand of a watch. Occasionally they rest for a period and then go on again, thus bringing every part of every leaf to the full action of the sunlight.

Many plants shift the position of their leaves as the direction of the light changes. This power is possessed to a considerable degree by some of our common house plants. If an oxalis shrub, for instance, is exposed for a time to the light in a window, and then turned half way around, an observer can by watching, see the leaves readjust themselves to their new position in relation to the light. Certain movements of plants seem to testify to the possession by the plants of something answering to the tactile sense in animals. A number of plants besides the common sensitive plant, exhibit apparent sensibility to external impressions and manifest also the power of transmitting the perception of these impressions from one part of the plant to another. In addition to this power, there are plants which possess a power of discrimination that certainly seems to have as just a claim to being called intelligent as are the actions of some insects.

If a drop of water, or a grain of sand, falls upon the gland-studded leaves of the sundew (*Drosera*), nothing more happens than as if they had been dropped upon the leaf of any ordinary plant; but let an insect or a bit of meat take



SUNDEW.

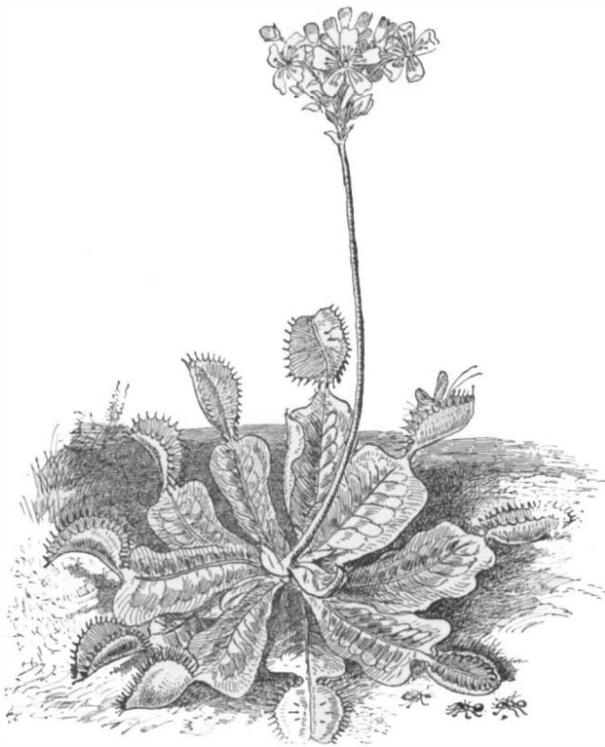

DIONEAE MUSCIPULA.

the place of these innutritious substances, and you shall see the tentacular glands gradually bend over, and assisted by the curling up of the leaf itself, and by the curling up of the leaf itself, enfold the esculent morsel, and cover it with a digestive fluid, which at once dissolves it and adapts it to be assimilated by the insect-eating plant. But it is worthy of note that the instinct of the plant, under certain exceptional circumstances, like the instincts of insects, sometimes goes wrong; for the sundew as eagerly accepts morsels of cheese as it does of any other nitrogenous substance, and cheese is a poison to the *Drosera* plant. The sundew is not the only plant which exercises choice and discrimination in the selection of its food. In and about the swamps of North Carolina, and indeed in many other parts of the United States, is found the *Dionaea*, or Venus' fly-trap. It has, as has the *Drosera*, very small roots, which, like those belonging to the sundew, serve only to give it a foothold, and supply it with moisture; the plant captures the food necessary to its subsistence. The leaf blade is constructed like a steel trap, the two halves snapping together, and the marginal teeth interlocking as do the teeth of a trap. Long, sensitive bristles, generally three in number, arranged in a triangular order, erect themselves upon the upper surface of the trap. Touched ever so slightly by a hovering or flying insect, they transmit an impulse which in an animal would be called a mandate of its will, to the muscles or the machinery that moves the lobes of the trap, and so instantly is this obeyed, that these lobes close upon the insect and capture it. Inorganic bodies placed upon the lobes, unless they touch the sensitive filaments, do not cause them to close; organic bodies when moistened and placed upon the leaf, cause it, after absorption has begun to take place, to close slowly. The lobes may be made to close over either organic or inorganic substances, but with a difference. When an inorganic substance is placed upon the leaf, and one of the sensitive bristles is touched, the leaf indeed shuts up, but in such a manner as to leave a hollow space between the lobes of the trap; it is as if the plant were tasting the substance to see if it were fit for food. When, on the other hand, an organic substance falls upon the leaf, both lobes press against it and against each other with force enough to flatten out a portion of the white of a hard-boiled egg, that they have been made to close upon. Again, when any innutritious substance is caught, the glands are not excited to secrete the digestive fluid, and the lobes soon open, freeing the substance and showing it perfectly dry. If the object caught is too small to make it worth the attention of the plant, it is allowed to escape between the interlocking teeth; but if the quarry be large enough, and of a nutritious character, the lobes will remain flattened together over it for fifteen, twenty-four, or even thirty-five days.

Darwin, speaking of the sensitiveness of root tips, shows that they have developed diverse kinds of sensitiveness, so that "it is," he says, "hardly an exaggeration to say that the tips of the radicle thus endowed, and having the power of directing the movement of the adjoining parts, act like the brain of our lower animals, the brain being seated within the anterior end of the body, and directing the several movements."

The wonderful power of this substitute for a brain, as shown in its leading the parts to which it is attached over, under, or around every intervening obstacle through the dark earth to a more or less distant water supply, or a rich deposit of nitrogenous nutriment in the form of a buried carcass, is it not quite as wonderful as the faculty of the bee in finding its way to its nest, or of a male moth discovering from a great distance the locality where a female of the same species is hidden?

Of course only the merest glimpse at the wonderful reflex action of plants can be here given, but a more extensive investigation of the subject leaves the student impressed with the fact that both plants and insects develop along narrow lines a perfection of power in adapting means to an end that nothing in the plant or in the insect can at all account for, and that as students of Nature are beginning to believe, no series of merely fortuitous, aggregated variations can explain.

As the construction of the Nile reservoir at Assouan involves the unavoidable submersion of a portion of the temple of Philæ, situated upon the island of Philæ, the Egyptian government has decided to take all possible steps to preserve a record of these monuments as they existed prior to the rise in the water levels, and also to lessen any danger which might arise from the annual inundation. The record of these historic monuments has been completed, and now to insure the stability of the structures the foundations of the temples are being underpinned. As the foundations of the temple of Isis were found to descend everywhere to the solid rock, it was decided to limit the operations to the consolidation of the other structures. It is expected that the work will be entirely completed in the course of a few weeks.

#### MIXING PUMP.

The blending of whisky and the rectification of spirits in general is based on the fact that cheaper qualities can be improved considerably by the addition of comparatively small quantities of higher grade goods, certain essential oils, and other ingredients. To effect such an amelioration, it is a matter of the utmost importance that all constituent parts are not only poured together, but that the mixture is thoroughly stirred and repeatedly agitated, that all particles may mingle freely and every ingredient become distributed most minutely. Only by infinite diffusion and energetic agitation can the different parts of the mixture act upon each other chemically, and effect

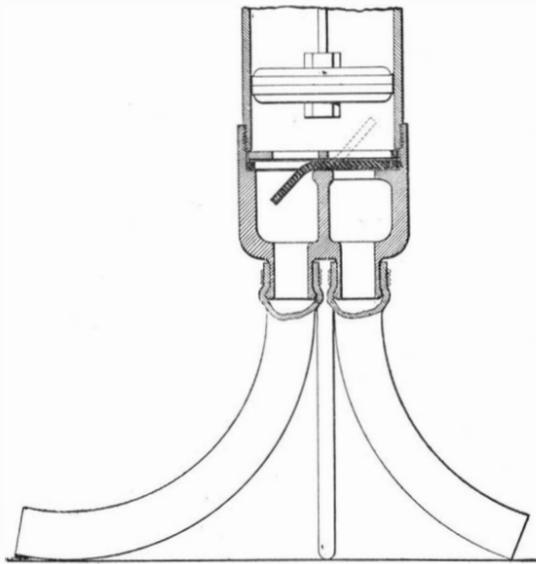

DIAGRAM OF THE MIXING PUMP.

a blend of uniform character that bears the savor of "age," otherwise obtained only as the result of years of careful storage and maturation. This vital point of stirring up and agitating the mixture is too frequently neglected, especially in smaller establishments with limited storage facilities, where ingredients are added to liquor already within the barrels. The shaking of the barrel or package is certainly insufficient to mix the heavy sirup and other sweetening matter with the light spirits, particularly in moderate temperatures. Nor can the oils be properly diffused by the mere rolling of the barrels or stirring with a stick through the narrow bunghole. Stirring in open tanks has the great disadvantage of reducing the strength in alcohol and aroma, by continually exposing new parts of volatile matter to the air. Under certain conditions this renders liquor cloudy through



MIXING PUMP IN OPERATION.

the oxidation of essential oils exposed in this manner. To achieve the best possible results it is necessary that the stirring be done most energetically near the bottom of the vessel, where sirup and other heavy matter will settle; that part of the mixture be forced into the rest with a certain pressure, thus creating a strong current and numerous whirls throughout the tank or barrel; and that the air be excluded as much as possible.

A simple and effective tool, that complies with all these requirements, is a mixing pump just patented by Mr. Herman Soellner, of 842 Bushwick Avenue, Brooklyn, N. Y. One of our views shows the pump in operation, while the construction is clearly indicated in the diagram. The plunger fits snugly in a cylinder, at the bottom of which is a double nozzle

controlled by a double valve. Connected to the nozzles are two sections of rubber hose, while a metal spur in the center serves to hold the pump in proper operative position. Now, when the plunger is drawn upward the rubber valve-disk is sucked up, closing the left-hand nozzle, but opening the nozzle at the right, as indicated by dotted lines. The cylinder will thus be filled with the liquid, which on the downward stroke is discharged through the left-hand nozzle. Repetition of this process results in establishing a current through the liquor, which thoroughly mixes all the elements. The discharge pipe, it will be noticed, is longer than the receiver. The purpose of the former is to direct the current in a whirl that embraces the entire contents of the barrel, while the latter pipe receives its supply from the bottom, where the heavier matter is most apt to settle. From a practical point of view this tool fills every want. It can be used in a tank as well as in a barrel of any size. Its simplicity, lightness and easy manipulation appeal to the workman, who can assume a comfortable position, slip the mixer through the narrow bunghole and achieve all that is required within a few seconds. All parts of the mixer are interchangeable, indifferent to alcoholic solutions of any strength and need no cleaning other than rinsing to remove the characteristic flavor of the respective liquors. The utility of this mixing pump is not limited to the rectification business only, as it will mix fluids of the most different chemical nature and specific gravity. It causes a perfect solution and disintegration of salts, oils, chemicals, paints, etc., and also distributes insoluble matter, such as charcoal, boneblack, and other materials.

#### French Competition for Belt Mounters.

The numerous accidents to workmen in establishments where belts are used has recently brought about the stringent application of a French law, forbidding the removing or replacing of a strap by hand while the machinery is in motion.

In order to obviate the waste of time consequent upon the stopping of the machinery, an association of French manufacturers has announced an open international competition for the best fixed belt mounter.

The invention should be designed for simple and not for conical pulleys, and must comply with the following conditions:

- (1) It must be simple, strong, and occupy little space; easy to fix and use.
- (2) Not dangerous in working.
- (3) Convenient for any speed, width, or position of belt.
- (4) Able to throw the belt off or on.
- (5) Sufficiently low in price to allow of its wide use.

Competitors are invited to send a full description of their invention, accompanied, if possible, by a model or at least by satisfactory illustrations, to the president de l'Association des Industries de France contre les Accidents du Travail, No. 3 rue Lutèce, Paris, prior to October 1, 1902.

This notice may be of interest to American inventors or to firms dealing in machinery of this character.

#### The Current Supplement.

The first article in the current SUPPLEMENT, No. 1381, is a well-illustrated account of rice culture in the United States, by Dr. S. A. Knapp. Of technological interest is an illustrated description of the mechanical manufacture of bottles. A new army pistol used in Switzerland, and called the "Parabellum," is made the subject of an article, accompanied by several engravings. An entertaining essay by Frank Hix Fayant tells how electrical engineers are trained. William A. Del Mar, who has contributed to the SUPPLEMENT many articles of practical interest, describes graphically how a modern coherer is made, and tells something of its history as well. The use of oxygen in cases of carbon monoxide poisoning may be of value to physicians. H. M. Miller pictures the manners and customs of the people of Southern Borneo. A very full treatise on carbureters will interest some of our automobile readers. The Consular Notes and Selected Formulæ will be found in their usual places.

#### International Navigation Congress.

From June 29 to July 5, 1902, the Ninth International Navigation Congress will be held at Düsseldorf. The aim of the Congress is the encouragement, promotion and improvement of navigation, as well as the exchange of experiences gained. Technical and economical questions relating to inland and ocean navigation will be discussed.

Oscar McClellan, a printer, inventor and bosom friend of Edgar Allan Poe, died at his home in Philadelphia recently at the age of 82 years. He was an inventor of some note, and three times had placed himself in an independent position through his inventive genius. His last achievement in this line was an improvement on a machine for performing some of the operations of shoe-making, for which improvement he received \$80,000 in royalties.

**THE RUINS OF ST. PIERRE.**

We are enabled to give our readers, in the present issue, illustrations of the ruins of St. Pierre, that quaint, old-fashioned town which but yesterday was the most picturesque spot in the West Indies. Though the first news of the tragedy filled us with horror, our minds were unable to picture the awful extent of the disaster which we are now only just beginning to appreciate. One of our illustrations gives us a general view of the city, showing the bare ruins, the broken walls, the blackened tree trunks, the wreck of years of labor—a grim picture of death. St. Pierre owes the completeness of its destruction, in a great measure, to the manner in which its streets were laid out. The city rises in terraces parallel to the water-front. The streets, twisted and curved, run mainly in the direction of these terraces. There are few cross streets, only three or four leading down to the water's edge. Thus it was that when the eruption came, all the walls parallel to the sea-front and directly opposed to the volcanic blast were immediately leveled, burying the frantic pedestrians, choking up the long, narrow passageways, and destroying all avenues of escape.

The cathedral, whose ruins appear in several of our views, was a handsome piece of architecture. In its belfry hung the finest peal of bells in the West Indies. It commanded a fine view of the sea, and was a most conspicuous object in the panorama of the city. On the eventful morning of the disaster the church was crowded, for it was the day of the Feast of the Ascension. No human work could withstand the fury of that blast. The great structure, the pride of St. Pierre, lived but a moment, and then fell, obliterating those who had put faith in its massive walls and strong roof. The great bell of the cathedral may be seen in one of the illustrations, partly buried under the refuse.

A very interesting part of the ruins is the burying place of the city. Every headstone is destroyed, and all signs of graves are effaced. One of the illustrations shows the vaults with their little mortuary chapels. Wreaths and mortuary emblems; handsome silver lamps and candlesticks may be seen in these tiny chambers.

Everywhere is destruction. Substantial residences and beautiful gardens all shared the same fate, and over all lies a white pall of ashes.

According to Prof. R. T. Hill, of the National Geographical Society, the area of the catastrophe forms an elongated oval, covering eight miles of land, in which there are several well-marked zones; the first or center zone, in which all animal and vegetable life is utterly destroyed; the second, in which a blistering flame killed animal life and burned the leaves on the trees, but did not entirely destroy the leaves themselves; and the third, a zone of ashes which did slight damage to vegetation only. The northern portion of St. Pierre was in the first zone, and here all animal and vegetable life was instantly annihilated. The terrible explosion of gases must have had tremendous force, for guns in a battery on a hill south of the city were dismantled and carried for yards.

A new crater midway between the peak of Mont Pelée and the sea was the cause of the destruction of St. Pierre, and is still vomiting forth black mud, while sympathetic and synchronous eruptions are taking place in the old crater.

**Baldwin Relief Party.**

News comes from London that W. S. Champ, secretary of the Baldwin-Ziegler expedition, has started on his journey to search for Evelyn B. Baldwin, who is now in the polar regions. Mr. Champ will leave Tromsø in July, and will first endeavor to find the "America," which is believed to have wintered in latitude 82 degrees north. Mr. Champ expects to return between October 1 and 15.

**The Longest Railroad Run on Record.**

The Pennsylvania Railroad has had a run made from Pittsburg to New York, 438 miles, without a stop. This is the longest run of a passenger train on record. In order to accomplish this feat it was necessary for the locomotive to carry an extra supply of coal, and this was done by enlarging the locomotive tender.

**Correspondence.**

**Volcanoes and the Sun and Moon.**

To the Editor of the SCIENTIFIC AMERICAN:

Kindly permit me to call your attention to some remarkable coincidences between certain positions of the moon, relative to the earth and sun, and the recent earthquakes and volcanic disturbances. Do not the following comparisons of facts go to prove that such disturbances are most likely to take place when the moon is directly in line with the earth and sun (conjunction, opposition, eclipse), when the moon is nearest the earth (perigee), and when it crosses the earth's equator?

The moon crossed the earth's equator on April 19; the terrible earthquakes in Guatemala began on the evening before and continued until the 21st. The moon was full and at eclipse node on April 22; the volcanoes in the West Indies first showed signs of activity on the day following. The moon crossed the equator again on May 3—the day that Mont Pelee, on the island of Martinique, first began eruption. The moon was new and at eclipse node on May 7 and in perigee on the 8th; La Soufrière volcano, on the island of St. Vincent, began violent eruption on May 7, and Mont Pelée destroyed the city of St. Pierre on the 8th. Then, as the moon receded from perigee, getting farther away from the earth, the volcanoes gradually quieted down until the activity ceased on May 15. The moon crossed the equator again on Friday evening, May 16, and on Friday Mont Pelée again began eruption, which became violent next day.

The writer has for several years been observing this

carefully investigated by scientists for the benefit of mankind.

ELMER G. STILL.

Livermore, Cal., May 18, 1902.

[We have but little faith in the influence of the variation of the tidal action of the moon, sun, and planets on the seismic perturbation of the earth's crust. To establish any relation of tidal and seismic action, a reference must be made of these conditions at moments of volcanic outbreaks or severe earthquakes in long periods past. The tidal force of the moon is at its maximum every lunar day in some part of a zone of the moon's declination north or south, intensified only by the sun's tidal value at conjunction. Its effect on the tidal pressure of the oceans is varied by the contour of the continents and is probably larger where earthquakes are least felt and not in the regions of volcanic activity; for instance, the tides in the Antilles are only two feet at spring, and are equally small in the regions of great volcanic activity in the past—Krakatoa, Vesuvius, Japan, Central America, Iceland, Mount St. Elias—while the region of greatest tidal force, the Bay of Fundy, is comparatively free from seismic disturbance.

We rather attribute earthquakes and volcanic disturbance to the strain and pressure caused by the contraction of the earth's crust upon heated matter in the interior of the earth and its consequent outbreak at the weak points, which are represented by the relief vents that have been in action for thousands or perhaps millions of years.—Ed.]

**A Trip on the "Fulton."**

To the Editor of the SCIENTIFIC AMERICAN:

Perhaps you will consider the following extract,

which I have just come across, in the diary of Rev. G. Washington Phillips, written in 1817, of interest to your readers as bearing on the series of papers which has lately appeared in your newspaper:

"In the evening I proceeded to the steamboat, with the intention of taking a passage to New York. Seldom have I been more entertained than at the surprise and admiration expressed by the African servants we had brought over. They had heard of ships without sails, impelled by fire, but had always considered such reports as altogether fabulous. When, therefore, they beheld the steamboat, like a huge sea monster, floating on the surface of the water, advancing with inconceivable rapidity amid the foaming billows; heard the clatter of the water wheels, the hollow sound of the machinery working,

and the sudden crash caused by the discharge of steam through the valves, they were completely aghast. Some persuasion and encouragement were necessary to make them venture on board. The vessel, which was named the 'Fulton,' was near 156 feet in length, with excellent accommodations of all sorts. At 8 o'clock the following morning I found myself at New York, distant a hundred miles, without any of the fatigue, delay, or inconvenience of a land journey or any of the uncertainty and risk of water carriage."

He then gives an interesting description of New York, which "like ancient Tyre, rises amidst the waters and presents a very magnificent spectacle as it stands surrounded with a forest of masts." What would he say to the New York of 1902?

A. E. MURRAY.

About thirty million gallons of mixed paint were sold in the United States during 1901. The greater portion of this was not used in the large cities, but in the towns and villages, where structures are of wood. In no country is so much paint made as in the United States of America, and the bulk of that paint is composed of lead, zinc, and linseed oil, and only the darker shades are made of oxides of iron and other pigments. Many manufacturers use a small quantity of water in their mixtures, and when the quantity of water is not over 2 per cent, it cannot be regarded as an adulterant. The water used is usually slightly alkaline, and in the case of lime water it forms a calcium soap with linseed oil and thickens the paint, so that it never settles hard in the tin and is easily stirred.



Photograph by C. L. King.

**ANOTHER VIEW OF THE RUINED CATHEDRAL.**

relation between the positions of the heavenly bodies and seismic, volcanic, and electrical disturbances, and is forced to the conclusion that the latter are caused in part by the conjunctions, oppositions, perihelions (or perigees) and equinoxes of the moon, earth, and seven other planets, especially when several of these occur at once. Such disturbances do not always occur at these times, but observation proves that nearly all of them do so occur. It is not claimed that the relative position of the heavenly bodies is the sole cause; it is only an aggravating cause and must be combined with local causes and conditions in order to produce seismic and volcanic disturbances. Scientists now recognize the fact that sun spots are caused by the perihelion, etc., of Jupiter and other large planets. Then why are not earthquakes caused in the same general manner?

The writer is convinced that severe disturbances of these kinds can be predicted as accurately as the weather, and that the recent volcanic outbreak could have been predicted with a certainty several days in advance, and the awful loss of life thus averted. The writer felt certain that there would be another severe volcanic eruption on May 16 and 17, and it came.

The moon will cross the earth's equator again on May 31 and June 13, will be in perigee on June 5 and new on June 6; therefore, more volcanic and seismic disturbances are probable on and about those dates in various parts of the world, but especially where they have been occurring recently.

I submit these facts and theories for your candid and unbiased consideration, and in conclusion I earnestly request that you express your opinion of them in the SCIENTIFIC AMERICAN, or at least explain them to your readers, so that these facts and theories may be

**EXTRAORDINARY TRENCH DIGGING.**

BY GEORGE J. JONES.

A notable piece of excavating machinery is to be seen working at present just outside of Moorestown, N. J., where a sewer system is being laid. The machine referred to is a trench digger, which, operated by five men, cuts a swath through the earth with marvelous rapidity and neatness. The operation of this machine represents a saving as compared with hand work in many different ways. In the first place, in order to lay the smaller sizes of pipe, it is necessary to dig a hole very much larger than is required for the pipe in order to accommodate the bodies of the men who must work in the trench. Then again, where the pipe is to be planted at some considerable depth, the men are compelled to work in stages, and the soil removed must be handled many times before it is finally passed out of the trench. When this trench-digging machine is used, the hole is made just large enough to accommodate the pipe, and this represents a great economy in the amount of material handled. This machine is built by the F. C. Austin Manufacturing Company, of Harvey, Ill., to whom we are indebted for much of the information found herewith, but the photographs were specially made for this article. The machine at work at Moorestown is the largest and most powerful ever built by the company.

The digging machine is built of a framework of I-beams mounted on four broad-tire wheels, and in front of it as it cuts its way along through the earth is a 25 horse power traction engine which supplies the power, the connection being made through a chain belt.

At the other end of the machine there is a twenty-foot shaft of light iron work, the free end of which has a vertical movement. A pair of sprocket wheels at each end carry an endless link belt built up of steel drop-forged links and connected by cross-bars and flat blades or scrapers. Fastened to each cross bar are two plow-shaped cutters, the latter being staggered, so that the whole series of cutters will cover the whole width of the excavation. Alternate bars are fitted with side cutters for trimming the sides of the ditch. The dirt is carried to the top and deposited on a rubber belt, which carries it to either side as may be desired.

The buckets, immediately behind the cutters, are themselves of peculiar design, as they open automatically when they reach the end of the shaft nearest the hopper, and thus prevent any of the excavated soil from remaining in them.

The chain with

its buckets and cutters passes over the main shaft of the machine, and the other end is lowered into the ground and does the cutting. Its position is capable of constant and instant adjustment, so that a ditch of six inches can be dug as readily as one of twelve feet. This hoisting or lowering to the required depth is accomplished by means of a steam gear, which

crowds the rack at the rear of the machine either down or up as the case may require. It will be seen that the weight of the machine is thus applied to the crowding device, is removed entirely from the banks of the ditch, and instead assists in the cutting, as the pressure is applied to the breast of the cut.

An iron stake is anchored some eight or nine hundred feet in advance of the machine, to which a cable is attached, this being spooled on a drum in the front part of the machine. At every revolution of the gear wheel a certain amount of this cable is wound up by means of a ratchet device, and gives a steady advance which is automatic. This is capable of regulation, and the speed with which the digger passes along through the earth may be adjusted to the varying conditions of the soil encountered.

The work at Moorestown was hampered to a very large degree by the presence of quicksands, which were not anticipated. The buckets used are not adapted to raising this character of material, but small rocks and frozen ground are easily handled by the machine. This machine with its crew of five men does work which would be a credit to a very large force of laborers. Under favorable circumstances a ditch four feet deep can be dug at the rate of sixty feet an hour.

For the purpose of preventing street accidents during fogs, which are frequent in London, at certain periods of the year, the Westminster County Council has devised a convenient portable apparatus of great illuminating power. The apparatus consists of a round tank 24 inches high by 18 inches in diameter, charged with 25 gallons of petroleum. By means of compressed air the oil vapor is forced from the tank into a standpipe, attached to which is a burner. By means of a little naphtha, benzoline or paraffin, with which the burner is saturated, the means of igniting the vapor are obtained, and a powerful torch is produced with a flare ranging from 18 inches to 2 feet and a power equal to upward of 1,000 candles. A number of these "fog lights" are maintained ready for use night and day at various depots, and the attendants, who are trained in the management of the apparatus, wheel it to any desired point when the necessity arises.

The German government has purchased the patent rights covering all Europe except Great Britain, Ireland, and France, for an automatic switchboard manufactured in Chicago. The electrical appliance will displace a telephone system of 40,000 instruments.

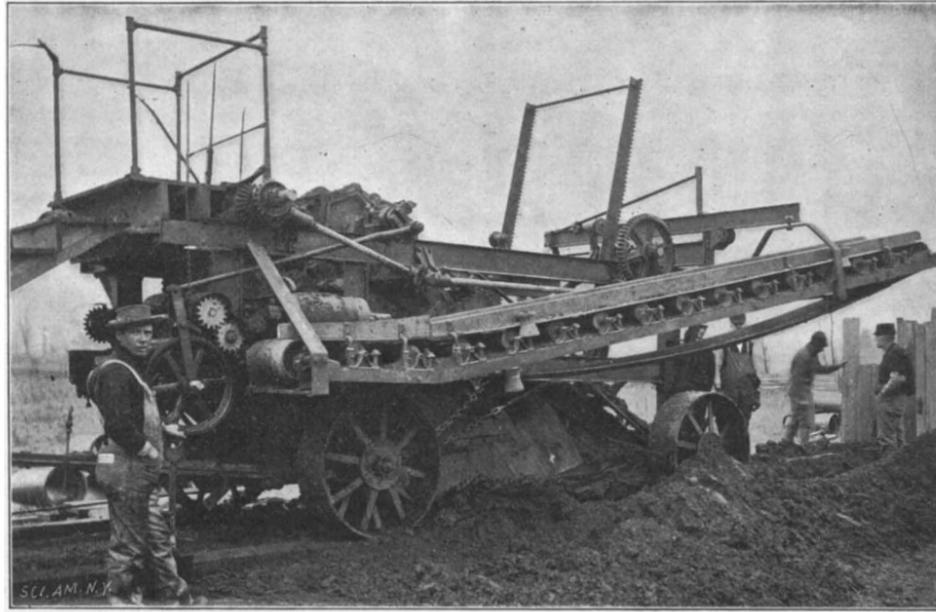

**TRENCH DIGGER, SHOWING CONVEYER FOR DELIVERING THE SOIL AT THE SIDE OF THE DITCH.**

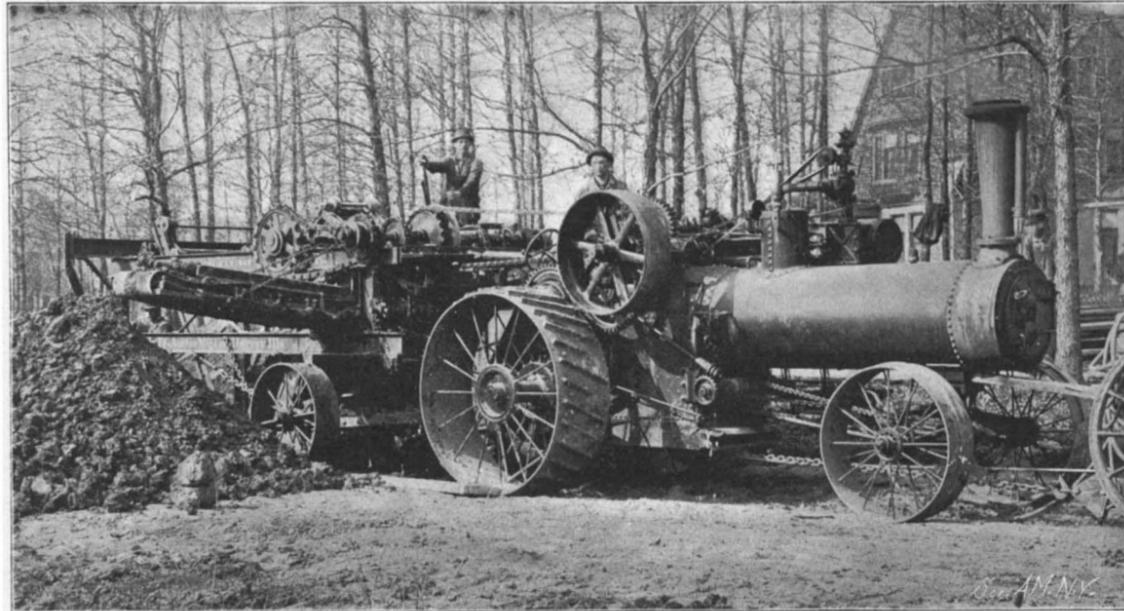

**THE TRENCH DIGGER AND ITS ENGINE.**



**A VIEW SHOWING ENDLESS CHAIN WITH BUCKETS.**

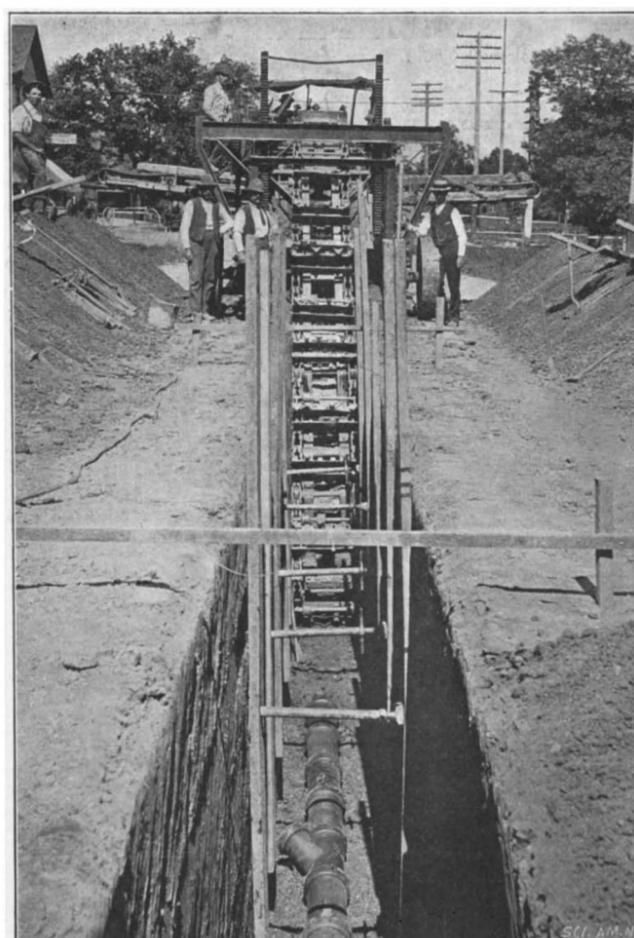

**A DEEP TRENCH DUG BY THE MACHINE.**

**A 20-TON TRAVELING ELECTRIC CRANE.**

We reproduce herewith a photograph of a 20-ton traveling electric crane, which has been designed, built, and erected by Messrs. George Russell & Co., shipbuilders and engineers of Motherwell, Glasgow, for placing on board vessels the lighter portions of machines, etc. The working load is 20 tons, lifted at a radius of 42 feet 6 inches, and 15 tons at 50 feet radius. The derricking gear varies the radius from 25 to 60 feet. When at 42 feet 6 inches the height of the jib pulley is 62 feet above the wharf. The lifting hook has a vertical range of 84 feet. The carriage is mounted upon eight wheels, with two at each corner, and has compensation balance levers to equally distribute the weight. The gage is 23 feet center to center. The 20-ton load is lifted at 25 feet per minute, and slewed at 150 feet per minute. The crane travels along the wharf at 60 feet per minute. The electric motors, of which there are three, were supplied by British Thomson-Houston Company. One 48 horse power for hoisting and derricking; one 12 horse power for slewing; and one, also 12 horse power, for propelling the crane along the wharf; all the movements and gearing are independent of each other.

The crane is supplied with power by means of a flexible cable, fed from junction boxes placed at intervals along the wharf. The cables pass through the center of the post, from which the current is taken to the rotating part. Four slip rings are also provided for transmitting the current to the traveling motor, which, with the others, is controlled from the craneman's house.

**News of Goubet's Submarine.**

As M. Goubet, the inventor of the submarine boat which bears his name, has failed to dispose of his craft to the French government, he has sold the two boats already constructed by him, and all of his inventions relating to submarine navigation, to an English syndicate, which is going to establish yards upon the Thames for the construction of vessels of this

type. The inventor, together with his son and an expert engineering assistant, have also disposed of their services to the new company.

M. Goubet has devoted several years research to the perfection of his vessel, and has made repeated overtures to the French Admiralty to purchase the invention for utilization in the navy. The first vessel the French government refused because it was not sufficiently large to carry the Whitehead torpedo.

The inventor thereupon set to work upon a second vessel, of such dimensions as to meet all the requirements of the French Naval Department. Before, however, he had completed the "Goubet No. 2," the French government had decided that the sub-

marine vessels to be adopted for their navy were the "Gustave Zédé" and "Gymnote" types. M. Goubet immediately repeated his representations to the French government, but the authorities turned a deaf ear to his requests. At this juncture a syndicate was formed in London to purchase M. Goubet's idea, lock, stock and barrel, and the inventor closed with the offer. The syndicate comprises several naval experts of the English navy, and the price paid to M. Goubet was \$20,000 down, and a third share of the profits.

Already orders have been secured by the new syndicate for the construction of a number of vessels for one leading European nation, and a South American State. The British Admiralty also instructed their ex-

The latest Goubet design carries two Whitehead torpedoes, and has accommodation for a crew of three men. Another recommendation in its favor is its small cost. A Goubet boat can be built for \$30,000, as compared with \$150,000, the price of a Holland boat. It is propelled by electricity, rises and sinks upon an even keel, and can remain submerged for eight hours.

For naval purposes the Goubet boat is intended essentially as an auxiliary to big warships, being carried on board, and in action, dropped over the side by means of a crane or davit. It is also peculiarly adapted from its small dimensions for purposes of coast and harbor defense with great effect, and in river work for destroying bridges.

Among the most interesting trials to which the "Goubet" has been subjected was a series of experiments at Cherbourg. The submarine maneuvered for two and a half hours under water absolutely unnoticed, during which time it recovered the anchors of a number of buoys, setting them at liberty, cut the moorings of other buoys and boats, discharged blank torpedoes, affixed sham explosives to vessels at anchor and in motion, and then rose to the surface with its crew as little affected by their experience as though they had been above water all the time.

The English company which has acquired the patents are building a new boat of the newest design to be called the "Goubet No. 3," which will be exhibited to the officials of the British and foreign governments.

Following another recent wreck upon the Manacle Rocks off Falmouth in the south of England — where the "Paris" and "Mohegan" were stranded — and petitions from the Falmouth Chamber of Commerce, the British Board of Trade and the Trinity House have arranged to place a gas-lighted buoy at the Manacles, in place of the existing bell buoy. Since the wreck of the "Paris" the local authorities have spared no effort to have a lighthouse built upon the spot, but the Trinity

Brethren refuse to accede to any such proposition, claiming that such a lighthouse is unnecessary and would prove confusing, as this part of the Channel is already freely lighted.

**A New Cooling Machine.**

Prof. Willis L. Moore, Chief of the United States Weather Bureau, has invented a cooling machine which is intended to reduce the temperature of buildings in hot weather. The machine is said to have a capacity for cooling about 20,000 cubic feet of space during the hottest weather. The fact that foreign patents are still to be obtained renders it difficult to obtain full particulars of the invention.

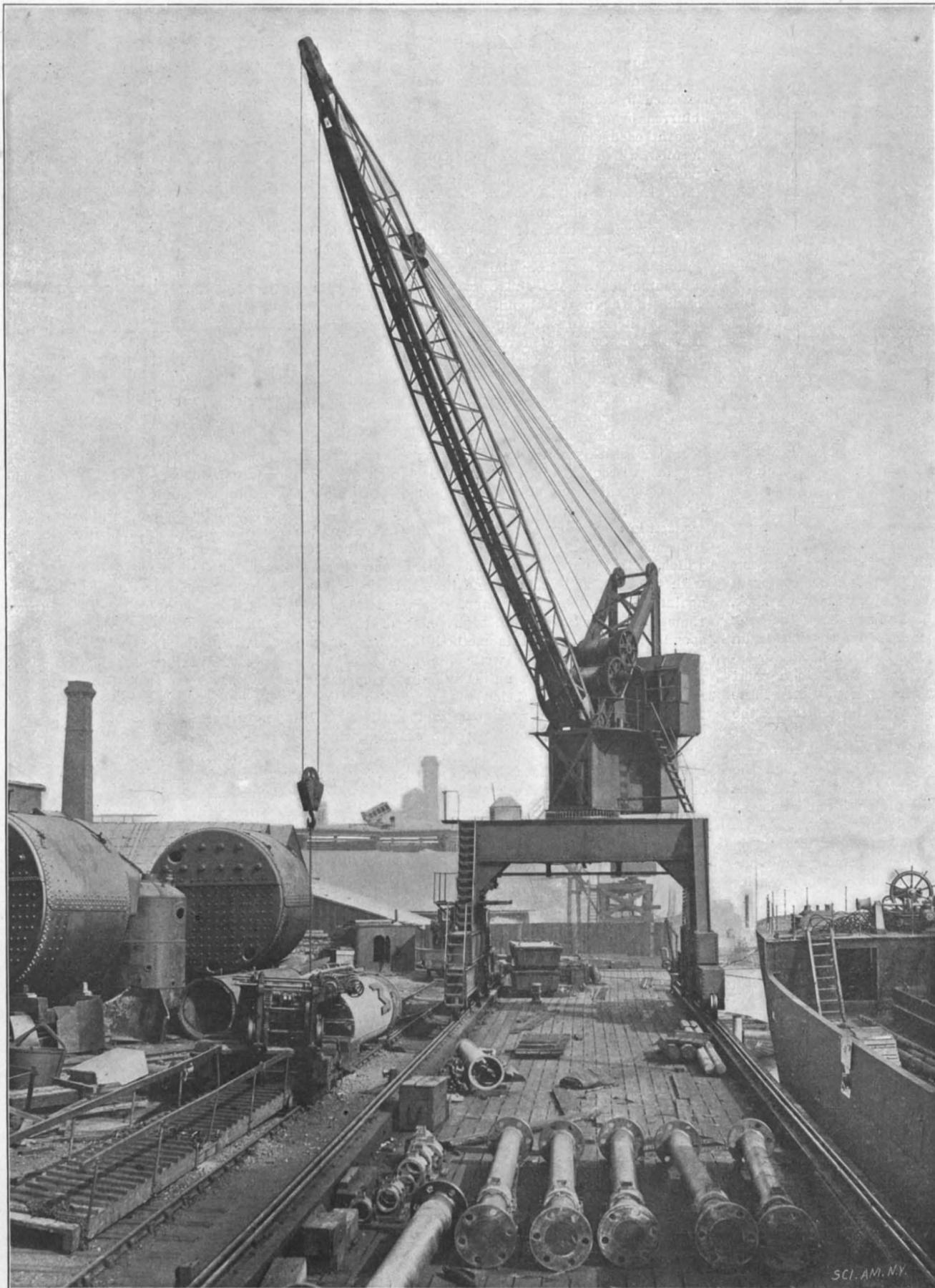

**TWENTY-TON ELECTRIC CRANE AT WALLSEND-ON-TYNE.**

perts to investigate the claims of the Goubet vessel, and as the report upon the subject is favorable a number of boats are to be ordered for the British navy. One clause of the agreement stipulates that in the event of the French government's deciding upon any Goubet boats, the vessels shall be built in France, and already negotiations have been completed with a French shipbuilding firm for the completion of any such orders emanating from the French Naval Department.

The most salient characteristics of the Goubet boat as compared with other submarine types are its lightness and small dimensions. As a matter of fact it is really portable, for it only weighs 11 tons complete.

**THE ELLIOTT BOOK-TYPEWRITER.**

As soon as the ordinary typewriter came into general use and proved indispensable for letter-writing, it was only a question of time when a machine would be built which could be successfully used for typewriting in books. It was not long before a typewriter meeting these requirements was put on the market, and its widespread popularity proves its efficiency. The machine has opened up a new field and does all that can be done by an ordinary machine, as well as work that cannot be accomplished without its means. It will write on books of any size and shape, and is desirable for record books, sale books and the like. Its name, the Elliott Book-Typewriter is, however, misleading, for aside from its value in book work, it will do also, and just as quickly, all the work that the or-

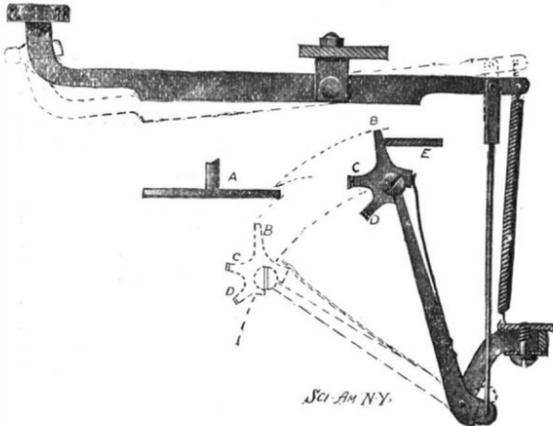

Fig. 2.—THE "SHIFT" MECHANISM.

inary typewriter does. Its value in manifolding is particularly worthy of notice. The sheets are laid on a flat platen and the type bars strike downward, giving a firm, heavy blow, producing as many as twenty legible copies. It is equipped also with a tabulating device which automatically locates the column and the decimal point in the column.

A table is provided for use with the machine, which table, while not in any sense essential to the proper working of the typewriter, is nevertheless a great convenience for writing in books. Two spring-platforms are mounted to travel lengthwise along the center of the table, and are adapted to support the open book, bringing it to a proper level. The weight of the book adjusts these platforms automatically, so that if an entry is to be made in the front of the book, for instance, the right-hand platform depresses to a point which levels the thick with the thin portion of the book. Before placing the book on the platforms the machine is raised to a vertical position on hinges at the rear, thus giving access to the table. The platen is now brought down and the page upon which the writing is to be done is brought over onto it. Then the machine is lowered and the platen frame holds the paper securely in place and ready for the writing.

The book-typewriter differs from others in this respect, namely that the paper is stationary and the whole writing mechanism or carriage moves over its surface, traveling on rollers at the front and rear. The rear rollers are in pairs, oppositely disposed on the carriage guide-rod and have concave peripheries adapted to fit the surface. Width of margin is regulated by collar-stops on this guide-rod which limit the lateral motion of the carriage. A bell is secured to the right collar-stop, and is rung automatically at the end of every line. The carriage is fed laterally under tension of the band spring by a ratchet escapement mechanism which permits the intermittent rotation of a gear wheel traveling along the rack on the guide rod. This escapement is of course operated by the finger and space keys. The whole escapement mechanism is pivoted to swing upward when the release-lever is operated, thus disengaging the escapement-gear from the rack and permitting free lateral movement of the carriage. As soon as the line is completed the entire machine is fed forward on the platen-frame by pressing together the two levers on the right. The width of space can be regulated by shifting a small thumb-screw just above the rear spacing lever. If desired the front spacing lever may be locked out of engagement with the rack on the platen frame, permitting the machine to be moved rapidly to any desired spacing.

The type-bars of this machine are one-third shorter than the standard typewriter and, therefore, permit

a much shorter key-stroke, and consequently a much higher writing speed. The universal keyboard is used. The type-bars are arranged in a circle and are each provided with a type-head having two types, either of which can be operated by striking a single key. Our second illustration shows the ingenious device by which the capital character situated at *D* may be brought into the printing position instead of the lower case character situated at *C*. A disk, *A*, is situated in the center of the type-bar circle, and when the "Caps" key, at the left of the keyboard, is depressed, this disk is lowered sufficiently to engage the arm, *B*, on the type-head, thus rotating it and bringing the character at *D* into the writing position. A flat spring rests against the type-head and holds it securely in either of its two positions. On the return of the type-bar the arm, *B*, strikes a ring, *E*, which returns the type-head to its normal position. Means are also provided for locking the spacing disk in its lower position.

The indelible ribbon used in this machine is unaffected by acids or climatic influences and cannot be blurred by a wet cloth. It is wound on two spools, one at each side of the carriage and is fed through a fork which holds down the paper at the writing point. This fork may be operated by depressing a lever back of the keyboard, to raise the ribbon and expose the writing to view.

A very important feature of this machine is the tabulating attachment which permits the operator to jump the carriage from the last character written on a column to the exact place where the writing is to begin in the next column. A scale runs along the back of the machine and its graduations correspond to those of a scale which rests against the paper. An indicator on the upper scale points always to the point which will be occupied by the next letter struck. On this upper scale is a set of tabulator stops which can easily be snapped on or off. These may be located according to the position and number of columns desired, which is quickly done by comparing the two scales. Just above the keyboard are located eight keys which are employed in jumping the carriage from column to column. Now, if, for instance, the number to be written in a column be expressed in five figures, or ten thousands, the fifth key from the left is depressed, which lifts the escapement mechanism out of mesh with the rack and at the same time presents a lever against the next tabulator stop, which halts the carriage five spaces from the right edge of the corresponding column. By this method the operator can speedily and unerringly write his figures in their proper positions so that units will always appear directly below units, tens below tens, etc. The value of this attachment is very apparent to railroads, insurance companies and others whose work largely consists of figures and tabulated work. The machine is built by the Elliott-Hatch Book-Typewriter Company, of 256 Broadway, New York city.

**A New Ocean Record.**

By the narrow margin of 0.02 of a knot the hourly speed record for the Atlantic Ocean, held by the Hamburg-American liner "Deutschland," was broken by the

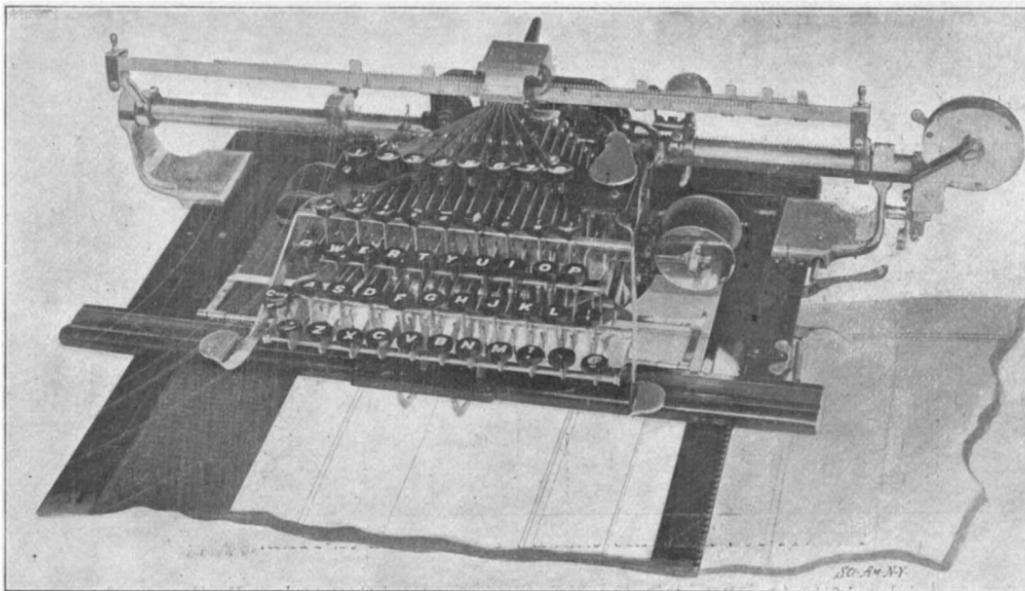

Fig. 1.—THE ELLIOTT-HATCH TYPEWRITER.

"Kronprinz Wilhelm." On this record-breaking trip, the "Kronprinz Wilhelm" covered the distance of 3,095 miles from New York to Plymouth in 5 days 11 hours and 32 minutes, at an average hourly speed of 25.53 knots. Her daily runs were 434, 550, 535, 534, 552 and 490 miles. This is the best eastward record for speed thus far made across the Atlantic.

The torpedo boat "Wilkes" completed her trial trip off Newport, R. I., June 6, and over the measured mile course made a speed of over 26 knots.

**A NEW FORM OF TRUNK.**

Now that the summer season is at hand, and our visions of mountain and ocean scenery or a quiet vacation in the country are about to be realized, it is time for us to come down to the irksome details of preparation for the trip. The packing of a trunk is always a nuisance, and unless one does the work systematically, considerable annoyance will be experienced. Articles not desired on the trip must be packed at the bottom of the trunk, and those that will be in immediate demand should occupy convenient places at the top. But even with the most careful planning one is apt to want in a great hurry some article packed at the bottom of the trunk, and before long confusion and disorder prevail, resulting in ruffled and

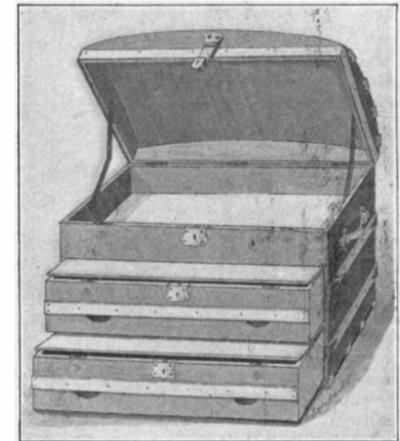

COMBINATION BUREAU AND TRUNK.

wrinkled clothing. Those who have experienced these troubles will take a great interest in the trunk here illustrated, which is the invention of Mr. Braine Walsh, of Lansingburg, N. Y. This trunk is essentially a chest of drawers so constructed and braced as to withstand the wear and tear of transportation. It will be seen at a glance that this arrangement facilitates packing and unpacking, and furthermore provides easy access to the contents. A person does not need to disarrange everything in his trunk while making a hasty search for some small article; for, since his outfit is packed in drawers of comparatively shallow depth, a cursory glance, or at most a short search, would reveal the desired article. Another great advantage of this trunk is that its contents will not be marred in packing. Ordinarily the bottom layer of goods must bear the weight of all the rest of the outfit, which results in crushing and creasing of delicate dresses, hats, and the like. The lids shown in the illustration serve to prevent a tightly-packed drawer from sticking when opening or shutting, and also provide an efficient protection against the dirt and dust. Three locks are provided for the cover and for each drawer, while strong metal battens brace the trunk against all rough usage. Between the back of each drawer and the rear wall of the trunk are rubber buffers, which will take any shock or pressure on the drawer front. Recesses beneath and back of the front battens form handholds for easy manipulation of the drawers. The entire construction, it will be seen, eliminates all the disadvantages of the ordinary trunk and furthermore, embraces new features which should prove indispensable to the traveler.

**Roman Remains of Great Value Unearthed.**

During the course of some excavations on a mound in the neighborhood of Greenwich Observatory, London, some Roman remains of great value and interest have been unearthed. About two feet below the surface the floor of a Roman room with a great portion of the tessellated pavement intact was revealed. Under careful treatment the beautiful work in cubes of red tile was disclosed, and the space has now been railed off, in

order that the public may view the remains. A fine collection of coins of the period of Hadrian and Constantine was also discovered, together with several pieces of beautifully figured pottery and ornamental wall plaster. The coins were in a state of remarkable preservation, the figures and inscriptions being in some instances almost as clear and distinct as those at present in use. The discoveries are regarded as important for the reason that they prove that the Roman road from London to Dover led through what is now Greenwich Park.

RECENTLY PATENTED INVENTIONS.

Agricultural Implements.

HAY-RACK.—H. P. VOGLER, Waterville, Kans. The hay-rack is so constructed that the front wheels of the wagon on which it is placed may be turned short without danger of cutting the rack. The rack is further constructed so that it will not upset as readily as the ordinary rack, for it has a firm bearing upon the running gear of the vehicle.

Engineering Improvements.

HYDROCARBON-OIL ENGINE.—D. A. BRIGGS, Ewart, Mich. The object of this invention is to provide an engine of simple construction in which the heat of the cylinder is utilized to vaporize the fuel and to heat the mixing air. The hydrocarbon oil is conducted around the cylinder in a spiral tube. Before it reaches the air-mixing chamber it becomes highly heated. After being mixed with air it is exploded by a suitable igniter placed in the cylinder near the top.

SPRAY-PUMP FOR EXPLOSIVE-ENGINES.—J. T. METCALFE, Quincy, Pa. The invention relates to explosive engines in which successive charges of liquid hydrocarbon are first vaporized and mixed with air and then caused to explode. The particular objects of this invention are to make a suitable pump and appropriate connections for use in mechanism of this kind and also to cushion the rebound of the valve used to prevent the retrogression of gases upon the cylinder after each explosion.

FEEDER.—G. M. HILGER, Chicago, Ill. This feeder is adapted for use on boilers, open feed water heaters and the like, and is arranged to feed the liquid compound drop by drop into the feed water to prevent the formation of scales in the boiler.

PUMP.—O. J. BRACKNEY, Butler, Pa. This pump is of simple construction, having no projections such as collars and the like on its outer side, so that it may be readily inserted in a well, or withdrawn therefrom. The invention provides a simple means for fastening the inlet valve in place, whereby it may be easily removed or inserted without the use of a pipe wrench or similar tool.

EXHAUST MECHANISM.—T. D. KLINE, Savannah, Ga. The invention is an improvement in exhaust mechanism for use on locomotives. It consists of the main exhaust flue and an auxiliary exhaust flue opening in its lower end at one side of the main flue and gradually enlarging circumferentially around this main flue above its lower inlet end. Means are provided for controlling the auxiliary flue so that by opening the flue the exhaust is relieved of considerable back pressure.

TIRE-HEATER.—H. J. HENGEVELD, Savannah, Ga., and A. E. ADAMS, High Springs, Fla. The tire-heater is adapted for use in heating tires of locomotives, to permit their removal when worn without requiring the removal of the wheel. In construction the tire heater forms a burner ring which encircles the tire and secures a rapid heating thereof.

Machines and Mechanical Devices.

VOTING-MACHINE.—G. W. LAPRADA, Sago, Va. By this invention, Mr. Laprade provides means whereby the voter may print the names of the different candidates he wishes to vote for on the ballot sheet, which is arranged in the form of a strip wide enough to contain in one line the names of all the candidates to be voted for in the election. Means under the control of the judges of the election are provided for advancing the ballot sheet, which means are also arranged to operate the inking brush and further to operate a register, so that the number of voters that cast their ballots can be determined at any time.

MARKING-MACHINE.—R. N. MOODY, Aberdeen, Wash. This machine is especially useful as a device for marking linen and laundry goods. It comprises one or more type wheels, which may be set at any combination desired, and certain devices for inking the type and impressing the characters on the articles to be marked.

DRIVING DEVICE FOR SHAFTS.—J. HOLTHAUS, Hüllen, Germany. The driving device is more especially designed for revoluble shafts having lengthwise vertical movement. The invention is arranged to prevent or reduce undesirable friction to a minimum and to allow any desired pressure to be exerted lengthwise of the shaft without interfering with the action of the driving device.

Miscellaneous Inventions.

GRATE.—T. H. LUCAS, Minneapolis, Minn. Difficulty has been experienced in burning fine and crumbling fuel, such as peat, sawdust, pea coal and the like, from the fact that the fine particles fall unconsumed through the grate whenever an attempt is made to remove the ashes, thus wasting a large quantity of fuel. The purpose of this invention is to provide a grate capable of retaining all fuel until consumed to ashes and then to remove the ashes without interfering with the unconsumed fuel.

BOTTLE-STOPPER.—JOHN HEARD, Strathroy, Canada. The body portion of the stopper is recessed at its lower end and receives a conical plug which is drawn upward by suitable attachments, thereby expanding the lower

end of the body so that it will fit tightly in the bottle-neck.

PROTECTIVE TUMBLING-HOOD FOR SHIPS' HATCHES.—J. BERGENSEN, New York, N. Y. The hood is conical in shape and mounted at its apex by a ball and socket joint. Because of this fastening the hood under pressure of the wind will tumble in the direction of the wind, so that that portion of the hatch facing the direction of the wind is closed by the hood, while the rest of the hatch is open to permit ventilation. Means are provided for lowering the hood and effectually sealing the hatch whenever desired.

FISHING DEVICE.—J. SEILER, South Norwalk, Conn. The invention relates to a peculiar gang-hook fishing device adapted either for bottom or surface fishing. The hooks project radially from a body portion, and the line is connected to a shank pivoted on the central part of the body portion. When a fish takes the bait the line is drawn up sharply and the hook which engages the fish is allowed to stand still relatively to the other part of the apparatus, the body portion then tilting relatively to the shank of the device. This enables the hook effectively to engage and impale the fish.

CALENDAR.—M. LICHTER, New York, N. Y. The calendar consists of a plate having pairs of slots through which strips of flexible material with the proper letters and numbers thereon are passed. These strips are treated to curl or roll up, so that when unrolled the ends are passed through the slots and immediately curl or roll up on the back of the plate, drawing the front portion of the sheets taut. The curled-up ends not only form means for drawing the displayed portion of the sheets in taut condition, but also form handles for the operator to conveniently take hold of when adjusting the strips.

PAPER-FASTENER.—H. TRENCHARD, JR., Brooklyn, N. Y. The fastener comprises an eyelet adapted to be engaged through the back of an envelope and fingers extending from opposite sides of the eyelet adapted to be passed through the flap of the envelope and turned outward and downward thereon. The material between the openings in the flap forms a cover for the eyelet.

FLAT BRUSH.—W. H. HUMPHREY, New York, N. Y. The invention relates to brushes used by painters, varnishers, and other mechanics, and provides an improvement in flat brushes whereby the bristles are resiliently supported at the front and rear faces of the brush to insure proper flexing of the bristles when the brush is in use and at the same time allowing free flow of the paint, varnish or other material.

ROLL.—J. P. LANGE, Passaic, N. J. The device comprises a number of semi-circular sections placed together, edge to edge, so as to form wheel members. Endless bands of resilient material encircle these wheel members in such manner as to hold them together and also to hold together the oppositely disposed semi-circular sections in each wheel member. Longitudinal rods run entirely through the roll and short bolts secure together the semi-circular sections of each of the wheel members.

NOTE-BOOK.—A. L. HOLTON, Norfolk, Va. The invention is an improvement in tablets in the form of note-books, and especially in books of such character designed for use by stenographers in taking notes. The base-plate of the note-book can be conveniently removed from the baseboard and turned end for end, this being especially desirable when the stenographer has written through the book on one side of the sheets and desires to readjust the book to the baseboard so as to write upon the other side of the sheets.

AIR-HEATER.—A. H. LOVEJOY, Gallia, N. J. This improved air-heater is arranged to utilize the fuel to the fullest advantage and to heat the air and conduct the same in a perfectly pure state into the rooms to be heated. The arrangement is such that each conduit extends from the air-inlet duct through the heater to an individual room without danger of the air being fouled with obnoxious gases and dust.

SAIL FOR MARINE VESSELS.—R. LUNDQUIST, Laguna, de Terminos, Mexico. The inventor has found by practical experience that when a boom and gaff sail is hauled on the wind, the part of the sail nearest the mast and the head of the sail along the gaff are the only parts which actually exercise a propelling effect on the vessel. The other parts merely lie across the course of the wind and tend to heel or tilt the vessel. In this invention provision is made for slacking away a portion of the sail thus avoiding this tilting effect.

GRANULATING ATTACHMENT FOR SALT-SHAKERS.—J. A. MOLLER, JR., New York, N. Y. This invention provides an agitator made of spring wire adapted to be attached to the inside surface of a cap for a salt-shaker. The agitator is so constructed as to extend within the body of the shaker and serves to hold the cap in place without resorting to a thread. Furthermore, its construction is such that upon the slightest turn of the cap forward or backward it will break up or granulate the salt which may have become clogged.

NOTE.—Copies of any of these patents will be furnished by Munn & Co. for ten cents each. Please state the name of the patentee, title of the invention, and date of this paper.

Business and Personal Wants.

READ THIS COLUMN CAREFULLY.—You will find inquiries for certain classes of articles numbered in consecutive order. If you manufacture these goods write us at once and we will send you the name and address of the party desiring the information. In every case it is necessary to give the number of the inquiry. MUNN & CO.

Marine Iron Works. Chicago. Catalogue free.

Inquiry No. 2754.—For makers of bag-sawing machines.

AUTOS.—Duryea Power Co., Reading, Pa.

Inquiry No. 2755.—For manufacturers of water vending slot machines.

"U. S." Metal Polish. Indianapolis. Samples free.

Inquiry No. 2756.—For parties to manufacture a buttonhole cutter.

WATER WHEELS. Alcott & Co., Mt. Holly, N. J.

Inquiry No. 2757.—For makers of diving suits and submarine apparatus.

Handle & Spoke Mch. Ober Mfg. Co., 10 Bell St., Chagrin Falls, O.

Inquiry No. 2758.—For makers of copper, brass or steel lightning rods.

Sawmill machinery and outfits manufactured by the Lane Mfg. Co., Box 13, Montpelier, Vt.

Inquiry No. 2759.—For makers of the Little Giant wood planer, or a combination planer and jointer.

Sheet, bar, rod or wire, cut, formed, any shape. Metal Stamping Company, Niagara Falls, N. Y.

Inquiry No. 2760.—For manufacturers of spring motors.

We design and build special and automatic machinery for all purposes. The Amstutz-Osborn Company, Cleveland, Ohio.

Inquiry No. 2761.—For dealers in automatic machinery for cutting small brass wheels, such as are used in clocks.

Special and Automatic Machines built to drawings on contract. The Garvin Machine Co., 149 Varick, cor. Spring Streets, N. Y.

Inquiry No. 2762.—For manufacturers of combination engine and boiler 4 or 5 h. p., the "Porcupine," preferred.

Manufacturers of patent articles, dies, stamping tools, light machinery. Quadriga Manufacturing Company, 18 South Canal Street, Chicago.

Inquiry No. 2763.—For dealers in essential oils, etc.

Vegetable and fruit-canning machinery wanted. Manufacturers please address with full particulars F. S. Wertz, 319 Franklin St., Reading, Pa.

Inquiry No. 2764.—For makers of match-making machinery.

The celebrated "Hornsby-Akroyd" Patent Safety Oil Engine is built by the De La Vergne Refrigerating Machine Company. Foot of East 138th Street, New York.

Inquiry No. 2765.—For dealers in the "Finger Cork Screw," which folds up into a shell-shaped wood handle, or something similar.

IDEAS DEVELOPED.—Designing, draughting machine work for inventors and others. Charles E. Hadley, 584 Hudson Street, New York.

Inquiry No. 2766.—For a machine for tacking or knotting comfortables or quilts.

Young man, of exceptional mechanical ability, with capital, desires partnership in established manufacturing business. Address "Capital," Box 773, New York.

Inquiry No. 2767.—For makers of machines for rolling and gluing tubes for fire works, such as cannon crackers, Roman candles, etc.

Patents developed and manufactured, dies, special tools, metal stamping and screw machine work. Metal Novelty Works Co., 43-47 S. Canal St., Chicago.

Inquiry No. 2768.—For makers of bobbin turning machinery.

Press work done at short notice. Blanking and drawing our specialty. Estimates cheerfully furnished. Tools for all work made on premises if desired. Copper, brass and nickel plating. Correspondence solicited. Acme Ball-Bearing Caster Co., Chappaqua, N. Y.

Inquiry No. 2769.—For parties to manufacture a bolt of special design.

FOR SALE.—McMechan's Lightning Rotary Bath Brush," just invented. Can take a full bath, except arms and face, from 3 to 5 minutes. Can bathe back with perfect ease. Price for United States ten thousand dollars and royalty. For information enclose stamp. Wm. A. McMechan, St. Clairsville, Ohio.

Inquiry No. 2770.—For dealers in second-hand or new horizontal boring mills for boring out dynamo motor frames.

Send for new and complete catalogue of Scientific and other Books for sale by Munn & Co., 361 Broadway, New York. Free on application.

Inquiry No. 2771.—For dealers in the "Domestic Still."

Inquiry No. 2772.—For dealers in stationary steam boilers fed by kerosene or coal oil instead of coal.

Inquiry No. 2773.—For makers of brass bushings with white pressed therein taking the place of oil as lubricant.

Inquiry No. 2774.—For the manufacturers of the "Portable Ice Machine" formerly made by the Lewis Mfg. Co.

Inquiry No. 2775.—For dealers in telegraph and telephone supplies, also static machines.

Inquiry No. 2776.—For manufacturers of small cast iron specialties, such as toy engines, etc.

Inquiry No. 2777.—For the address of a ship-building or ship windlass company in Canada.

Inquiry No. 2778.—For a partner to help build and patent an improved flying machine.

Inquiry No. 2779.—For dealers in celluloid novelties.

Inquiry No. 2780.—For manufacturers of automobiles.

Inquiry No. 2781.—For makers of horizontal wind mills.

Inquiry No. 2782.—For wholesale dealers in old iron, metal and rubber.

Inquiry No. 2783.—For makers of brass finger rings.

Inquiry No. 2784.—For manufacturers of hygrometers.

Inquiry No. 2785.—For dealers in materials for covering shingles to prevent leaking.

Inquiry No. 2786.—For manufacturers of turbine water wheels.

Inquiry No. 2787.—For machinery for packing preserved provisions.

Inquiry No. 2788.—For dealers in armature toothed punchings.

Inquiry No. 2789.—For complete commutators or segments for small machines.

INDEX OF INVENTIONS

For which Letters Patent of the United States were Issued for the Week Ending

June 10, 1902,

AND EACH BEARING THAT DATE.

[See note at end of list about copies of these patents.]

Table listing various inventions and their patent numbers, including items like Acids, Adding machine, Air brake, Amalgamating apparatus, Antimony treatment, Arch support, Axle lubricating attachment, Band cutter, Bar bell, Bathing tub, Battery grids, Bean sorting machine, Bed brace, Bed rail, Bedstead connecting joint, Beef holder, Belt apparatus, Bicycle, Bicycle fan attachment, Bicycle package carrier, Binder, Binocular glasses, Board, Boiler, Bolt lock, Book, Book section having wide and narrow leaves, Book support, Bottle for aerated liquids, Bottle, non-refillable, Bottle, non-refillable, G. Ferguson, Bottle washing machine, Bottles, cans, etc., Bowling alley foot dampener, Bowling alley score board, Box blank mitering and cornering machine, Brake apparatus, Brake mechanism, Braking force apparatus, Brick for storage bin construction, Brine, vacuum apparatus for boiling, Brooder, Brush, Brush, fountaine marking, Buckle, Bunsen burner, Bustle and hip form, Butter cutting machine, Button cleaning shield, Cable terminal, Caisson air lock, Cake pan, Camera, Camera, photographic, Can heading machine, Can opener, Cans, machine for manufacturing soldered, Cane car unloading machine, Cap machine, Car bolster, Car bolster, railway, Car coupling, Car coupling, J. C. Nelson, Car draft beam, Car door fastening, Car fender, Car tool box, Car ventilator, Carbureter, Carbureter, Roemisch & Orre, Card, playing, Carpet fabric, Carpet stretcher, Cartridge, Cartridge loading machine, Carving machine, Case, measuring, Cash register, Casting apparatus, Cement, making, Chair, A. J. Morley, Cheese cutter, Chemicals in electric furnaces, Chock, R. A. Bockhoop, Cigar, exhibiting and vending apparatus, Cigar or cigarette holder, Cigarette machine, Cigarette machine, H. C. Heckendorf, Circuit interrupter, automatic, Clay, working, Clock, electric, Clothes drying apparatus, Clutch, friction, Coffee pot, Coin controlled machine, Coin holder or bank, pocket, Collar blanks, Collar blocking machine, Combing machine, Combing wool, Commutator segment, Compass, binocular, Compositon of matter, Compress and packer, Concrete conductor, Conveyor, Conveyor end support, Convoyer feeding mechanism, Copping machine, Copper water precipitate for treatment of, Cork extractor, Corn husker and fodder shredder, Corn shock compressor, Corns, etc., device for removing, Crate, folding, Crate, knotdown, Cultivator, Cultivator, T. S. Warner, Cultivator weeder attachment, Curd cutter, Curtain support, adjustable window, Cushion making machine, Cut out, automatic, C. P. Steinmetz.

(Continued on page 438)

Cycles, clamp particularly adapted for securing fittings to the frames of, P. B. H. Seabrook..... 702,160

Cycles, motor cars, etc., brake mechanism for, G. E. Bennett..... 702,337

Damper, stove, W. G. Montgomery..... 702,313

Dental flasks, closing and locking device for, D. A. Baker..... 702,276

Dental instruments, support and switch for electric, E. O. Pieper..... 702,073

Derrick, E. E. Carr..... 701,975

Derrick frame and joint coupling therefor, J. H. Lohner..... 702,227

Derrick, portable, A. Lutz..... 701,906

Detonating composition, H. von Dahmen..... 702,357

Dipping tank, G. M. Henderson..... 702,135

Disinfecting apparatus, C. J. Walz..... 702,041

Dispensing apparatus drip attachment, G. W. Boyd..... 702,181

Display holder, necktie, H. Runtz..... 701,942

Display rack, E. Moore..... 702,232

Display table, C. A. Shaffer..... 702,035

Door, folding, E. H. McCloud..... 702,146

Drag and harrow pulverizer combined, F. B. Seaver..... 702,034

Drawers foot strap, M. D. Wilcox..... 702,121

Drawing frame, J. de Miniszewski..... 701,913

Dredge box, H. B. Williams..... 702,169

Drill, H. R. Jacobs..... 702,217

Drill rod grab, W. W. Campbell..... 702,282

Driving mechanism, reversible, C. S. Parcells..... 702,243

Dust collecting and settling apparatus, C. H. Larson..... 701,898

Dust collector, J. E. Mitchell..... 702,312

Dust guard, P. Martin..... 701,908

Dye and making same, black sulfur, Levinstein & Mensching..... 702,369

Dyeing apparatus, yarn, J. C. Hamer..... 702,002

Excess strength meter joint, T. Bree..... 702,156

Educational device, F. Davenport..... 701,997

Electric light hanger, L. Poole..... 701,930

Electric meter, E. Thomson..... 701,965

Electric motor, H. Rowntree..... 702,155

Electric motors, automatic controller for, N. A. Christensen..... 701,843

Electric switch, J. J. Flint..... 702,364

Electric tube lighting, D. M. Moore..... 702,314 to 702,314

Electrical controlling apparatus, R. F. Platt..... 702,152

Electricity meter, E. G. Holm..... 702,213

Electrodes, forming secondary battery, W. Morrison..... 701,915

Elevator guard, L. I. Fonda..... 702,095

Elevator locking device, M. R. Muecke, Jr..... 702,373

Elevator or storage house construction, S. H. Troman..... 702,118

Elliptical spring, H. E. Smith..... 702,257

Embossing machine, I. Clapper..... 702,283

End gate and fastening therefor, L. F. Fredericks..... 702,053

End gate, wagon, N. Hon..... 701,884

Engines, regulation of speed and power, E. Thomson..... 702,038

Envelope, A. F. Callahan..... 701,839

Envelope, D. H. Keller..... 702,100

Extractor. See Cork extractor..... 702,199

Eyeglet, I. W. Giles..... 701,910

Fabric cutting machine, H. A. Meyer..... 701,914

Fan motor attachment, W. S. Moody..... 702,067

Fastener, expansion, E. J. McCormick..... 702,056

Fastening device, C. D. Hancock..... 701,943

Faucet, filter, Ryan & McEwan..... 702,230

Fence post, J. A. Mitchell..... 702,230

Fibers or filaments from solutions of cellulose, etc., and for twisting and putting into coil form such or other fibers or filaments, apparatus for the production of, textile, C. P. Topham..... 702,382

Filtering press, K. Einsinger..... 702,051

Fire escape, O. Tardif..... 702,259

Fireman's shield, F. W. Shepperd..... 702,036

Fireproof building structure, J. O. Ellinger..... 702,093

Fire starter or gas heater, Draper & Lyon..... 702,049

Fish drying apparatus, A. Morris..... 702,235

Flies from cattle and trapping same, device for crushing, O. B. Gibson..... 701,873

Flue cutting attachment, I. C. Hicks..... 702,349

Fluid pressure brake, H. H. Westinghouse..... 702,269

Flushing tank, closet, L. F. Haynes..... 702,060

Folding machine, L. E. Barnes..... 702,085

Folding stand or easel, J. A. Scott..... 702,033

Ports, construction of, P. J. Nelson..... 701,922

Furnace. See Gas furnace..... 701,986

Furnace terminal, electric, E. G. Acheson..... 701,936

Furniture, combination, J. Moran..... 702,333

Furniture door slide or guide, P. L. Foster..... 702,348

Game or puzzle, Bennett & Zimmermann..... 701,832

Game table, P. W. Cameron..... 702,088

Garment supporter, P. Douglas..... 701,998

Gas apparatus, acetylene, A. W. Edwards..... 702,092

Gas engine, F. L. Nichols..... 702,375

Gas furnace, steam boiler, E. J. Duff..... 701,861

Gas generator, acetylene, A. Davis..... 701,852

Gas lighting device, G. Meier..... 702,311

Gas lighting or extinguishing device, V. Forti..... 702,192

Gas line safety device, J. C. Furman..... 702,195

Gas, purifying acetylene, J. A. Burgess..... 701,995

Gas regulator, S. L. McDams..... 702,236

Gate, H. M. Lockett..... 701,905

Gate, C. B. Johnson..... 702,366

Gearing, variable speed, F. W. Gordon..... 701,876

Gem grinding and polishing apparatus, F. E. Hilliard..... 701,879

Girth fastening, saddle, C. L. Bush..... 701,836

Glass by electrical heating, manufacture of, A. Voelker..... 702,081

Glass cutter, W. L. Barrett..... 702,277

Glass, drawing, J. H. Lubbers..... 702,013 to 702,013

Glasses, lens fastening for, H. H. Waugh..... 702,385

Glazing machine, automatic, B. C. Hemming..... 702,098

Golf tee, C. E. Stocker, Jr..... 702,078

Grain binder, J. I. Ware..... 702,335

Grain cleaner blast regulator, A. T. Ferrell..... 701,866

Grain cleaning machine brush attachment, A. T. Ferrell..... 701,865

Grain drier, J. P. Churchill..... 702,127

Grain drill seed tube, J. W. Poindexter..... 702,114

Grain elevator for separators, S. B. Hart..... 702,058

Grain separating machine, W. L. Belt..... 702,279

Grate, tilting water, H. D. Sawyer..... 701,946

Gravity lock, D. J. Kennedy..... 701,892

Gravity motor, W. O. Benner..... 702,086

Gun, automatic, A. Noble..... 702,240

Gun cleaning tool, A. H. Durston..... 702,359

Gun tower, armored, R. Geelhaar..... 701,870

Hail, preventing device, D. Maggiora et al..... 701,907

Hand wheel, E. H. Seddon..... 702,381

Hanger. See Electric light hanger..... 702,071

Harvester, clover, A. D. Miller..... 701,912

Harvester, husker, and loader, combined corn, J. P. Larson..... 701,899

Heating and metal rolling, system for continuous, T. V. Allis..... 702,084

Heating apparatus, M. M. Johnson..... 702,219

Heating apparatus, steam, C. H. Atkins..... 702,352

Heating systems, fitting for steam, C. A. Ball..... 702,336

Heel, boot or shoe, J. H. Jackson..... 702,137

Hinge, Hulse & Hoover..... 702,304

Hinge joint for connecting rod sections, F. A. E. Hamilton..... 702,204

Hitching post, J. A. Taylor..... 701,964

Hoisting and conveying machine, S. Jackson..... 701,887

Hoop lug, R. B. Moore..... 702,024

Horseshoe, E. B. Fisk..... 702,296

Hydraulic testing machines, automatic gage for, W. Hurrell..... 702,216

Ice machine press, D. L. Holden..... 701,882

Indicating instrument, L. T. Robinson..... 702,052

Induction apparatus, W. Scheidel..... 702,144

Inhaler, E. M. Morgan..... 702,087

Insulating handle connection, G. Brabrook..... 701,847

Insulator, V. G. Converse..... 701,848

Internal combustion engine, C. W. Kelsey..... 701,891

Internal combustion engine, J. S. Rogers..... 702,246

Invalid reclining chair, Amerman & Johannes..... 701,826

Iron or steel, removing scale oxid from the surface of, A. K. Eaton..... 702,050

Ironing board, Parsons & Kain..... 702,069

Ironing board, M. Oneil..... 702,242

Journal box, J. F. Schumacher..... 702,159

Jumper fob, E. R. Mead..... 702,021

Keir for bleaching, etc., W. W. L. Lishman et al..... 702,309

Kettle, L. Gillera..... 702,055

Kneader, dough, M. J. Russell..... 702,248

Label, G. E. Howard..... 702,350

**WOOD or METAL Workers**



Without Steam Power should use our Foot and Hand Power Machinery. Send for Catalogues

A—Wood-working Machinery, B—Lathes, etc.

SENECA FALLS MFG. CO. 695 Water St., Seneca Falls, N.Y.

**ENGINE & FOOT LATHES**

MACHINE SHOP OUTFITS TOOLS AND SUPPLIES

CATALOGUE FREE

SEBASTIAN LATHE CO. CINCINNATI, O.

**Foot and Power Turret Lathes, Planers, Shapers, and Drill Presses.**

SHEPARD LATHE CO., 133 W. 2d St., Cincinnati, O.

**TOOLS**

Every kind of Tool for Steam, Gas, and Water Fitters. Every Tool has our personal guarantee. We have been the Leading Tool Manufacturers for Fifty Years...

WALWORTH MFG. CO., 128 to 136 FEDERAL ST., BOSTON, MASS.

**WORK SHOPS**

of Wood and Metal Workers, without steam power, equipped with **BARNES' FOOT POWER MACHINERY**

allow lower bids on jobs, and give greater profit on the work. Machines sent on trial if desired. Catalogue Free.

W. F. & JOHN BARNES CO. Established 1872. 1999 RUBY ST., ROCKFORD, ILL.



**PERFECT - PUMP - POWER.**

is attained on y in the **TABER ROTARY PUMPS**

They are mechanical simple and durable. Will pump hot or cold fluid, thin or thick. Requires no skilled mechanic. Most power at least cost. All parts interchangeable. Made of iron, steel or bronze. Can be driven by belt, motor or engine attachment. Large illustrated Catalogue free.

TABER PUMP CO., 32 Wells St., Buffalo, N.Y., U. S. A.

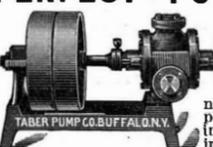

**PALMER MARINE and STATIONARY MOTORS**

2 and 4 CYCLE

are no experiment, as they are in successful operation in all parts of the world. Launches in stock. Send for Catalogue.

PALMER BROS., Cos Cob, Conn.

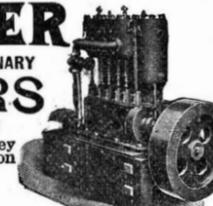

**"WOLVERINE" Gas and Gasoline Engines**

STATIONARY and MARINE.

The "Wolverine" is the only reversible Marine Gas Engine on the market. It is the lightest engine for its power. Requires no licensed engineer. Absolutely safe. Mfd. by **WOLVERINE MOTOR WORKS, 12 Huron Street, Grand Rapids, Mich.**



**If you want the best CHUCKS, buy Westcott's**

Little Giant Double Grip Drill Chucks, Little Giant Drill Chucks, Improved, Oneida Drill Chucks, Cutting-off Chucks, Scroll Combination Lathe Chucks, Geared Combination Lathe Chucks, Plain Universal Lathe Chucks, Independent Lathe Chucks. Made by Westcott Chuck Co., Oneida, N. Y., U. S. A. Ask for catalogue in English, French, Spanish or German. FIRST PRIZE AT COLUMBIAN EXPOSITION, 1893.



**FOR LIGHT AND MEDIUM WORK**

this new 14 inch **B. F. BARNES**

Upright Drill is the best tool made. Substantial, well built, up to date. The driving power is strong and positive—the five-step cone gives wide range of speeds—will drill from 1/16-inch to 3/4-inch. Reading matter on request.

B. F. BARNES COMPANY, Rockford, Ill.

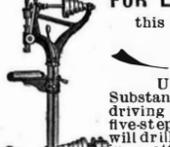

**Gas Engine IGNITER**

Complete with spark coil, \$12.00. The Best Thing on the market. Latest and most improved model. Send for Circular.

Carlisle & Finch Co., 233 E. Clifton Av., Cincinnati, O.

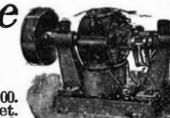

**NEW BINOCULAR.**

(The Tri-Ed.) Small as an opera glass. More powerful than the largest field glass. Send for Circulars.

QUEEN & CO. Optical and Scientific Instrument Works, 1010 Chestnut Street, PHILADELPHIA, PA.



**MORAN FLEXIBLE JOINT**

for Steam, Air or Liquids. Made in all sizes to stand any desired pressure.

Moran Flexible Steam Joint Co., Inc'd, 149 3d East St., LOUISVILLE, KY.



**Automatic Machines FOR FORMING WIRE**

from coil into shapes similar to cuts. We can furnish machines or goods, as desired. Send for Catalogue.

BLAKE & JOHNSON, WATERBURY, CONN. O. Box 7,

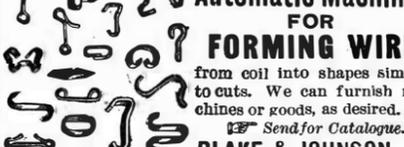

Labels, machine for inserting and fastening strings in, S. B. Tilly et al..... 702,262

Lamp burner, S. B. Horss..... 701,919

Lamp, electric tube, D. M. Moore..... 702,319

Lamp, gas, T. Maguire..... 702,143

Lamp glower and making same, pyroelectric, C. P. Steinmetz..... 701,959

Lamp holder, electric incandescent, E. G. Sheppard..... 701,949

Lap robe, J. T. Forster..... 702,297

Latch, G. H. Pierce..... 702,074

Latch, A. Charles..... 702,185

Leather stretching machine, J. Caldwell..... 701,838

Leather working machine, J. K. Miller..... 702,023

Line grip, F. L. Ferre..... 702,191

Linotype machine, J. B. Bell..... 701,989

Liquid pressure regulator, M. Pink..... 702,075

Liquid gas, device for charging or discharging, S. W. Miller..... 702,066

Lock. See Bolt lock. Gravity lock..... 702,333

Lock, M. Schrauder..... 701,850

Locks, extension cylinder for pin, A. Crumond..... 702,005

Locomotive draft regulator, O. Horenz..... 702,116

Loom fabric scouring attachment, P. Spindler..... 702,346

Loom shifter mechanism, C. M. Day..... 702,281

Loom shuttle, C. N. Brown..... 701,938

Loom thread parting mechanism, C. F. Roper..... 701,973

Looms, means for defining the beat of the lay of, C. H. Warren..... 701,934

Looms, tuft yarn spool for tufted-pile fabric, J. F. Riddell..... 702,330

Magnet holding and adjusting apparatus for compensating binnacles, A. M. Ritchie..... 702,228

Mail box, S. A. Jones..... 702,193

Mat cutter, C. Arnold..... 702,200

Measure, lumber, J. R. Greene..... 702,203

Measuring apparatus, liquid, Marchbank & Bidstrup..... 702,019

Measuring case, A. R. & H. G. Wornwood..... 702,083

Mechanical movement, J. D. A. Johnson..... 702,099

Merchandise transfer apparatus, A. W. Swanzitt..... 701,961

Metallic sulfids soluble, rendering, C. G. Collins..... 702,047

Metallurgical filter, F. H. Long..... 702,064

Milk cooler, W. L. Haley..... 702,134

Milker, cow, D. Y. Wilson..... 702,386

Mill. See Windmill..... 701,979

Mines, machine for extracting coal in pieces from, C. Wisemann..... 702,147

Mining machine, J. M. McHugh..... 702,043

Mitering machine, J. T. Ziska..... 701,931

Milton, C. C. Pratt..... 701,911

Moistener, stamp and envelop, C. W. Millar..... 701,830

Mold flask partition, H. W. Bell..... 702,183

Molding press, J. F. Buckley..... 701,985

Mopping device, H. F. Ackerman..... 702,328

Mosaic work, making, J. S. Parker..... 701,827

Motion, apparatus for converting rotary into reciprocating, R. H. Yale..... 701,857

Motor, Dieter & Orum..... 702,371

Motor driven device or mechanism, H. A. Meyer..... 702,109

Motor shut-off device, T. D. Millea..... 702,031

Muffler, A. G. Ronan..... 702,224

Musical instrument, H. Langfelder..... 702,250

Mussels, drag for gathering, J. W. Sharp..... 702,325

Nitroglycerin, apparatus for the manufacture of, F. L. Nathan et al..... 702,363

Nut lock and key, J. F. Fierke..... 701,952

Nut wrench, C. C. Smith..... 702,002

Oil burner, J. Johnson..... 702,377

Oil burner, J. B. Payne..... 701,902

Oil burner, crude, T. E. Lewis et al..... 702,070

Oil can, W. J. Paul..... 702,068

Oil cup, J. B. L. McKenzie..... 702,172

Oils and products produced thereby, effecting the drying of non-drying, W. N. Blakeman, Jr..... 701,859

Ore concentrator, W. G. Dodd..... 701,851

Ore separator, J. J. Hopper..... 701,851

Ore separator and classifier, C. Guiver..... 702,184

Ore separator, magnetic, J. W. Carter..... 701,860

Oxidizing apparatus, A. N. Dubois..... 702,104

Oyster tongs, M. Lawrence..... 701,970

Package for grain products, T. F. Wales..... 701,845

Package, shipping, F. W. Collins..... 702,170

Paint compound or mixture, W. N. Blakeman, Jr..... 702,175

Paints, manufacturing, W. N. Blakeman, Jr..... 702,365

Pan. See Cake pan..... 702,338

Paper box machinery, creasing or scoring and mitering mechanism for, C. W. Gay..... 702,205

Paper hanger's tool, T. E. Boord..... 702,142

Paper, making, J. B. Hanscom..... 701,856

Paper pulp, etc., bleaching, F. H. Long..... 702,329

Peat press, A. A. Dickson..... 702,030

Photometric recorder and indicator, J. Poliakoff..... 702,177

Piano, pneumatic, S. K. Reynolds..... 702,178

Pigment and producing same, W. N. Blakeman, Jr..... 702,174

Pigments and products produced thereby, treating, W. N. Blakeman, Jr..... 702,173

Pigments, imparting drying properties to, W. N. Blakeman, Jr..... 701,984

Pillow sham holder, M. A. Yemmer..... 702,249

Pipe, T. M. Saurman..... 701,999

Pipe fittings or joints, non-conducting covering for, J. W. Farley..... 702,079

Pipe wrench, G. H. Swarthout..... 702,253

Pipe wrench, J. F. Stempfer..... 701,841

Plaiting machine roll, D. L. Chandler..... 702,341

Planing machine, W. W. Carey..... 702,327

Planter, A. J. Owens..... 702,022

Blow attachment, disk, M. Mecum..... 702,288

Plumb bob, H. M. Curry..... 701,869

Pneumatic despatch system, H. W. Forslund..... 702,367

Pneumatic transfer tube system, F. W. Jones..... 702,108

Pool games, etc., combined frame and register for, E. R. Marshall..... 701,992

Post hole digger, D. A. Bowen..... 702,280

Power transmitting mechanism, A. T. Brown..... 702,305

Precious metals from their ores, extracting, E. D. Kendall..... 702,139

Press. See Filtering press. Ice Machine press..... 702,252

Printing machine, E. Lee..... 702,129

Printing machine, blue, C. Spaulding..... 702,245

Propeller controller, W. Cooper..... 702,334

Pump, A. Radovanovic..... 702,054

Pump pipe grapple, L. N. & S. H. Schulte..... 701,878

Pump valve, vacuum, W. F. Garrison..... 702,188

Punch, pocket knife leather, O. L. Harrison..... 702,284

Puzzle, Elliott..... 701,901

Puzzle, M. Cody..... 702,342

Quilting frame, T. Lewis..... 702,215

Radiator valve actuating mechanism, W. P. Clough..... 701,849

Rail joint, E. P. & H. C. Hunter..... 701,902

Rail joint and tie plate, combined, T. Cosgrove..... 702,141

Railway clearing house, A. W. Swanzitt..... 702,113

Railway construction, G. L. de Lencheres..... 702,231

Railway switch, L. Palmer..... 702,211

Railway track sanding device, A. C. Monfort..... 702,343

Railway train guard, antitelescoping, W. B. Heyburn..... 701,980

Range and water heater, combined, H. W. Conner..... 702,062

Receptacle for holding and delivering aromatic substances, E. O. Witman..... 701,935

Recorder. See Photometric recorder..... 701,955

Refrigerating apparatus, E. W. Howell..... 702,368

Register, B. G. Robbins..... 702,207

Registering device, automatic, R. R. Spears..... 701,885

Rein holder, T. Keefer..... 702,331

Rein support, S. E. Harsh..... 702,303

Retort, E. H. Hopkins..... 702,214

Rocking and reclining chair, adjustable, J. M. J. Babcock..... 702,275

Rolling machinery, E. W. Hopkins..... 702,290

Rope clasp, W. N. Hull..... 702,308

Runaways, device for arresting, F. E. Arnold..... 701,877

Sad iron handle, C. T. Demarest..... 702,089

Safety pin, G. W. Light..... 701,966

Sanding machine, O. S. Hammond..... 702,089

Sash fastener, detachable window, A. L. Day..... 701,966

Sash lock, J. H. Thornton..... 701,966

**THE Dr. Deimel Underwear**

Why wear prickly, irritating wool next the skin during warm weather when you can secure real comfort by wearing the cool, cleanly Dr. Deimel Linen Mesh Underwear.

**Free Booklet and Samples of the Cloth Sent by Addressing**

**The Deimel Linen-Mesh Co., 491 Broadway, New York.**

SAN FRANCISCO, CAL., 6th floor, Hayward Bldg. WASHINGTON, D. C., 726 Fifteenth St., N. W. MONTREAL, CAN., 2302 St. Catherine St. LONDON, E. C., ENG., 10-12 Bread St.

The Dr. Deimel Dress Shields are the best made. They can be easily washed and are odorless. We guarantee every pair.



**THE EUREKA CLIP**

The most useful article ever invented for the purpose. Indispensable to Lawyers, Editors, Students, Bankers, Insurance Companies and business men generally. Book marker and paper clip. Does not mutilate the paper. Can be used repeatedly. In boxes of 100 for 25c. To be had of all booksellers, stationers and notion dealers, or by mail on receipt of price. Sample card, by mail free. Manufactured by **Consolidated Safety Pin Co., Box 121, Bloomfield, N. J.**

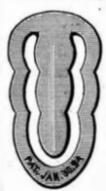

**IROQUOIS MACHINE COMPANY**

Manufacture under patents Improved Universal, Plain, Disc, Face **GRINDING MACHINES** WIRE DRAWING MACHINERY

150 Nassau Street, NEW YORK U. S. A.



**ACETYLENE GAS LIGHTING**

Reduced to the Most Efficient, Safest, Simple and Economical Use. We guarantee our machines perfectly automatic in action, to extract all the gas from the carbide, and absolutely no overproduction or loss of gas. Approved by the various Boards of Fire Underwriters. Standard sizes 10 to 150 lights. Exclusive territory given to responsible agents. Correspond with **Niagara Falls Acetylene Niagara Gas Machine Co., Falls, N. Y. & Can.**



**Robert Fitzsimmons' System**

**A. J. DREXEL BIDDLE says:** "His thorough scientific knowledge of anatomy makes him a particularly able instructor in physical development."

However badly run down or weak you may be, I can make you healthy. By a series of simple, health-giving exercises, specially planned for you by letters, I can build you up and put your body in thorough condition. My method **beats drugs.** I can give you a good appetite and a digestion to match it. You can enjoy every moment of the day and sleep soundly all night. The clear, alert brain and power of endurance that I can give you will place you in the lead and bring you success. **No more headaches;** no more watching the clock for quitting time. I can replace your fat with firm muscle and strengthen your lungs. Constipation and other disorders disappear. **Age makes no difference. I am 42 years old myself.** Physical culture keeps me healthy. Everybody who has used it praises my common-sense system of exercise. I can refer you to such men as

**V. S. SENATOR PENROSE**  
**A. J. DREXEL BIDDLE**  
**TRUXTON HARE** (the most celebrated half-back in the country)  
**THOMAS A. EDISON, Jr.** and scores of other prominent people.

Write for my illustrated booklet, which tells you about terms and contains much valuable information regarding the preservation of health. Address

**The Robert Fitzsimmons Institute of Physical Culture**  
Bensonhurst, New York  
Robert Fitzsimmons, Director & Gen'l Mgr.

## The World's Playground

Colorado,  
Michigan, Canada,  
The Adirondacks,  
St. Lawrence River,  
White Mountains,  
or the  
Sea Coast of New England

Best reached by the

# "Big Four"

Write for Rates and Folders.

Warren J. Lynch, W. P. Deppe,  
Gen'l Pass. & Tkt. Agt. Asst. Gen'l P. & T. A.  
CINCINNATI, OHIO.



Patton's Sun Proof Paints

Last twice as long as white lead paints; cover much more surface; never dis-appoint; guaranteed for five years. Advice on painting and choice of colors FREE—book FREE.

PATTON PAINT CO.  
227 Lake St., Milwaukee, Wis.

## BURNISHINE

The most marvelous metal polish in the world.



Contains no Acids or anything injurious to the Metal or Hands. Produces a wonderful brilliant lustre on Brass, Copper, Tin, Zinc, Silver, Nickel and all Metals. A few rubs and the article is handsomely burnished. Will not soil the hands or leave deposits in corners or surface of the metal. Will restore burnt or rusty Nickel on Stoves to its original lustre. Put up in cans at prices as follows: 1/2 Pint, 25c. 1 Pint, 40c. 1 Quart, 60c. If your dealer does not keep it write direct to J. C. PAUL & CO., 39 Dearborn St., Chicago.

# TOOLS FOR MECHANICS.

Send for Free Catalogue No. 16 B.

The L. S. Starrett Co., Athol, Mass., U. S. A.

## The "Best" Light

is a portable 100 candle power light, costing only 2 cts. per week. Makes and burns its own gas. Brighter than electricity or acetylene, and cheaper than kerosene. No dirt. No grease. No odor. Over 100 styles. Lighted instantly with a match. Every lamp warranted. Agents Wanted Everywhere.

### THE "BEST" LIGHT CO.

87 E. 5th Street, CANTON, OHIO.

## Apple Economical Gas Engine Igniters.

Are positively the best built for Stationary, Automobile and Marine Gas Engines, either touch or jump spark system. We are the leaders in the manufacture of igniting Dynamoes, Magnets, Governors, Coils, Plugs, etc. Write for printed matter. The Dayton Electrical Mfg. Company, No. 80 South St. Clair St., Dayton, Ohio, U. S. A. New York stock carried by Chas. E. Miller, 87 Beade Street, N. Y.; Philadelphia Office, The Bourse; Chicago Office, 19-21 La Salle Street. St. Louis stock carried by A. L. Dyke, Linmar Building.



## Steady Light with Gasoline Engines.

16 to 300-light dynamos. The only dynamos made that give right results. Write us.

The Hobart Electric Mfg. Co., Troy, Ohio.

# SHELBY

## GOLD DRAWN SEAMLESS TUBING.

SHELBY STEEL TUBE CO., Pittsburg, Pa.

## Search Lights, Electric Gas Lighters, Automobile Lighters.

Push the "plate" or lever, it lights. For all uses where candles, lamps, etc., are dangerous. \$2 by mail or express prepaid. Extra batteries, 35 cents.



NEW STANDARD Electric Searchlight.

Locomotive and Gas Stove Lighter. Money makers for bright people. Agents wanted.

WM. ROCHE, Inventor and Sole Mfr., 42 Vesey Street, New York, N. Y.

D. L. HOLDEN REAL ESTATE TRUST BLDG PHILA., PA. SOLE MANUFACTURER. REGELED ICE MACHINES. SEE FIRST PAGE SCIENTIFIC AMERICAN SEPT. 2, 1899.

Saw clamp, W. I. Kirk.....	701,897
Saw sharpening device, O. E. Peiseler.....	702,150
Sawing machine, automatic cut off, W. M. Dwight.....	702,360
Scale, spring balance, J. L. Mauldin.....	702,020
Scissors or shears, D. McKenna.....	701,238
Screw bolts, etc., apparatus for extracting, P. L. Senn.....	701,948
Screw driver, E. G. Rowlands.....	701,941
Sealing implement, H. W. Abbott.....	702,351
Secondary battery, W. Morrison.....	701,917
Sewage disposal plant, G. Anderson, et al.....	701,827
Sewing machine, A. W. Eaton.....	701,862
Sewing machine, button, A. Giacomini.....	701,871
Sewing machine table and guard attachment combined, E. H. Ahrens.....	701,824
Shade bracket, automatic extension, A. H. Ousley.....	702,112
Shaft support and coupling, combined, H. Harden.....	702,300
Sheet metal disk or cap feeding machine, automatic, J. P. Wing.....	702,388
Sheet metal folded joints, machine for the production of, T. L. Carbone.....	702,046
Shoe fastener, Kinnear & Jonah.....	701,896
Shoe polisher, E. De Baum.....	702,289
Shoe turning device, G. B. Gardner.....	702,196
Show, J. F. Haviland.....	702,047
Show case, A. Faeger.....	701,888
Shutter, window, J. L. Nettleton.....	702,148
Sifter spout, flour, H. R. Roberts.....	701,936
Signs, switchboard for illuminating electric lamp, Norden & Crandall.....	702,149
Skate clamp, J. H. Morrison.....	702,145
Sled, A. F. Lagerstrom.....	702,306
Smoothing iron, B. F. Albaugh.....	701,825
Soda water apparatus, R. M. Green, Jr.....	702,132
Soda water apparatus, R. M. & R. M. Green, Jr.....	702,133
Soda water fountains, syrup cook for, R. M. Green, Jr.....	702,131
Soldering machine, side seam, H. B. Williams.....	702,168
Speed of vehicles, instrument for indicating and recording the, J. Nutry.....	702,110
Spinning artificial silk filaments for forming strands or threads, apparatus for, R. W. Strehlenert.....	702,163
Sponge substitutes, forming, A. Straus.....	702,162
Spring, See Elliptical spring.....	
Spur riding, C. W. Davison.....	701,854
Stamp affixer, B. H. Calkin.....	701,996
Stamp, time, S. G. Miller.....	702,229
Staple forming and driving mechanism, W. Edge.....	702,091
Starting or stopping mechanism, A. Giacomini.....	701,872
Steam, controlling the generation of, C. Musker.....	701,921
Steam generator, J. Kilshaw.....	701,895
Stone surfaces, machine for working, T. Stigitz.....	702,037
Storage battery, A. D. Edgerton.....	702,361
Store service apparatus, M. C. Swezey.....	702,080
Stove, range, etc., F. Anshutz.....	702,274
Strap grip for snaddling horses, etc., J. H. Wallace.....	702,166
Stroke regulator, R. H. Yale.....	701,883
Surveying instrument, J. Beal.....	702,354
Switch, outlet box, adjustable, J. H. Rusby.....	702,247
Switch throwing device, C. C. James.....	701,889
Switch throwing device, locomotor, A. C. Wolfe.....	702,042
Synchronizing alternators, R. E. Huthstener.....	701,886
Synchronous motion to distant points, means for transmitting, L. Saxon.....	701,947
Syringe box, fountain, A. C. Eggers.....	702,187
Syrup cooling apparatus, W. Walter.....	701,971
Table, H. M. Hanson.....	702,057
Taps, device for removing broken, J. Kinvall.....	702,011
Telegraphic apparatus, S. G. Brown.....	702,339
Telegraphic transmitter, automatic, J. A. Toomey.....	702,263
Telephone switchboard, J. M. Overshiner.....	702,028
Telescope, A. A. Common.....	702,048
Tennis net, table, J. H. & W. C. Quiggin.....	702,154
Test cup, W. W. Emmons.....	702,302
Thermometer, clinical, Windolph & Stofer.....	702,387
Thill, vehicle, H. G. Brough.....	701,994
Threshing machine, R. Davis.....	702,345
Threshing machine band cutter, G. F. Conner.....	701,846
Ticket holder, A. S. Adams.....	702,045
Ticket holder, theater or transportation, E. O. Loomis.....	702,107
Tile, building, E. S. Lafferty.....	702,103
Tile, roofing, A. Gustaf.....	702,202
Tilting gate, B. A. Fisher.....	701,868
Timepiece, geographical, C. E. Davis.....	701,853
Tire, elastic, W. F. Williams.....	702,271
Tobacco cutter, W. W. Watson.....	701,974
Tobacco, etc., extractor for plug, A. J. Feild.....	702,294
Tobacco, manufactured, W. A. Fretwell.....	702,130
Tobacco steamer, C. M. Armstrong.....	702,123
Tobacco stringing machine, C. G. Wells.....	702,267
Tongue support, S. Ebersole.....	702,291
Tool handle, F. Ewing.....	702,190
Tooth crown, artificial, J. C. Osborne.....	702,111
Toy, explodable paper, Lynch & Hibson.....	702,065
Trace carrier, W. E. Dippert.....	701,858
Train pipe coupling, G. L. Bonham.....	701,833
Trolley crossover, T. North.....	701,925
Trowel grinding machine, H. Beltz.....	701,831
Truck, friction driven, J. P. McElroy.....	702,025
Trunk or package binder, C. C. P. McCord.....	702,322
Truss, hernial, M. E. Smith.....	701,954
Truss, metal, E. W. Samer.....	702,332
Tube drawing grip, H. Oberjohann.....	701,926
Tube machine, J. J. Gartry.....	702,197
Tubing, manufacture of bent, J. P. Buckley.....	702,125
Tumbling barrel, sand blast, B. C. Tilghman, Jr.....	702,040
Turbine, steam, J. Burgum (reissue).....	11,999
Type distributing machine, Hodgkin & Kenney.....	701,881
Type writing machine word counting attachment, H. B. Sary.....	701,840
Unloading scows, etc., apparatus for, T. P. Payne.....	702,029
Valve, E. Webb.....	702,266
Valve, J. W. Nethery.....	702,326
Valve, check or pump, R. Kreher.....	702,223
Valve, engineer's, N. A. Christensen.....	701,842
Valve for internal combustion engines, exhaust, J. Saltar, Jr.....	701,944
Valve for steam passages, water and air relief, C. H. Atkins.....	702,353
Valve governing mechanism for engines, inlet, J. F. Duryea.....	702,000
Valve regulator and governor, J. F. McElroy.....	702,026
Valve, relief, F. Schreidt.....	702,157
Valve, stop, W. G. Tyson.....	702,383
Vehicle, J. F. Hathaway.....	702,059
Vehicle brake, W. A. Critchlow.....	702,287
Vehicle, motor, J. D. Maxwell.....	701,909
Vell fastener, A. Bippart.....	701,991
Vending machine, J. C. de Janisch.....	702,218
Ventilated box, L. D. Lewis.....	702,106
Ventilator, See Car ventilator.....	
Wagon, S. D. Reynolds.....	701,933
Wagon, chute, E. L. Keyes.....	701,894
Wash tub, F. C. Kainer.....	702,221
Washing machine, Boorman & Sharp.....	702,355
Watch dial, W. Brack.....	701,993
Water meter, disk, W. H. Larrabee.....	702,225
Water meter, disk, F. L. Northrop.....	702,241
Waterproof coat, G. A. & A. Strom.....	702,256
Water wheel, S. Shultz.....	702,251
Weather strip, B. M. Whiting.....	702,270
Well casing and strainer, J. G. Huffman.....	702,006
Well casing perforating device, T. E. Clark.....	702,128
Wheat cleaning mechanism, J. Higginbottom.....	702,212
Windmill, G. B. Snow.....	702,161
Winding machine conical tube holder, C. E. Riley.....	702,076
Window lock, S. J. Gibboney.....	702,198
Window screen, J. H. Rankin.....	701,932
Window screen, M. R. Skinner.....	702,077
Window screen, adjustable, D. E. Fleming.....	702,094
Wire stretcher, H. L. Ferris.....	702,295
Woodworking machine holddown device, J. E. Thomas.....	702,039
Wrench, F. C. Peabody.....	701,929
Wrench, W. Shirk.....	701,951

## The Art and Science of Photography

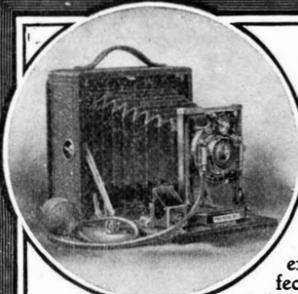

are exemplified by the work of Premo Cameras, instruments incorporating all the important ideas that have attended the development of picture taking. In all classes of work, Premo Cameras excel because of their accurate adjustments and perfect workmanship. In price, they range from \$11.00 to \$250.00, according to size and equipment.

# PREMO Cameras

are always the same in quality.

One of the most efficient cameras for every-day use is Pony Premo No. 4, pictured in the upper circle. It possesses in compact form every requisite for the best results with either plates or films. The price is but \$20.00. A camera that will last a life time and always be a source of satisfaction.

Ask your dealer to show you Pony Premo No. 4, or send at once for the new Premo Book. FREE.

Dept. W. ROCHESTER OPTICAL CO., Rochester, N. Y.

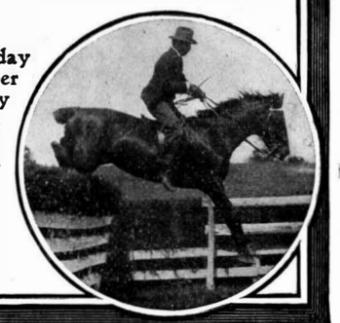

We want every fuel gas company to send for a sample

Our range has stood well at the top in every competitive test

### GOLD COIN GAS RANGES

have been on the market only a year, but we have been making stoves since 1865. We are ready to "show you" that our ranges are right and prices decidedly interesting. Perfect combustion, economical fuel demands, double walls throughout, leg base if desired. Builders will find it worth while to get our quotations at once.

The Chicago Stove Works, (Est. 1865.)  
22d Street and Blue Island Avenue, Chicago, Ill.

## The Risk of Summer Travel

The greater amount of travel in the summer time increases personal risk. We insure you against loss of income resulting from accidents if you take out

### An Accident Policy

in The Travelers Insurance Company, of Hartford, the oldest, largest and strongest Accident Insurance Company in the world. These policies guarantee a weekly income while disabled and large amounts for loss of legs, arms, hands, feet or eyes. If death ensues, a stated sum is paid. \$75,000,000 have been distributed among 37,000 policy holders or their families for injuries or death.

### A Life Policy

in The Travelers Insurance Company provides safe insurance at a lower guaranteed net cost than mutual companies, which charge for insurance and give such a share in the profit as the company sees fit. The Travelers charges for insurance only. The net cost of a policy in The Travelers is, therefore, guaranteed and known beforehand, and the difference is in your pocket first to last.

Agents in every town or write for interesting literature.

## The Travelers Insurance Company

Hartford, Conn.  
(Founded 1863)

## "AMERICA'S SUMMER RESORTS"

This is one of the most complete publications of its kind, and will assist those who are wondering where they will go to spend their vacation this summer. It contains a valuable map, in addition to much interesting information regarding resorts on or reached by the

### NEW YORK CENTRAL LINES

A copy will be sent free, postpaid, to any address on receipt of a two-cent stamp, by George H. Daniels, General Passenger Agent, New York Central & Hudson River Railroad, Grand Central Station, New York.

## "TANDEM" and "PEERLESS" Gas & Gasoline Engines

Write for particulars

Northern Engineering Works,  
641 Atwater St., Detroit, Mich.

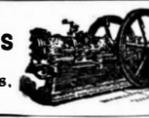

### THE BRIGHT WHITE LIGHT FOR MAGIC LANTERNS

Also for Bromide Enlarging, Copying, Photo-Engraving. Intensely brilliant, very portable, burns kerosene, costs 1 cent per hour. Send for lists including Stereopticons, Moving Pictures, Slides and Microscopes.

WILLIAMS, BROWN & EARLE,  
Dept. 6, 918 Chestnut St., Philadelphia.

### 12-inch Pipe cut off and Threaded with ease by one man and a

## FORBES PATENT DIE STOCK

Smaller sizes proportionately easy. Send for Catalogue.

THE CURTIS & CURTIS CO.,  
MACHINE No. 30, Range 4-2 in. R. & L., 6 Garden St., Bridgeport, Conn.

## Paint or Whitewash the Easy-Economical Way

Why do by hand, that which can be more cheaply, and quickly done by machinery?

### Hook's Pneumatic Coating Machine Equals Twenty Men With Brushes

will paint or whitewash in one-tenth the time it takes by hand, with better results as to appearance and durability; cleaner than brush-work; no scaffolds nor ladders required. No one spending \$35.00 for painting or whitewashing can afford not to have this wonderful labor-saving device. Anyone can operate it. Figure out the saving in labor.

### "STAY-THERE" PAINT

(Weather-proof and Fire-proof)

A substitute for oil paint at one-fifth the cost. Better and as cheap as whitewash. Our twenty-four page book tells the tale. We shall appreciate your enquiry.

F. E. HOOK, 11-27 Hook Bldg., Hudson, Mich., U. S. A.

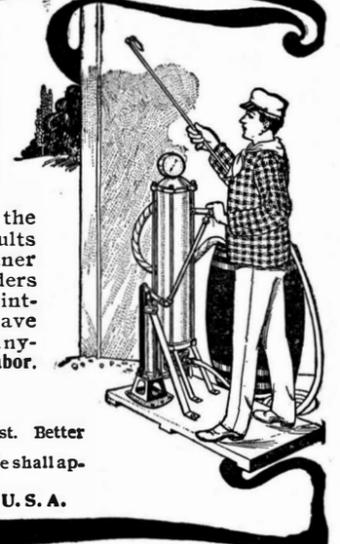

**MENNEN'S BORATED TALCUM TOILET POWDER**



A Positive Relief For PRICKLY HEAT, CHAFING, and SUNBURN, and all afflictions of the skin. Removes all odor of perspiration. Delightful after Shaving. Sold everywhere, or mailed on receipt of 25c. Get Mennen's (the original). Sample Free. GERHARD MENNEN COMPANY, Newark, N.J.

**CREST 3, 5, 7 H. P. MOTORS.**



Sparking Pugs and Coils. CREST MFG. CO., Cambridge, Mass.

# Telephones

Each telephone its own Central, one movement to call, nothing to turn back. Saves half your time without using unreliable automatic attachments. Only one movable part, nothing to get out of order. The only Central Battery and Central Coil System in use. Especially desirable for business plants of five to twelve stations, radius of 1,000 feet. Efficiency guaranteed.

Office of SCIENTIFIC AMERICAN equipped.

**SPENCER ELECTRICAL CO.,**  
163 Greenwich St., New York.

**The Buffalo Universal Handy Bench Clamp**



Indispensable for workshop. Is as essential to a kit of tools as hammer or saw.

**E. E. JOSEF MFG. CO.**  
Buffalo, N. Y.

# DIXON'S GRAPHITOLEO

An all around lubricant for Cylinders, Engine Slides, Chains, Gears, Etc. of Automobiles. It is made of pure vaseline and Dixon's No. 635 Graphite. It is equally useful for general use.

Small Sample Free.

**JOSEPH DIXON CRUCIBLE CO.**  
Jersey City, N. J.

**STANDARD INDEX CARD CO.**  
112-114 N. Seventh St., Philadelphia, Pa.

RECORD, TAB & GUIDE CARDS.

Plain Printed, Ruled & Accurately Die Cut For all makes of Cabinets Quality Execution & Promptness Guaranteed Odd Size Guides and No. of Projections or Alphabetical Subdivisions MAIL US SAMPLE WHOLEY PRICES

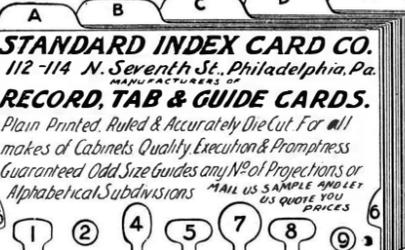

**VELOCITY OF ICE BOATS.—A COLLECTION** of interesting letters to the editor of the SCIENTIFIC AMERICAN on the question of the speed of Ice Boats, demonstrating how and why it is that these craft sail faster than the wind which propels them. Illustrated with 10 explanatory diagrams. Contained in SCIENTIFIC AMERICAN SUPPLEMENT, No. 214. Price 10 cents. To be had at this office and from all newsdealers.

# DUCCI

or Duplicate Cribbage

**The New Scientific Card Game**

The question "who plays the best game of cribbage" settled scientifically.

Write for full description and secure exclusive territory rights. Ducci boards \$1.50, \$2.00 and \$2.50.

**DUCCI COMPANY,**  
101 Wood St., Pittsburgh, Pa.



**RESTFUL SLEEP**

In Camp, on the Yacht and at Home.

**"Perfection" Air Mattresses,**  
CUSHIONS and PILLOWS.



Style 6L Camp Mattress with Pillow attached. Also showing Mattress deflated.

Clean and Odorless, will not absorb moisture. Can be packed in small space when not in use.

Send for Illustrated Catalogue.

**MECHANICAL FABRIC CO., PROVIDENCE, R. I.**

Writing attachment, J. C. Fink..... 701,867  
Writing machine carriage, J. T. Schaaff.... 702,379

**DESIGNS.**

Badge, J. B. Nolin.....	35,936
Box, paper, R. L. Myers.....	35,944
Bureau or similar article, M. V. Hammack	35,948
V. Hammack.....	35,947
Bureau of similar article of furniture, M.	35,943
Calendar, H. Doyle.....	35,940
Clock case, P. Tietgens.....	35,940
Cup, S. Linz.....	35,942
Floor covering, mosaic, E. D. Weary.....	35,949
Monument, E. M. Wolff.....	35,950
Name plate, W. D. Hamilton.....	35,939
Picture frame, M. V. Hammack.....	35,935
Scale base, O. O. Ozias.....	35,941
Sidetable or similar article, M. V. Hammack	35,946
Stone, cut, E. G. H. Scheick.....	335,937
Trimming, G. H. Taylor.....	35,952
Type, font of printing, E. Everard.....	35,945
Vehicle body, W. S. Rogers.....	35,951

**TRADE MARKS.**

Baking powder, S. E. Bleyer.....	38,429
Balm or lotion, A. E. Cox.....	38,434
Bits, stirrups, spurs, and buckles, Smith,	38,446
Worthington & Co.....	38,446
Boiler incrustation, preparations for prevention of, Land and Marine Supply Company	38,440
Boots and shoes, Isaac Prouty & Co.....	38,422
Cigars, Mason & Haralson.....	38,427
Cigars, cigarettes, and smoking tobacco, A. Plot	38,428
Cosmetics, hair oils, hair tonics, and hair dyes, Theo. A. Kochs Company.....	38,432
Cotton dress goods, printed, Edlystone Mfg. Co.	38,418
Dentifrice, C. H. Stadlinger.....	38,435
Eyeglasses and spectacles, nose guards for, Borsch & Co.....	38,417
Food in tablet form, fattening, J. W. Shults	38,431
Food preparations from cereals, vegetables, and legumes, Real Food Co.....	38,430
Furnaces, soft coal, F. Flehoger.....	38,447
Hosiery, F. E. Mistrot.....	38,421
Medicines for certain named diseases, proprietary, E. Stevens.....	38,438
Mineral substances used in manufactures, certain named raw or partly prepared, Magnesia Syndicate.....	38,441
Musical instruments and parts thereof, automatic playing attachments for, Playano Manufacturing Co.....	38,443
Remedy, blood, nerve and kidney, A. B. Seelye	38,437
Remedy for affections of the nerves, Peter-Bauer Drug Co.....	38,436
Sewing and typewriter machines, Pacific Hardware & Steel Co.....	38,444
Sheetings, cotton, Anderson Cotton Mills.....	38,419
Shirtings, sheetings and drills, E. L. Surferlin	38,420
Shoes (Gilmmer Bros.).....	38,424
Shoes, J. J. Julia & Co.....	38,425
Shoes, cushion, A. Reed.....	38,423
Toilet preparations, certain named, Theo. A. Kochs Company.....	38,433
Veterinary compound for external use, liquid antiseptic, J. P. Carback.....	38,439
Washboards, American Washboard Co.....	38,445
Whisky, J. E. Ahrens.....	38,426

**LABELS.**

"Belgian Soap," for soap, W. C. Ballowitz	9,214
"Black Elastic Roof Paint," for roof paint, Tanner Paint & Oil Co.....	9,227
"Blue Bell," for cigars, S. Butler & Co.....	9,204
"Buckeye Brand Meats," for meats, Armacost, Riley & Co.....	9,213
"Dowler's Microbe Ointment," for ointment, F. K. Dowler.....	9,224
"Dr. Daniels' Liniment Powder," for liniment, A. C. Daniels, Inc.....	9,223
"Eskay's Cascaroil," for medicine, Smith, Klein & French Co.....	9,220
"Eskay's Neuro Phosphates," for medicine, Smith, Klein & French Co.....	9,219
"Gerhart's Cleano," for washing compounds, C. C. Gerhart.....	9,215
"Glasbrite," for a cleaning preparation, H. N. Clarke.....	9,216
"Gold Eagle," for grain, Rosenbaum Brothers	9,212
"King Sative Liniment," for liniment, P. Ray.....	9,222
"Mirafior," for cigars, Sanchez & Haya Co.	9,207
"Paulet," for insect exterminator, L. G. B. Erb.....	9,226
"Peppless Compound Tabasco Chili Sauce," for chili sauce, J. Navarro & Co.....	9,211
"Romanian Cream Skin-Food," for a toilet cream, L. D. Smith.....	9,217
"74th Regiment," for cigars, H. J. Dimond	9,205
"Shakespeare," for cigars, Sanchez & Haya Co.....	9,206
"Special Bottling Pure Rye Whiskey," for whiskey, Roxbury Liquor Dealers' Association	9,209
"Stewart's Odorless and Tasteless Castor Oil," for castor oil, Stewart Manufacturing Co.....	9,221
"Tacita," for cigars, Sanchez & Haya Co.....	9,208
"The American Puzzle Game of Advertisements and Trade Marks," for a game, H. E. Jams.....	9,200
"The Great Four-Cable Whalebone," for whips, H. M. Van Deusen.....	9,201
"The Lincoln," for whips, H. M. Van Deusen	9,203
"Ti-Ki Rawhide," for whips, H. M. Van Deusen	9,202
"Tip Top Bug Killer," for insecticide, Fleischmann Bros.....	9,225
"Whist Club," for chocolates, F. H. Dow & Company.....	9,210
"Windsor Soothing Syrup" for soothing syrup, Dinot & Delfosse.....	9,218

**PRINTS.**

"Guarding a Good Thing in Arizona," for whiskey, Brown, Forman Co.....	517
"This is Not Ours," "This is Ours," for loose leaf binders, Union File & Binder Company.....	516

A printed copy of the specification and drawing of any patent in the foregoing list, or any patent in print issued since 1863, will be furnished from this office for 10 cents, provided the name and number of the patent desired and the date be given. Address Munn & Co., 361 Broadway, New York.

Canadian patents may now be obtained by the inventors for any of the inventions named in the foregoing list. For terms and further particulars address Munn & Co., 361 Broadway, New York.

**NEW BOOKS.**

**CIVIL ENGINEERING AS APPLIED IN CONSTRUCTION.** By Leveson Francis Vernon-Harcourt, M.A., M. Inst. C.E. London, New York and Bombay: Longmans, Green & Co. 1902. 8vo. Pp. xv-624.

The name of Vernon-Harcourt is in itself a sufficient guarantee for the trustworthiness and scholarliness of the present book. The range covered is wide. After an introductory part on materials, preliminary works, foundations and roads, Vernon-Harcourt begins a description of railway, bridge and tunnel engineering.

(Continued on page 441)

# How a Jas. Boss Watch Case is made

Gold Outside Stiffening Metal Gold Inside

The Jas. Boss Stiffened Gold Watch Case is made of two layers of Solid Gold with a layer of Stiffening Metal between welded and rolled together into one solid sheet of metal. The Jas. Boss Case is a Solid Gold Case for all practical purposes. The Stiffening Metal simply adds strength and durability. The Boss Case is guaranteed for 25 years by the largest watch case makers in the world, who have been making it for a full half century. Every Boss Case has the Keystone trademark stamped inside. Ask any dealer to show you one. Write us for a booklet telling the whole story.

The Keystone Watch Case Company, Philadelphia.

By this mark  you know them

# SAVAGE

Only Hammerless Repeating Rifle in the World.

## HIGHEST DEVELOPMENT OF SPORTING RIFLES

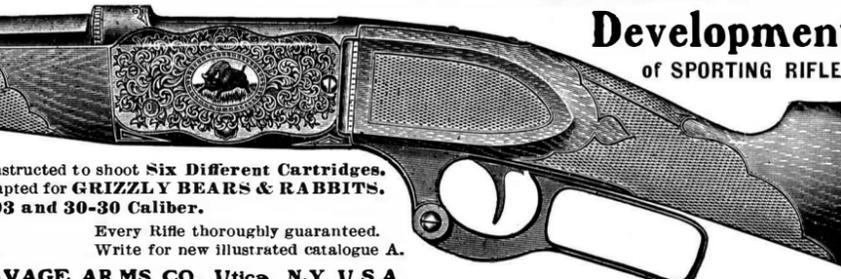

Constructed to shoot Six Different Cartridges. Adapted for GRIZZLY BEARS & RABBITS. .303 and 30-30 Caliber.

Every Rifle thoroughly guaranteed. Write for new illustrated catalogue A.

**SAVAGE ARMS CO., Utica, N.Y., U.S.A.**

Shave comfortably with a **Shumate Dollar Razor**

The successful man is carefully and regularly shaved. Don't lose time from business waiting in line in a barber shop.

Shave Yourself and Save 188 Hours and \$27.85 in a Year.

Operation painful? Razor poor? You need a Shumate. "The Razor with a character." In satisfactory use by hundreds of barbers and home users. None excel it—Replaced, and no questions if you are not pleased. \$1.00 postpaid anywhere if your dealer hasn't it. Send his name and receive free booklet: "The Razor with a Character." Contains valuable hints on shaving comfortably. **SHUMATE RAZOR CO., Dept. G, Austin, Tex., U. S. A.** St. Louis Office, 2929 Henrietta St. Chicago, 1431 Masonic Temple.

# GASOLINE ENGINES

Marine & Stationary from 1-4 to 16 H. P.

A thoroughly satisfactory engine at a moderate price. Write for catalogue.

**THE CLIFTON MOTOR WORKS,**  
233 E. Clifton Ave., Cincinnati, O.

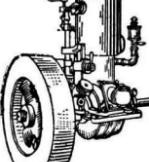

WE MAKE A SPECIALTY OF

# GREY IRON CASTINGS

FOR AUTOMOBILE WORK

**UTICA STEAM ENGINE AND BOILER WORKS**  
UTICA, N. Y.

INVENTORS AND OTHERS REQUIRING A HIGHLY NON CORROSIVE TUBING:

**"Benedict Nickel"** is what you want. Homogeneous; dense; tough. Resists Electrolysis. Send for Booklet.

**BENEDICT & BURNHAM MFG. CO.,**  
Mills & Main Office, Waterbury, Ct. New York, 233 Broadway. Boston, 172 High Street.

**EDISON WIZARD FOUNTAIN PEN and a Box of WIZARD INK ONLY 50 CTS.**

THOS. A. EDISON, JR. has invented a fountain pen that is as superior to the ordinary pen as the electric light is superior to the candle. Made on correct scientific principle, with special machinery we are enabled to sell these pens at 50 cts. each, and will present each purchaser a box of Mr. Edison's famous WIZARD INK TABLETS, which by dissolving in water make ONE PINT of the best writing fluid ever produced. Non-corrosive and chemicals cannot eradicate it. This remarkably low price is made to induce everybody to try our ink, knowing where once used no other can take its place. Agents wanted everywhere. Address **THE THOS. A. EDISON, JR. CHEMICAL CO., Dept. L, 81 Stone St., New York.**



# SELECT A PEN

Suitable for your handwriting from a sample card of 12 leading numbers for correspondence, sent postpaid on receipt of 6 cents in stamps.

**SPENCERIAN PEN CO.**  
349 Broadway, New York.



# A. W. FABER

Manufactory Established 1761.

LEAD PENCILS, COLORED PENCILS, SLATE PENCILS, WRITING SLATES, INKS, STATIONERS' RUBBER GOODS, RULERS, ARTISTS' COLORS.

78 Reade Street, New York, N. Y.  
GRAND PRIZE, Highest Award, PARIS, 1900.

# WELL DRILLING Machines

Over 70 sizes and styles, for drilling either deep or shallow wells in any kind of soil or rock. Mounted on wheels or on sills. With engines or horse powers. Strong, simple and durable. Any mechanic can operate them easily. Send for catalog.

**WILLIAMS BROS., Ithaca, N. Y.**

**JUST \$1** buys best bell outfit built. Easy to put up and an up-to-date convenience. We sell

Bells, 32c; dry batteries, 15c; push buttons, 7c; insulated wire, 30c. lb.; lamps, 35c. Write for price list.

**LIBERTY ELECTRICAL SUPPLY CO.**  
136 Liberty St., New York

**OMNIGRAPH** will teach absolutely correct in the shortest possible time at a total cost of four dollars. **FLEISCHMANN, Key and Souder** Expert operator with you all the time. Circular free.

**TRUSCOTT MARINE MOTORS.**

The simplest, most powerful, and highest speed gasoline engines of their class upon the market.

Made single, double, and triple cylinder, both two and four cycle, ranging from 1 to 40 H. P.

Catalog for the asking.

**Truscott Boat Mfg. Co.,**  
ST. JOSEPH, MICH.

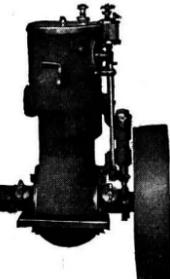

**The MEDART SYSTEM**

of supplying Boat Building Materials enables anyone ordinarily handy with tools, to build boats of the highest character at one half the boat factory's price. Freight low. Launches, Sailing Yachts and Row Boats.

Send stamp for catalog.

**FRED MEDART, 3545 DeKalb St., St. Louis, Mo.**



**FOOT-POWER LAUNCH**

with ADJUSTABLE SEATS.

Sometimes when a man starts a Gasoline Launch he says something. **Our Foot-Power Launches go without saying.** We also manufacture Gasoline Launches, Canoes (Canadian Model), St. Lawrence Skiffs. We build to any model specified. The Launches we carry in stock are the most suitable for our boat motors.

**DURAND MFG. CO., 219 South Avenue, Rochester, N. Y.**



**HENRY CAREY BAIRD & CO.,**  
INDUSTRIAL PUBLISHERS, BOOKSELLERS & IMPORTERS,  
810 Walnut St., Philadelphia, Pa., U.S.A.

Our New and Revised Catalogue of Practical and Scientific Books, 32 pages, 50c. a Catalogue of Books on Metallurgy, Mining, Prospecting, Mineralogy, Geology, Assaying, Analysis, etc.; a Catalogue of Books on Steam and the Steam Engine, Machinery, etc.; a Catalogue of Books on Sanitary Science, Gas Fitting, Plumbing, etc., and our other Catalogues and Circulars, the whole covering every branch of Science applied to the Arts, sent free and free of postage to anyone in any part of the world who will furnish his address.



**The First Step to Success**

is technical training for the work in which you propose to succeed. For ten years we have been training ambitious people to succeed.

Write to-day for circular showing how you can get the

**TECHNICAL TRAINING BY MAIL**

required by a Mechanical Engineer, Mechanical Draftsman, Steam Engineer, Electrical Engineer, Electrician, Telephone Engineer, Civil Engineer, Surveyor, Mining Engineer, Architect, Architectural Draftsman, Sign Painter, Letterer, Analytical Chemist, Ornamental Designer, Bookkeeper, Stenographer, Teacher, Cotton Mill Superintendent, Woolen Mill Superintendent, to Speak French, to Speak German, to Speak Spanish. State position you want.

International Correspondence Schools, Box 942, Scranton, Pa.

**ELECTRICAL ENGINEERING TAUGHT BY MAIL.**

Write for our Free Illustrated Book. "CAN I BECOME AN ELECTRICAL ENGINEER?"

Teach Electrical Engineering, Electric Lighting, Traction, Mechanical Engineering, Steam Engineering, Mechanical Drawing, at your home by mail. Institute indorsed by Thos. A. Edison and others.

**ELECTRICAL ENGINEER INSTITUTE,**  
Dept. A, 240-242 W. 28th St. New York.

**EARN MORE**

Study in spare time. We teach you what you need to know to earn more in your own business or another. Engineering, Drafting, Art, Architecture, Mining, Metallurgy, Business, Stenography, Journalism, Bookkeeping, etc.

Write for free catalogue 6, with full particulars.

Special Discounts Now.

**THE CONSOLIDATED SCHOOLS, 156 Fifth Ave., N. Y.**  
Including the United Correspondence Schools and others.

**ROSE POLYTECHNIC INSTITUTE**  
A College of Engineering, Mechanical, Electrical, Civil Engineering; Chemical Courses; Architecture. Extensive shops. Modernly equipped laboratories in all departments. Expenses low. 20th year. For catalog address C. L. MESS, President, Terre Haute, Ind.

**Only \$5**

**Capacity 999,999,999**

**The Locke Adder** Only Calculating Machine that Adds, Subtracts, Multiplies and Divides and sells for \$5.00 (prepaid).

**Quickly Pays for Itself.** Simple, Durable and Easily Learned. Booklet Free.

**C. E. LOCKE MFG. CO., 25 Walnut St., Kensett, Iowa.**

**ARB ROLLER BEARINGS** for all purposes.

See March 1st issue of this paper.

**A PERFECT BEARING. DURABLE. GUARANTEED.**

Send for Booklet 27.

**AMERICAN ROLLER BEARING COMPANY,**  
32 Binford Street, Boston, Mass.

**Asbesto-Metallic Packings**

SHEETING, GASKETS, TAPES and PISTON PACKINGS.

Will stand the highest steam pressure.

Write for samples and price list.

**C.W. TRAINER MFG. CO.,**  
88 Pearl St., Boston, U. S. A.

Model and Experimental Work. Small manufacturing by contract. H. B. Ward, 50 Columbia St., Newark, N. J.

**THE STEAM TURBINE; THE STEAM Engine of Maximum Simplicity and of Highest Thermal Efficiency.** By Prof. R. H. Thurston. A valuable series of articles having cuts of some of the more efficient engines of this type—the Parsons', De Laval, Dow, etc.; with exhaustive tables giving the result of tests and much general data on the subject. Contained in SUPPLEMENT Nos. 1306, 1307 and 1308. Price 10 cents each. For sale by Munn & Co. and all newsdealers

**QUIET RUNNING**

is only ONE of the advantages to be gained by using

**New Process Pinions**

instead of metal pinions. Our catalogue will tell you others. Write for it. We also make Metal Gears.

**THE NEW PROCESS RAWHIDE CO., - Syracuse, N. Y.**

which he follows by a treatment of river and canal engineering and irrigation works, dock works, maritime engineering and sanitary engineering. An admirably compiled index is not the least valuable feature of the book.

**PRINCIPLES OF WESTERN CIVILIZATION.** By Benjamin Kidd. New York: The Macmillan Company. 1902. 12mo. Pp. 538.

The author's book, "The Control of the Tropics," was a very much talked of work a few years ago, and his present contribution to a much-neglected corner of literature will be much appreciated. It shows the work of a deep thinker.

**GRADED PHYSICAL EXERCISE.** By Bertha Louise Colburn. New York: Edgar S. Werner Publishing and Supply Company. 16mo. Pp. 389. Price \$1.

This is an admirable book, dealing with a most important subject. The illustrations are excellent, and the whole scheme is a long step in advance of anything which has been done heretofore.

**THE SCENERY OF ENGLAND AND THE CAUSES TO WHICH IT IS DUE.** By the Rt. Hon. Lord Avebury. New York: The Macmillan Company. 1902. 8vo. Pp. 532. Price \$2.50.

It is rare that we find a book dealing with a geological subject published in such admirable form. The book is excellent, and deals with a subject which will interest all who care for natural science. It is elaborately illustrated by well-executed engravings and diagrams.

**Notes and Queries.**

**HINTS TO CORRESPONDENTS.**

Names and Address must accompany all letters or no attention will be paid thereto. This is for our information and not for publication. References to former articles or answers should give date of paper and page or number of question. Inquiries not answered in reasonable time should be repeated; correspondents will bear in mind that some answers require not a little research, and, though we endeavor to reply to all either by letter or in this department, each must take his turn.

Buyers wishing to purchase any article not advertised in our columns will be furnished with addresses of houses manufacturing or carrying the same.

Special Written Information on matters of personal rather than general interest cannot be expected without remuneration.

Scientific American Supplements referred to may be had at the office. Price 10 cents each.

Books referred to promptly supplied on receipt of price.

Minerals sent for examination should be distinctly marked or labeled.

(8624) W. A. H. asks: We have frequently heavy rainstorms with much lightning and very little thunder. We have again heavy rainstorms with vivid lightning and deafening crashes of thunder. Will you kindly explain the causes of these two phenomena? A. We have no especial explanation to advance why at any one time the thunder re-echoes loud and at another time it does not. The difference is perhaps due to the density of the clouds. A dense cloud would reflect the sound to the earth and confine it more than a thin cloud. When the air is much disturbed and mixed with masses of varying density near each other, sounds travel with difficulty and soon die out. This is usually the case in a thunder-storm to such an extent that the thunder is rarely heard twenty miles away from its starting point. Such considerations may help to explain the difference you mention.

(8625) C. B. H. asks: 1. How does the oil on the stormy water produce a smooth surface? Is it surface tension of the oil, or does it prevent the wind taking hold of the crest? A. Barker in his textbook on physics says: "Besides the surface tension of liquids, there is another property possessed by their surfaces, called surface viscosity, which is independent of surface tension. Owing to the much greater viscosity of the superficial film of liquids over that of the interior, this film is very hard to break. Soap solution has high surface viscosity and low surface tension, and hence is easily blown into bubbles. To a like increase of superficial viscosity and decrease of surface tension is due the stilling effect of oil upon a rough sea." 2. I am making the little electro-plating dynamo described in "Experimental Science," page 494. I would like to know: What voltage it gives at what speed? What is its internal resistance? How should it be wound to give 9 or 10 volts? What would its internal resistance then be? To what extent can the voltage and current be controlled (with as little loss of power as possible) by using a rheostat as mentioned on page 497? A. We regret that we are unable to give you answers to the questions you ask regarding the little electro-plating dynamo on page 494 of "Experimental Science." The machine has been built and has successfully plated small articles. Further we do not know. 3. Is the result worth the time and trouble in making carbon rods and plates as described on page 705, "Experimental Science"? A. It is not worth while for the amateur to make carbons. They can be bought very cheap, and cannot be made successfully without expensive machinery for pressing them before baking.

**PERFORATED METALS**  
OF EVERY DESCRIPTION AND FOR ALL USES.  
THE HARRINGTON & KING PERFORATING CO.  
225 N. UNION ST. CHICAGO, ILL. U.S.A.

**\$750**  
HYDRO-CARBON.  
20-Mile Speed.  
20 per cent. Grades.  
100-Mile Gasoline Tank.  
300-Mile Water Tank.  
900 lbs. 6 H. P. Actual.  
Write for Catalogue.

**FRIEDMAN AUTOMOBILE CO.,**  
8 E. Van Buren Street, Chicago, Ill.

This Carriage is Equipped With.....

**American Tubular Steel Wheels**  
AMERICAN TUBULAR WHEEL CO.,  
Dept. C. Pittsburg, Pa.

The "Covert Motorette"

A powerful, light and simple Automobile at a moderate price. Fully guaranteed in every respect.

Price \$600  
B. V. Covert & Co.,  
Lockport, N. Y.

**YOU WANT THE BEST SO BUY THE BARWEST Coaster Brake**

Simple. 9 Pieces. Light. Guaranteed Satisfactory.

**THE BARWEST COASTER BRAKE CO., 83 Chambers St., New York.**

**THE NEW MARSH MOTOR CYCLE**  
Model 1902. Price \$175.

A Gasoline Motor made with crank-disk, shaft in one piece, extra strong bearings, exhaust valve mechanism entirely within base, perfect lubrication, secured against dust, carburetor of the float-type which has reached the greatest perfection. This Motor Cycle is the latest acquisition in the art. Made of the best material, simple and perfect in every detail. Constructed by high skilled experts in every department and is without a peer. Full descriptive circular on application.

**MOTOR CYCLE MANUFACTURING CO., Brockton, Mass., U.S.A.**

**The Franklin Model Shop.**

Experimental work for inventors; anything in metal from a single piece to a complete working model. Apparatus for colleges. Exhibition models. Introduction samples of patented articles. Special tools for making metal novelties. Inventions perfected. Drawings and designs worked out from inventors' ideas. Send for circular.

**PARSELL & WEED,**  
129-131 West 31st Street, New York.

**WANTED.**—A Partner with money to patent small first-class invention in Canada. Will give part interest. Address A. A. S., Box 773, New York.

**Magical Apparatus.**

Grand Book Catalogue. Over 700 engravings, 25c. Parlor Tricks Catalogue, free.

**MARTINKA & CO., Mfrs., 493 Sixth Ave., New York.**

**VOLNEY W. MASON & CO.,**  
Friction Pulleys, Clutches & Elevators  
PROVIDENCE, R. I.

**WOOD ENGRAVING D.A. IRR**  
FINE LITHOGRAPHY HALF TONE. QUOTE YOUR PRICES AND SAMPLES. DUTYALON, N.Y.

**DRYING MACHINES.** S. E. WORRELL, Hannibal, Mo.

**MODEL MACHINE & Experimental WORK. PATTERN SHOP.**  
GEO. KIRKGAARD, Mechanical and Electrical Engineer, formerly with Thos. A. Edison, 514 Pearl Street, corner of Centre, New York City.

**GASMOBILE**

STANHOPE, SPECIAL, SURREY and TONNEAU BODIES.  
9, 12 and 25 H. P. SPEEDS, 25, 30 and 40 MILES.  
HIGHEST FINISH. BEST WORKMANSHIP.

**IMMEDIATE DELIVERIES**

**AUTOMOBILE COMPANY OF AMERICA**  
Marion, Jersey City, New Jersey

**The Best Thing on Wheels**  
ALL ROADS ARE ALIKE TO  
**The OLDSMOBILE**  
RUNS EVERYWHERE  
Nothing to Watch but the Road Ahead.  
Our new red catalog illustrates and describes it in detail.  
THE PRICE IS RIGHT  
OLDS MOTOR WORKS, DETROIT, MICH.

**FREDERICK PEARCE**  
216 WILLIAM STREET  
N. Y. CITY

Manufacturer of **ELECTRICAL, MECHANICAL and SCIENTIFIC APPARATUS.** Our factory is equipped with the best up-to-date machinery and tools. We make a specialty of model work for inventors, who have the benefit of assistance from our engineering dept. Further information on application.

**THE MOST MODERN AUTO**  
ELMORE AUTOMOBILES.

Practical, Durable. Efficient. Easy to control at any speed. Double cylinder motor. Smooth gliding motion. 2 models, \$800-\$1500. Get further information free.

**ELMORE MANUFACTURING CO., Clyde, O., U.S.A.**

**Bicycles Below Cost**

5000 Bicycles, overstock. For 30 days only we will sacrifice at less than actual cost.

**New 1902 Models.**

"Bellise," complete \$8.75  
"Cossack," High Grade \$9.75  
"Siberian," a Beauty \$10.75  
"Neudorf," Road Racer, no finer bicycle at any price. \$11.75

Choice of M. & W. or Record tires and best equipment on all our bicycles. Strongest guarantee.

We SHIP ON APPROVAL C.O.D. to anyone without a cent deposit. We allow 10 DAYS FREE TRIAL before purchase is binding.

500 good 2nd-hand wheels \$3 to \$8.

Do not buy a bicycle until you have written for our free catalogues with large photographic engravings and full descriptions.

**MEAD CYCLE CO., Dept. 59W, Chicago.**

**PROPOSALS.**

SEALED PROPOSALS WILL BE RECEIVED AT the office of the Light House Engineer, Tompkinsville, N. Y., until one o'clock P. M., June 27, 1902, and then opened, for the metal work and erection of Fort Wadsworth Light House, New York Harbor, N. Y. Information furnished on application to WM. T. ROSSELL, Major, Corps of Engineers, U. S. A., Engineer, 3d Dist.

**MODELS CHICAGO MODEL WORKS**  
179 E. MADISON ST. CHICAGO, ILL.  
ESTABLISHED 1867. WRITE FOR CATALOGUE OF MODEL SUPPLIES.

**HORNS FOR TALKING MACHINES**  
Crane Bros., Mfrs. Westfield, Mass.

**NOVELTIES & PATENTED ARTICLES**  
Manufactured by Contract. Punching Dies, Special Machinery. E. Konigsrow & Bro., 181 Seneca St. Cleveland, O.

**SPECIAL MANUFACTURING, SPEC. MACHINERY, MODELS, EXPERIMENTAL WORK, DIES AND STAMPING. PROMPT.**  
GLOBE MACH. & STAMPING CO. 970 HAMILTON ST. CLEVELAND, O.

**MATCH Factory Machinery.** W. E. WILLIAMS, Mfr., 217 South Clinton St., Chicago, U. S. A.

**Experimental & Model Work**  
Cir. & advice free. Wm. Gardam & Son, 45-51 Rose St., N.Y.

**STAMPING MACHINERY**  
TYPE WHEELS, MODELS & EXPERIMENTAL WORK. SMALL MACHINERY, NOVELTIES & ETC. NEW YORK STENCIL WORKS 100 NASSAU ST. N.Y.

**ICE MACHINES, Corliss Engines, Brewers' and Bottlers' Machinery.** THE VILTER MFG. CO., 389 Clinton Street, Milwaukee Wis.

**MODELS & EXPERIMENTAL WORK.**  
Inventions developed. Special Machinery.  
E. V. BAILLARD, Fox Bldg., Franklin Square, New York.

**THOROUGH INSPECTIONS**  
 AND INSURANCE AGAINST LOSS OR DAMAGE TO PROPERTY AND LOSS OF LIFE AND INJURY TO PERSONS CAUSED BY STEAM-BOILER-EXPLOSIONS  
 HARTFORD STEAM-BOILER INSPECTION AND INSURANCE CO. CONN.  
 J. M. ALLEN, PRESIDENT V. B. FRANKLIN, VICE PRESIDENT  
 J. B. PIERCE, SECRETARY F. B. ALLEN, 2<sup>ND</sup> VICE PRESIDENT  
 L. B. BRAINERD, TREAS. L. F. MIDDLEBROOK, ASST. SECY.

**WINTON TOURING CAR**  
 Both Wintons entered in the Long Island 100-mile (non-stop) Endurance Contest made 100 per cent. exhibitions. To each was awarded a Blue Ribbon.

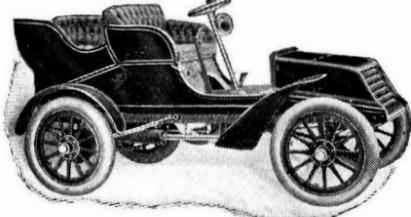

Touring Car—Tonneau Detachable.  
 Price Complete, \$2,000  
 The Winton Touring Car (Class D—less than 2000 lbs.) captured first honors and the silver cup award in the hill-climbing contest. Get our catalog. The Winton Motor Carriage Co., Cleveland, O. U.S.A. Branches and agencies throughout the country.

**THE VICTOR Steam Pumps**

Size, 9 inches by 3 inches, weight, 4½ pounds. Capacity of Air Pump, 80 pounds pressure on tanks or tires.  
 Capacity of Water Pump, 3 gallons per minute against 200 pounds boiler pressure.  
 PRICE, \$30 00 EACH.  
 These pumps have been adopted by the Locomobile Co., the Mobile Co., and other leading manufacturers of steam carriages.  
**OVERMAN AUTOMOBILE CO.,**  
 7 East 42d Street, New York.  
 Send for Illustrated Circular.

**DO YOU WANT A MOTOR THAT GIVES NO TROUBLE?**

TRY THE IMPORTED **KELECOM MOTORS**  
 Single and Double Cylinder Water Cooled  
 They have been thoroughly tried and found true. Went through the 100-Mile Long Island test without a stop.  
 6, 7, 8, 9, 11 H. P. Single Cylinder Double Cylinder  
 The price is extremely low. The results have been proved.  
 Sole Agent **A. H. FUNKE, 101 Duane Street, New York.**

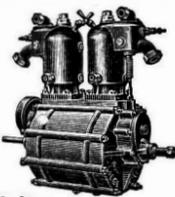

If it isn't an Eastman, it isn't a Kodak

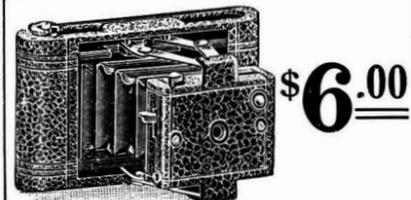

**A new folding KODAK**

for the pocket—almost for the vest pocket, at six dollars. Makes pictures 1½ x 2½ inches, loads in daylight, has a fine meniscus lens, brilliant finder, automatic shutter—in fact, has the "Kodak quality" all the way through.

No. 0 Folding Pocket Kodak, for pictures 1½ x 2½ inches, \$6.00  
 Transparent Film Cartridge, 12 exposures, 1½ x 2½, .25  
 Do., 6 exposures, .15

**EASTMAN KODAK CO.**  
 Rochester, N. Y.  
 Catalogue free at the dealers or by mail.  
 \$4,000,000 in prizes for Kodak and Brownie Pictures.

**RIVETT LATHE**  
 No up-to-date manufacturer can afford to do without it.  
**GOLD MEDAL**  
 AT THE PAN-AMERICAN EXPOSITION.  
 Send for Catalog.  
**Faneuil Watch Tool Company,**  
 BRIGHTON, BOSTON, MASS., U. S. A.

**Basket Shares Advancing to Par**

Notice is hereby given that upon completion of negotiations now in progress, shares of the Mergenthaler-Horton Basket Machine Co. will be advanced to par. The present selling price of the shares is

**75 CENTS**  
 (Par value \$1.00, full paid and non-assessable.)

There will be no intermediate price between 75 cents and par, as the present negotiations, now nearly completed, will equip the company at once with a great mill property surrounded by inexhaustible supplies of lumber at inconceivably low prices. The property includes over two miles of docks on one of the Great Lakes, with ideal facilities for cheapest water transportation of baskets to every fruit-growing district of New York, Michigan, Ohio, New Jersey, Delaware, Maryland, New England, Indiana and Illinois.

**200 MACHINES,**

Orders for which have been placed, will at once be installed in this great property, giving the company an equipment sufficient to turn out 180 million grape baskets and 600 million quart berry baskets per year, a total volume of business upon which the actual net profits exceed

**2 1-2 MILLIONS OF DOLLARS**  
 Or over 25 per cent. on the Company's entire capital.

This statement is given at this time in order that those who are considering investment in the shares of the Company may be fully and fairly informed and may, if they act promptly, secure shares at

**75 CENTS EACH,**

which shares will in a very short time be worth many times this price, because the Company has actual demand for the full output of this immense factory at prices which will yield the profit stated.

The time to decide this matter is NOW, and to assist those who wish to subscribe and who are not fully provided with the money, the Directors have authorized the acceptance of

**One-Quarter in Cash with Subscription**

and balance in three equal monthly installments. Not less than fifty and not more than five thousand shares will be accepted in a single subscription, and the right is reserved to reject any subscription. Checks should be drawn to the order of Charles R. Barlow, Treasurer.

N. B. The automatic basket making machines of the Company are on exhibition, making baskets in Boston at 179 Tremont Street, in Chicago at 118 Monroe Street, and in Philadelphia at 812 Chestnut Street, and they will at once be placed upon exhibition also in Pittsburg, Buffalo and St. Louis.

**The MERGENTHALER-HORTON BASKET MACHINE CO.**  
 Executive Offices, 287 BROADWAY, NEW YORK.

**Solicitors**  
**FLETCHER, McCUTCHEON & BROWN**  
 76 William Street, New York.

**Transfer Agents**  
**CORPORATION TRUST COMPANY**  
 135 Broadway, New York.

**Orient Motor Cycle.**



PRICE \$250.00  
 Fitted with the New Orient 3 H. P. Motor. Speed over 40 Miles per hour. The Most Powerful Motor Bicycle in the World. Write for Particulars. Agents Wanted.  
**WALTHAM MFG. CO., Waltham, Mass.**

**JESSOP'S STEEL** THE VERY BEST  
 FOR TOOLS, SAWS, ETC.  
 WM. JESSOP & SONS, L<sup>TD</sup> 91 JOHN ST. NEW YORK

**CRUDE ASBESTOS**  
 DIRECT FROM MINES  
**PREPARED ASBESTOS FIBRE** for Manufacturers use  
**R. H. MARTIN,**  
 OFFICE, ST. PAUL BUILDING  
 220 B'way, New York.

**CHARTER ENGINE**

**USED ANY PLACE BY ANY ONE FOR ANY PURPOSE**  
 Stationaries, Portables, Sawing Outfits, Hoisters, Engines and Pumps.  
 Fuel—Gasoline, Gas, Distillate.  
 Send for Illustrated Catalogue and Testimonials, and State Your Power Needs.  
**CHARTER GAS ENGINE CO., Box 148, STERLING, ILL.**

**RUST** ON GUNS TOOLS & CYCLES PREVENTED  
 BY **MANNOCITIN**  
 CHICAGO ILL. U.S.A.

**NEW ENGLAND WATCHES**

have a world-wide reputation gained by results as accurate timekeepers. We make all sizes and styles. We sell only complete watches. Catalogs sent on request.  
**THE NEW ENGLAND WATCH CO.**  
 37 & 39 Maiden Lane New York 181 Wabash Ave., Chicago.  
 Claus Spreckels Building, San Francisco.

**Century CHAINLESS AUTOMOBILES**



Have many exclusive features—Flexible Frame, One Hand Control, Bevel Gear Drive—No Chain, Engine and Transmission running in oil, Large Fuel and Water Capacity, Instantaneous Foot Reverse, and a Burner with a pilot light that doesn't blow out.  
 No. 1, Steam Runabout, Price \$900  
 Blue Ribbon Winner Long Island Endurance Contest. Record of 100 per cent.  
**Century Motor Vehicle Co., Syracuse, N. Y., U. S. A.**  
 New Catalogue Ready.

**PRESIDENT Suspenders**

are made to make men comfortable at work and at play.  
 Every pair guaranteed. Trimmings can not rust. Look for "President" on the buckles. New model now ready for men of heavy work; also small size for youths. Price 50c. If you have any trouble in getting the genuine, we will send you a pair of the latest design, post-paid, on receipt of price.  
**C. A. EDGARTON MFG. CO.,**  
 Shirley, Mass.  
 Box 222

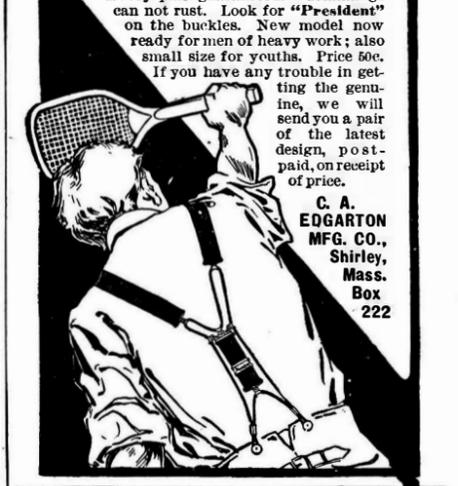

All varieties at lowest prices. Best Rail, Track and Wagon or Stock Scales. Also 1000 useful articles, including Sewing Machines, Bicycles, Tools, etc. Save Money. Lists Free. **CHICAGO SCALE CO., Chicago, Ill.**

**ACCOUNTANTS** who use the **Comptometer** have no trouble with their trial balance. Has it ever occurred to you that by getting one you might save lots of time, avoid mistakes and not ruin your nerves? Write for Pamphlet.  
**FELT & TARRANT MFG CO.**  
 52-56 ILLINOIS ST., CHICAGO.

**STEWART'S WONDER**  
 The Exponent of Highest Art in **ACETYLENE BURNERS** Sample 25c. in stamps. Ask for catalogue C. **STATE LINE MFG. CO., Chattanooga, Tenn., U. S. A.**  
 107 Chambers St., New York.

THE STANDARD ACETYLENE LAMPS FOR VEHICLES OF ALL SORTS FOR YEARS HAVE BEEN

**SOLAR LAMPS**



From the time of the introduction of Acetylene Gas there has been only one lamp that would stand every test—The Solar. The acme of Solar perfection is the new French Auto Headlight illustrated here. Our catalogue tells all about Solar Lamps of all kinds.  
 SEND FOR IT.  
**BADGER BRASS MFG. CO., - - Kenosha, Wis.**

**DO YOU USE GRINDSTONES?**  
 If so we can supply you. All sizes mounted and unmounted, always kept in stock. Remember, we make a specialty of selecting stones for all special purposes. Ask for catalogue.  
**THE CLEVELAND STONE CO.**  
 2d Floor, Wilshire, Cleveland, O.

**WANTED REPRESENTATIVE**

Business men wanted for cities of 10,000 and over to open exhibition parlors or stores for the display and sale of our  
**"KEYLESS CLOCK,"**  
 Just being introduced to the public. Clocks are self-winding and run a year without attention; no one will buy key wound clocks when they see and have an opportunity to buy the latest thing; full line of samples now ready; parties having \$500 and upward to invest and ability to manage can secure agency for cities not already taken; parties making arrangements now will have name appear in our advertisements. Address The United States Clock Co., executive offices, No. 405 Broome Street, New York.

**Big and Little—Heavy and Light**  
**The HARTFORD SINGLE TUBE and DUNLOP DOUBLE TUBE Tires**  
 Stand foremost for Uniform Quality, Honest Construction and Durability. That each is the most serviceable tire of its class is universally acknowledged by those buyers who desire The Best regardless of cost, and thus consider the question of their needs intelligently. Let us advise you regarding the proper size and weight of tire best adapted to your requirements. Branches in principal cities.  
**The HARTFORD RUBBER WORKS COMPANY**  
 HARTFORD CONN.  
 (Users of SOLID RUBBER TIRES may rest assured that our reputation as makers of only high-class goods will be carefully sustained in connection with this product)  
 These are the only tools you will need  
**SINGLE TUBE**