

SPACE

Inside Primitive
Meteorites

HUMAN EVOLUTION

A Puzzling
Ancestry

MEDICINE

The Myth about
Antioxidants

SCIENTIFIC AMERICAN

ScientificAmerican.com

FEBRUARY 2013

Building Blocks of Memory

How sets of cells
encode concepts in the brain



C-MAX says **Ha.**
C-MAX says **Wheeee.**
C-MAX gets 54 more net horsepower than the **Prius v**,
a hybrid that C-MAX also beats in **MPG.***

Say hi to the all-new 5-passenger 2013 47-combined-MPG

C-MAX HYBRID

ford.com



Go Further

*EPA-estimated 47 city/47 hwy/47 combined mpg. Actual mileage will vary.



Exactly how the brain encodes memories has long been one of science's big mysteries. Research shows that small sets of neurons deep within the brain are capable of being activated by the memory of someone familiar—your grandmother, say. This neural architecture makes the brain more efficient than if each memory were spread among many millions of cells. Image by Jean-François Podevin.

SCIENTIFIC AMERICAN

February 2013 Volume 308, Number 2



68

FEATURES

NEUROSCIENCE

30 **Brain Cells for Grandmother**

Each person or thing in our everyday life may exist in our brain with its own corresponding set of neurons assigned to it. *By Rodrigo Quián Quiroga, Itzhak Fried and Christof Koch*

SPACE

36 **Secrets of Primitive Meteorites**

Microscopic analyses of the oldest rocks in the solar system hint at what our corner of space was like shortly before the planets formed. *By Alan E. Rubin*

HUMAN EVOLUTION

42 **Shattered Ancestry**

Recent fossil finds have made identifying our ancient progenitors even more difficult. *By Katherine Harmon*

CLIMATE

50 **Rethinking the Gulf Stream**

The warm flow of ocean water from the Gulf of Mexico keeps European winters mild, right? Maybe not. *By Stephen C. Riser and M. Susan Lozier*

ENGINEERING

56 **The Battery-Powered Bullet**

Few gas-powered cars have surpassed 400 miles per hour. Now an industrious group of students plans to break this barrier in an electric vehicle. *By Gregory Mone*

MEDICINE

62 **The Myth of Antioxidants**

Do vitamins keep us young? Growing evidence has cast doubt on the popular belief that oxidative damage causes aging. *By Melinda Wenner Moyer*

CITIZEN SCIENCE

68 **Data on Wings**

A modest effort to enlist amateur bird-watchers in the cause of ornithology has produced a trove of valuable data and helped to set the standard for “citizen science” to grow into a field in its own right. *Plus: How you can become a citizen scientist. By Hillary Rosner*

NORWEGIAN FJORDS, JULY 5–15, 2013



For information on more trips like this, please log onto www.ScientificAmerican.com/Travel



Are you restless? Seeking new science horizons? Slake your thirst for the latest in science, Viking style, on Bright Horizons 17 cruise conference aboard Celebrity Cruises' Infinity, round-trip Harwich, England to the Norwegian fjords, July 5–15, 2013. Pack your curiosity and join a floating community of keen minds and quick wits voyaging into a landscape of epic beauty.

Top off your fund of knowledge about chemical bonds. Venture into the weird, weird world of quantum mechanics. Go deep into the neurobiology of stress and aggression. Site the Vikings in a context of ingenuity and adaptation. As we travel, you can visit the UNESCO World Heritage sites of Geiranger Fjord and Bryggen, enjoy scenic and noteworthy rail trips, and view glaciers and waterfalls.

Powered by the midnight sun, immerse yourself in essential Norway. Bring a friend and relax amidst scenic beauty from sky to fjord. Refresh the spirit, share downtime with near and dear, savor Nordic cuisine. Absorb new views and innovative thinking from the experts while enjoying the delights of Scandinavia. Join the fun on Bright Horizons 17. Visit www.InsightCruises.com/SciAm-17, contact conciierge@insightcruises.com, or call (650) 787-5665.

Cruise prices vary from \$2,169 for an Interior State-room to \$7,499 for a Royal Suite, per person. For those attending our Program, there is a \$1,575 fee. Port charges are \$235. Government taxes and an Insight Cruises service fee are \$215 per person. Gratuities are \$150 per person. Program subject to change.



Neurobiology

Speaker: Robert Sapolsky, Ph.D.

The Biology of Memory

Consider the biology of memory. We'll start with the neurobiology of different types of memory, from the pertinent regions of the brain down to the pertinent molecules and genes. Learn about memory's impressive features, wild inaccuracies, and failings in neurological diseases. Examine individual differences in memory skills and find out how to improve your own memory capacities.

Sushi and Middle Age

When was the last time you tried a really different, strange type of food, explored the work of a new composer, or made a substantial change in appearance? As we age, we

get less interested in novelty and increasingly crave the familiar. Examine the neurobiology and psychology underlying this age-related effect.

Humans: Are We Just Another Primate? Are We Just a Bunch of Neurons?

Dr. Sapolsky both does neurobiology research in the lab and research on wild baboons in East Africa. He'll consider human nature from these two perspectives. Are we just another primate on a continuum with all the others, or are we intrinsically special? Find out a biologist's answer.

The Biology of Aggression and Violence

Examine the biology of violence, dealing with a single fact that makes this one of the most complicated subjects in behavioral biology — we don't hate violence, just violence in the wrong context. Looking at neurobiology, Us/Them dichotomies, hormones, evolutionary biology, and game theory, put the phenomenon of violence in a scientific context.



Hampton Court and Windsor Castle (July 2)

Join us visiting two timeless treasures in a day designed to bring British history to life. Enhance your knowledge of Britain's history with an idyllic day trip to Windsor Castle (left) and Hampton Court Palace. They are related yet differing demonstrations of British monarchy, nationhood, and domesticity.

It's good to be Queen, and the evidence is all about you at 1,000 year old Windsor Castle. Rubens, Rembrandt, and a remarkable collection of fine art envelope you in history. Go behind the scenes at the legendary seat of the House of Windsor.

Hampton Court (also known as King Henry VIII's summer palace) is a place of royal passions and competing interests. Pomp and consequence, subterfuge and service inform the history of the palace. Our visit will put the juxtaposed Tudor and Baroque architecture, larger than life personalities, exquisite Chapel Royal, and magnificent gardens in historical context for you.



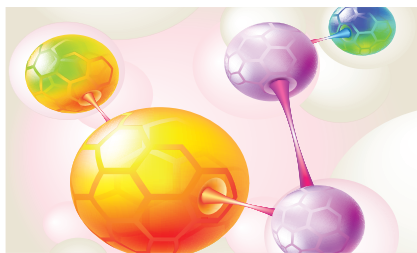

Chemistry

Speaker: Robert Hazen, Ph.D.

Genesis: The Scientific Quest for Life's Origins — Is life's origin an inevitable process throughout the cosmos, or is it an improbable accident, restricted to a few planets (or only one)? How does a lifeless geochemical world of oceans, atmosphere, and rocks transform into a living planet? Find out how scientists use experimental and theoretical frameworks to deduce the origin of life.

The Diamond Makers

Diamond forms deep in Earth when carbon experiences searing heat and crushing pressure. Decades ago General Electric scientists learned how to mimic those extreme conditions of Earth's interior in the laboratory to make synthetic diamonds. Learn the human drama and technological advances involved in producing this coveted gem and industrial tool from carbon-rich substances.

The Story of Earth: How the Geosphere and Biosphere Co-evolved

Earth is a planet of frequent, extravagant change. Its near-surface environment has transformed over and over again across 4.5 billion years of history. Learn about the work of Dr. Hazen and colleagues that suggests that Earth's living and nonliving spheres have co-evolved over the past four billion years.

Chemical Bonding — The solid, liquid, and gaseous materials around us depend on the specific elements involved and the chemical bonds that hold those atoms together. By looking at the nature and significance of ionic, metallic, and covalent bonds you'll gain a new understanding of the workings of the world around you.

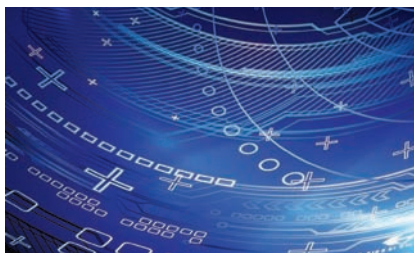

Quantum Physics

Speaker: Benjamin Schumacher, Ph.D.

Private Lives of Quantum Particles

Quantum systems can exhibit all sorts of bizarre behavior. But many of these phenomena can only be observed under conditions of the strictest privacy, where systems are "informationally isolated" from the world. These are not accidental features of quantum theory. They are inescapable facts about the microscopic world: Quantum physics is what happens when nobody is looking.

2π Is Not Zero (But 4π Is) — If you rotate any geometrical shape by 360 degrees (2π radians) about any axis, you will end up with exactly the same shape. But this fact, seemingly obvious, is not true for quantum particles with spin. Learn how a rotation by 2π makes a big difference, and how it all comes down to a simple minus sign — probably the most important minus sign in all of physics. Enjoy quantum fun, demystified by Dr. Schumacher.

The Physics of Impossible Things

Physicists find it surprising useful to ponder the impossible. Using the laws of nature, assess the possibility of science fiction's favorite phenomena and explore seemingly impossible things, which while odd, are possible. Venture into the study of impossible things and come away with an affirmation of the consistent logic of nature, and renewed wonder at real phenomena.

The Force That Isn't a Force — What makes a rubber band elastic? It's entropy, the microscopic disorder of its molecules. Now, entropy may provide a clue to the most familiar and mysterious of the basic forces of nature: gravity. Explore the link between entropy and gravity, and gain fascinating and unexpected insights of contemporary theoretical physics.



Archaeology

Speaker: Kenneth Harl, Ph.D.

From Old Europe to Roman Provinces

Explore the prehistoric foundations of Scandinavia and the Viking Age from ca. 3000 B.C. to 400 A.D. From Megalithic cultures to the arrival of Indo-Europeans, to Northern Bronze Age innovations and Celtic and Roman contributions, learn the unique environmental, cultural, and social factors that create a context for the Vikings.

Great Halls and Market Towns in Viking Age Scandinavia — Using archaeology and literary sources (especially saga and Eddas), learn how the "great halls" emerged as the main focus of Scandinavia civilization. Find out how the development of towns facilitated trade and were vital for the transformation and technological advance of Scandinavian society.

Ships and Ship Building in the Viking Age — European history records the effectiveness of the fearsome Viking longship; find out the features and technologies that made it so. Based on archaeological finds, learn about the multi-millennial evolution of the longship, from linden to oak, dugout to mast and sail. Gain an appreciation for the form and function, as well as the wider implications of Norse naval mastery for three hundred years.

Warfare in the Viking Age — The Viking's applied technologies led to three centuries of robust military and economic power for Scandinavia. Discover what factors made the Vikings accomplished warriors and learn what archaeological finds tell us about Viking exploration, settlement, and development of kingdoms.

SCIENTIFIC AMERICAN

Travel

HIGHLIGHTS

NORWEGIAN FJORDS
JULY 5-15, 2013



The Royal Observatory and the Churchill War Room/Museum (July 4)

Take the road less traveled in London, visiting two less well known gems of the City, both uniquely fascinating and inspiring.

Courage, duty, shared sacrifice, and conviction are the foundation of the Churchill

Cabinet War Rooms. Hidden in plain sight in the heart of London, a scant 600 miles from Berlin. Step back in time and discover how Churchill and Britain's government functioned in secrecy in these quarters, from the Blitz to VE Day. The furnishings, maps, and ephemera are as they were on VE day, May 8, 1945. Hear the stories and imag-

ine life under bombardment in the simple and inspiring environment of the Cabinet War Rooms.

Are you the precise type? Are you a fan of Google maps or GPS? Or Cutty Sark? Join us on a tour of maritime Greenwich, where our prime objective is visiting the Royal Observatory, Greenwich, home of the Prime Meridian of the World and Greenwich Mean Time. Stroll a deeply historic corner of London significant in local, national, and international culture. See



the Royal Observatory, the National Maritime Museum, the tea clipper Cutty Sark, and the Royal Naval College. Master the lingo of time — UT0, UT1, UTC, and GMT. Stand astride two hemispheres on the Prime Meridian, a moment sure to be recorded on your timeline.



Stonehenge and Bath (July 3)

Pass a day on the Salisbury Plains and Somerset Hills, absorbing the history of two spots with ancient cultural roots.

Mute, mysterious, and megalithic, Stonehenge calls to us across the millennia. We'll respond, and walk the site in its details. Learn the significant geography, the archaeological and astronomical background, and the key stone names. But those are just the facts — the memories and true meaning of Stonehenge will be up to you.

Bath beckons the seasoned traveler. People are drawn to Bath to see its honey-colored Bath limestone buildings, and to explore its 2,000 year history as a place of relaxation and restoration. Plumb the details and nuances of Bath's fusion of architecture, culture, and history in a city with many echoes of and homages to the ancient world, while embodying the Georgian worldview.

For more info please call 650-787-5665 or log on to ScientificAmerican.com/Travel

SCIENTIFIC AMERICAN

DEPARTMENTS

6 From the Editor

8 Letters

12 Science Agenda

Regulations for prenatal genome sequencing must be put in place soon. *By the Editors*

13 Forum

A separate Internet for rich and poor. *By Michael Fertik*

14 Advances

Toll of the tar sands. Moons' origins. Forests vs. meadows. Katydid and human ears are alike. Inside Einstein's brain.

27 The Science of Health

Some athletes' enthusiasm for unapproved stem cell treatments outpaces the evidence. *By Deborah Franklin*

29 TechnoFiles

It's time for digital designers to stop imitating the physical world. *By David Pogue*

74 Recommended

Living weird. Animals' emotions. Hunting for Nazi submarines. Laying down Manhattan's grid. *By Anna Kuchment*

76 Skeptic

Politics distorts science on both ends of the spectrum. *By Michael Shermer*

78 Anti Gravity

Free us from far-fetched fears. *By Steve Mirsky*

80 50, 100 & 150 Years Ago

82 Graphic Science

The trouble with global risks. *By Fred Guteri*

ON THE WEB

Why We Love Doomsday Predictions

If you're reading this, the purported Mayan apocalypse failed to arrive in 2012. To mark the nonoccasion, we tour some of the more memorable doomsday scenarios and investigate the factors that contribute to their appeal.

Go to www.ScientificAmerican.com/feb2013/doomsday



14



27



74

Scientific American (ISSN 0036-8733), Volume 308, Number 2, February 2013, published monthly by Scientific American, a division of Nature America, Inc., 75 Varick Street, 9th Floor, New York, N.Y. 10013-1917. Periodicals postage paid at New York, N.Y., and at additional mailing offices. Canada Post International Publications Mail (Canadian Distribution) Sales Agreement No. 40012504. Canadian BN No. 127387652RT; TVQ1218059275 TQ0001. Publication Mail Agreement #40012504. Return undeliverable mail to Scientific American, P.O. Box 819, Stn Main, Markham, ON L3P 8A2. **Individual Subscription rates:** 1 year \$39.97 (USD), Canada \$49.97 (USD), International \$61 (USD). **Institutional Subscription rates:** Schools and Public Libraries: 1 year \$72 (USD), Canada \$77 (USD), International \$84 (USD), Businesses and Colleges/Universities: 1 year \$330 (USD), Canada \$335 (USD), International \$342 (USD). Postmaster: Send address changes to Scientific American, Box 3187, Harlan, Iowa 51537. **Reprints available:** write Reprint Department, Scientific American, 75 Varick Street, 9th Floor, New York, N.Y. 10013-1917; fax: 646-563-7138; reprints@SciAm.com. **Subscription inquiries:** U.S. and Canada (800) 333-1199; other (515) 248-7684. Send e-mail to sacust@sci.com. Printed in U.S.A. Copyright © 2013 by Scientific American, a division of Nature America, Inc. All rights reserved.





MILLENNIUM
TECHNOLOGY
PRIZE

The search for the 2014 MILLENNIUM TECHNOLOGY PRIZE LAUREATES starts here!

Nominate your candidate for the prize that recognises groundbreaking technologies and scientific developments and stimulates further cutting edge research and development, with a prize pot of at least €1 million.

To nominate candidates visit www.millenniumprize.fi/cfn

IN 2012 THE WINNERS OF THE BIENNIAL PRIZE WERE

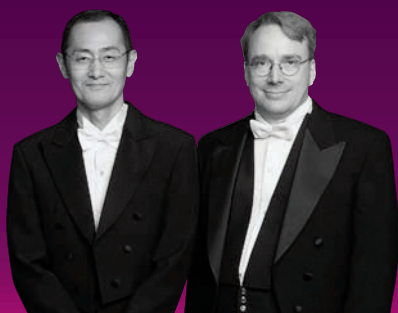

SHINYA YAMANAKA (left)
for the stem cell technology which
also won him the Nobel Prize in
Physiology or Medicine 2012

LINUS TORVALDS (right)
for creating the world's leading
open source operating system
Linux

AWARDED BY

TAF

TECHNOLOGY
ACADEMY
FINLAND

STRATEGIC PARTNER

A! Aalto University

Mariette DiChristina is editor in chief of *Scientific American*. Follow her on Twitter @mdichristina



Minds in Motion

IT'S OFTEN SURPRISING TO ME HOW PROFOUND INSIGHTS CAN arise from simple questions. Here's one: How does the brain capture a single concept? Naturally, our minds make use of networks of neurons—but are they sparse or distributed over large populations of cells? Researchers are exploring and debating that question and will likely be doing so for some time.

There is now evidence that each of us has sets of “concept cells” that know all the 10,000 or so concepts that a typical person remembers. As the cover story, “Brain Cells for Grandmother,” by neuroscientists Rodrigo Quiroga, Itzhak Fried and Christof Koch, explains, these groups of neurons not only recognize an image of, say, your grandmother, they also react to her written name and to things that are closely related to her. The concept cells appear to link perception to memory, give representation of meaningful concepts and form the building blocks of memory. Turn to page 30 for the article.

A different kind of tangible connection is at work in “Secrets of Primitive Meteorites,” by geochemist Alan

E. Rubin, starting on page 36. Unlike astronomers, who can only see celestial bodies from a great distance, Rubin says he derives emotional and intellectual satisfaction from being able to hold and probe the objects of his research: ancient asteroidal fragments called chondrites. These space rocks bring with them to Earth clues about their origins in the solar system, where our concept cells can properly appreciate them. ■

Innovation at Work

As everybody knows, the innovations that come from research do not occur in a vacuum. Likewise, *SCIENTIFIC AMERICAN* enjoys numerous partnerships, which help us connect to new audiences about science. I thought I would highlight three kickoffs for you.

First, this issue marks the start of several upcoming collaborations with the World Economic Forum. In *Graphic Science*, on page 80, you will see the thought-provoking results of its latest *Global Risks Report*. And on page 13, Michael Fertik of Reputation.com writes in our Forum column about how online personalization has a dark side: it has created an Internet that differs for rich and poor. As this issue arrives, I will be at the annual meeting in Davos, Switzerland, to run some sessions and gather further information.

Second, I attended the ribbon cutting for the new, \$64-million Max Planck Florida Institute for Neuroscience, which joins the nearby Scripps Florida on the Florida Atlantic University campus to form a new center for science in the Sunshine State.

Third, later in January begins the 2013 Google Science Fair, which includes the competition for the *SCIENTIFIC AMERICAN*-sponsored \$50,000 Science in Action Award. As I have done for the past two years, I will serve as a judge for this global competition for students ages 13 through 18. —M.D.

BOARD OF ADVISERS

Leslie C. Aiello
President, Wenner-Gren Foundation for Anthropological Research

Roger Bingham
Co-Founder and Director, The Science Network

G. Steven Burrill
CEO, Burrill & Company

Arthur Caplan
Director, Division of Medical Ethics, Department of Population Health, NYU Langone Medical Center

George M. Church
Director, Center for Computational Genetics, Harvard Medical School

Rita Colwell
Distinguished University Professor, University of Maryland College Park and Johns Hopkins Bloomberg School of Public Health

Drew Endy
Professor of Bioengineering, Stanford University

Ed Felten
Director, Center for Information Technology Policy, Princeton University

Kaigham J. Gabriel
Corporate Vice President, Motorola Mobility, and Deputy, ATAP

Michael S. Gazzaniga
Director, Sage Center for the Study of Mind, University of California, Santa Barbara

David J. Gross
Professor of Physics and Permanent Member, Kavli Institute for Theoretical Physics, University of California, Santa Barbara (Nobel Prize in Physics, 2004)

Lene Vestergaard Hau
Mallinckrodt Professor of Physics and of Applied Physics, Harvard University

Danny Hillis
Co-chairman, Applied Minds, LLC

Daniel M. Kammen
Class of 1935 Distinguished Professor of Energy, Energy and Resources Group, and Director, Renewable and Appropriate Energy Laboratory, University of California, Berkeley

Vinod Khosla
Partner, Khosla Ventures

Christof Koch
CSO, Allen Institute for Brain Science, and Lois and Victor Troendle Professor of Cognitive and Behavioral Biology, California Institute of Technology

Lawrence M. Krauss
Director, Origins Initiative, Arizona State University

Morten L. Kringlebach
Director, Hedonia: TrygFonden Research Group, University of Oxford and University of Aarhus

Steven Kyle
Professor of Applied Economics and Management, Cornell University

Robert S. Langer
David H. Koch Institute Professor, Department of Chemical Engineering, M.I.T.

Lawrence Lessig
Professor, Harvard Law School

Ernest J. Moniz
Cecil and Ida Green Distinguished Professor, M.I.T.

John P. Moore
Professor of Microbiology and Immunology, Weill Medical College of Cornell University

M. Granger Morgan
Professor and Head of Engineering and Public Policy, Carnegie Mellon University

Miguel Nicolelis
Co-director, Center for Neuroengineering, Duke University

Martin A. Nowak
Director, Program for Evolutionary Dynamics, and Professor of Biology and of Mathematics, Harvard University

Robert Palazzo
Professor of Biology, Rensselaer Polytechnic Institute

Carolyn Porco
Leader, Cassini Imaging Science Team, and Director, CICLOPS, Space Science Institute

Vilayanur S. Ramachandran
Director, Center for Brain and Cognition, University of California, San Diego

Lisa Randall
Professor of Physics, Harvard University

Martin Rees
Astronomer Royal and Professor of Cosmology and Astrophysics, Institute of Astronomy, University of Cambridge

John Reganold
Regents Professor of Soil Science and Agroecology, Washington State University

Jeffrey D. Sachs
Director, The Earth Institute, Columbia University

Eugenie Scott
Executive Director, National Center for Science Education

Terry Sejnowski
Professor and Laboratory Head of Computational Neurobiology Laboratory, Salk Institute for Biological Studies

Michael Shermer
Publisher, *Skeptic* magazine

Michael Snyder
Professor of Genetics, Stanford University School of Medicine

Michael E. Webb
Co-director, Clean Energy Incubator, and Associate Professor, Department of Mechanical Engineering, University of Texas at Austin

Steven Weinberg
Director, Theory Research Group, Department of Physics, University of Texas at Austin (Nobel Prize in Physics, 1979)

George M. Whitesides
Professor of Chemistry and Chemical Biology, Harvard University

Nathan Wolfe
Director, Global Viral Forecasting Initiative

R. James Woolsey
Chairman, Foundation for the Defense of Democracies, and Venture Partner, Lux Capital Management

Anton Zeilinger
Professor of Quantum Optics, Quantum Nanophysics, Quantum Information, University of Vienna

Jonathan Zittrain
Professor of Law and of Computer Science, Harvard University

**Advancing fusion technology:
to extract endless clean energy
from ordinary seawater...**

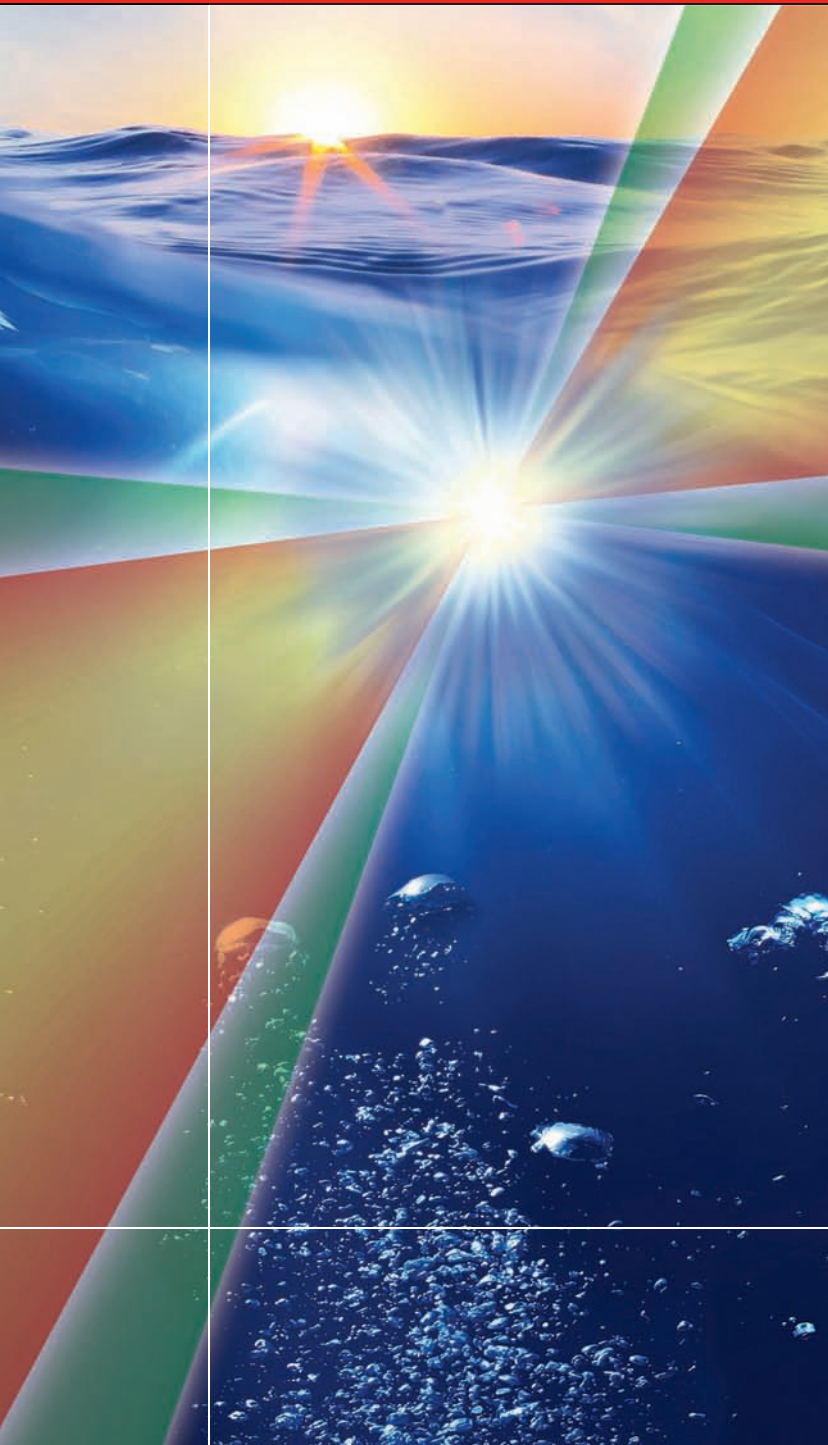

A breakthrough in laser fusion

Nuclear fusion of deuterium and tritium is a very attractive energy source. It's clean, safe and virtually inexhaustible, since both isotopes can come from seawater. But the technology to enable fusion power plants still remains elusive...

So Hamamatsu

has been developing

more powerful lasers, more

advanced fusion

targets and higher

performance laser

fusion diagnostics.

Using an elegantly

simple *direct fast ignition* scheme, Hamamatsu

works with inventor Professor Y. Kitagawa of

The Graduate School for the Creation of New

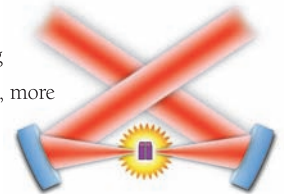

From two sides, laser beams implode a fuel pellet to high density and then immediately superheat it, triggering nuclear fusion and release of heat.

**Hamamatsu is opening
the new frontiers
of Light * * ***

Photonics Industries. In this concept, laser beams strike a tiny fuel pellet from opposite directions, imploding it to extreme density. Two subsequent



Artist's conception of a new laser fusion power plant.

beams trace the same path to superheat the compressed fuel and trigger fusion of nuclei.

This demonstrates the world's first generation of fusion neutrons

from direct heating by an ultra-high intensity laser. It helps confirm the viability of small fusion power plants and enlightens future energy development.

Laser fusion research—it's Hamamatsu's way of helping provide plentiful energy for our world.

<http://jp.hamamatsu.com/en/rd/publication/>

HAMAMATSU

PHOTON IS OUR BUSINESS

The fusion of deuterium and tritium nuclei, triggered by high-intensity lasers, can release tremendous amounts of heat to boil water and drive turbines to generate electric power. Seawater can be a limitless source of the hydrogen isotopes deuterium and tritium.



October 2012

RESEARCH AND INCOME

In “The Other 1 Percent,” Paula Stephan provides no evidence that income inequality positively affects scientific output, as she argues. As she mentions, the U.S. pours more than 0.3 percent of its (very large) GDP into science, and there are 100 other reasons—social, economic and historical—for high U.S. publication rates. The only evidential statement made, about Saudi Arabian output, goes against the article’s main point (illustrating that high pay has not correlated with top research rankings), but even here it is difficult to discern the relative contributions of size, geographic location, and so on.

ADRIAN ROBERT
Spafford, N.Y.

STEPHAN REPLIES: Robert’s point is well taken. In my book How Economics Shapes Science, I explore a number of factors that contribute to scientific productivity and provide a considerable amount of quantitative analysis.

INTERDISCIPLINARY EXCESS

Although I can appreciate Arizona State University’s efforts to redefine the boundaries of existing departments to develop synergies (such as by combining cosmology with geology), as described by Michael M. Crow in “Citizen Science U.,” I can’t help but remember my experience as an undergraduate computer science major

“I am skeptical whether Arizona State University’s consolidation of departments will lead to the same depth of classroom content.”

ERIC MANN *HILLSBORO, ORE.*

at the University of Illinois at Urbana-Champaign. Geology 105 taught me many basic premises about fossil fuels—gross availability, practical aspects to extraction, and application of the various products. I am skeptical that recasting the topic of geology into a larger department spanning from coal production to the formation of gas giants would lead to a similar depth of classroom content.

ERIC MANN
Hillsboro, Ore.

NONCODING DNA’S VALUE

In Stephen S. Hall’s interview with Ewan Birney [“Journey to the Genetic Interior”], Birney deprecates the term “junk DNA” for sequences whose function we do not know, but he is conservative on how much of nonprotein-coding DNA may be functional (“between 9 and 80 percent”). The fact that the entire genome is copied at every cell division suggests that close to 100 percent of DNA must be functional. Had any significant portion of DNA been nonfunctional in the past, evolutionary pressure to develop an editing-out mechanism to increase the cell’s energy efficiency would have been tremendous.

Birney also uses the conservative term “regulation” to describe how the 98.8 percent of nonprotein-coding DNA interacts with the 1.2 percent of protein-coding segments. It is more useful to describe the entire genome as software: instructions for cells to build copies of themselves and assemble cells into life-forms. In this view, the protein-coding segments are thought of as fixed-value strings within the code.

If we could send a personal computer with Microsoft Excel and a copy of its

source code back in time to Alan Turing, it seems unlikely that on comparing the screen output with the source code, Turing would conclude that fixed values such as “File,” “Edit” and “View” were the essence of the software and that the other 99 percent merely “regulated” the operation of the fixed values.

MALCOLM HAMER
New York City

SPEAKING SCIENCE

In “Culture of Creativity,” Fred Gutler interviews Paul Nurse, who concludes, “Scientists speak the same language.” This may be figuratively true of the language of science, but verbally, they speak many different languages. It might thus be interesting to read an article on the language barriers to scientific communication and how they are overcome. Because American science predominates, is English the lingua franca of global science? Do our schools promote STEM students learning foreign languages?

DAVID W. BRIGGS
Marion, Mass.

WHY NOT WIDGETS?

In “Why Germany Still Makes Things,” Stefan Theil points to the use of new technology and manufacturers and researchers working closely as major reasons German manufacturing remains competitive.

Both the U.S. and Germany still excel at making complex, high-tech items, but it seems that the former can no longer economically produce simple items, such as Keck clips (plastic clips used to hold pieces of glassware together), whereas the latter still can. Perhaps Germany has something to teach us in this sort of manufacturing as well.

HOWARD J. WILK
Philadelphia

EMPATHY AND PSYCHOPATHY

“The Wisdom of Psychopaths,” excerpted from a book by Kevin Dutton, refers to a lack of empathy as a psychopathic trait that can be beneficial. Yet the term “psychopath” refers to a person whose behaviors are habitually amoral and antisocial.

The intensely focused individuals cited by Dutton are engaged in prosocial activities, which is moral, not psychopathic, be-

WE HAVE MORE STRENGTH
IN OUR LITTLE TOE THAN
THEY HAVE IN THEIR WHOLE SOCK.



All socks are not created equal. Want proof? Get a pair of Gold Toe socks. For more than 80 years, we've knit each pair to last, with reinforced toes for extra durability. They're comfortable too, thanks to our specially flattened toe seams. And with a variety of fashionable patterns and colors to choose from, there's no good reason to buy another brand of socks ever again. Gold Toe. Style that lasts. To learn more, visit GoldToe.com.

GOLDTOE[®]
The best socks on two feet. 

havior. Principles such as a rationality, identity, group or creedal loyalties, fears of punishment/consequences and long-range self-interest direct their morality even though they lack empathy. Lack of empathy does not make a psychopath. Dutton's "wisdom" of psychopathy is a misnomer.

ANDREW D. WHITMONT
via e-mail

DUTTON REPLIES: No one defining feature separates the psychopath from the nonpsychopath. The characteristics that mark psychopaths out from the rest of us, like any other personality characteristic, are evenly distributed across the general population as a whole. Just as there exists no official dividing line between someone who plays the piano and a concert pianist, the frontier between a "pure" psychopath and someone who merely "psychopathizes" is blurred. One individual, for example, may be ruthless, fearless and demonstrate a sublime lack of empathy but at the same time act neither violently nor antisocially nor without conscience.

Scoring high on three psychopathic characteristics, such as an individual might rightfully be considered further along the "psychopathic spectrum" than one scoring low on those three traits but wouldn't be anywhere near the "danger zone" of someone scoring high on all of them.

Taking such a dimensional perspective on psychopathy, there is indeed "wisdom" to be found in possessing various combinations of psychopathic traits, at various levels, across various professional contexts.

THE BRAIN AND AGENCY

"The Language of the Brain," by Terry Sejnowski and Tobi Delbruck, raises several philosophical questions. The phrase "the brain makes sense of our experiences" spurs the question of where the implied "I" comes in. Later, I read that "a neuron fires a spike after deciding..." So neurons do the deciding! And further on, we have: "the brain takes such synchrony to mean that the signals are worth noting."

The question is: What is the difference between brain and mind, and how much control does my brain or mind (or I) have over my actions and thoughts?

ANDREW MILNE
Dunstable, England

SCIENTIFIC AMERICAN™

ESTABLISHED 1845

Senior Vice President and Editor in Chief
Mariette DiChristina

Executive Editor
Fred Guterl

Managing Editor
Ricki L. Rusting

Managing Editor, Online
Philip M. Yam

Design Director
Michael Mrak

Board of Editors

News Editor
Robin Lloyd

Senior Editors
Mark Fischetti, Christine Gorman, Anna Kuchment, Michael Moyer, Gary Stix, Kate Wong

Associate Editors
David Biello, Larry Greenemeier, Katherine Harmon, Ferris Jabr, John Matson

Podcast Editor
Steve Mirsky

Blogs Editor
Bora Zivkovic

Contributing Editors
Davide Castelvecchi, Graham P. Collins, Deborah Franklin, Maryn McKenna, George Musser, John Rennie, Sarah Simpson

Online Contributor
Christie Nicholson

Art Director, Information Graphics
Jen Christiansen

Art Director, Online
Ryan Reid

Photography Editor
Monica Bradley

Assistant Photo Editor
Ann Chin

Video Editor
Eric R. Olson

Information Graphics Consultant
Bryan Christie

Managing Production Editor
Richard Hunt

Senior Production Editor
Michelle Wright

Art Contributors
Edward Bell, Caitlin Choi, Nick Higgins

Copy Director
Maria-Christina Keller

Senior Copy Editor
Daniel C. Schlenoff

Senior Editorial Product Manager
Angela Cesaro

Editorial Administrator
Avonelle Wing

Copy Editors
Michael Battaglia, Aaron Shattuck

Web Production Editor
Kerrissa Lynch

Senior Secretary
Maya Harty

Senior Production Manager
Christina Hippeli

Advertising Production Manager
Carl Cherebin

Prepress and Quality Manager
Silvia De Santis

Custom Publishing Manager
Madelyn Keyes-Milch

Production Coordinator
Lisa Headley

President

Steven Inchoombe

Executive Vice President
Michael Florek

Vice President and Associate Publisher, Marketing and Business Development
Michael Voss

Director, Advertising
Stan Schmidt

Vice President, Digital Solutions
Wendy Elman

Director, Global Media Solutions
Jeremy A. Abbate

Managing Director, Consumer Marketing
Christian Dorbandt

Associate Consumer Marketing Director
Catherine Bussey

E-Commerce Marketing Manager
Evelyn Veras

Senior Marketing Manager/Acquisition
Patricia Elliott

Sales Development Manager
David Tirpack

Promotion Manager
Diane Schube

Promotion Art Director
Maria Cruz-Lord

Marketing Research Director
Rick Simone

Sales Representative
Chantel Arroyo

Director, Ancillary Products
Diane McGarvey

Custom Publishing Editor
Lisa Pallatroni

Senior Digital Product Manager
Michael Thomas

Online Associate Director
Mike Kelly

Online Marketing Product Manager
Zoya Lysak

LETTERS TO THE EDITOR

Scientific American
75 Varick Street, 9th Floor
New York, NY 10013-1917
or editors@sciam.com

Letters may be edited for length and clarity. We regret that we cannot answer each one. Post a comment on any article at ScientificAmerican.com/feb2013

HOW TO CONTACT US

Subscriptions

For new subscriptions, renewals, gifts, payments, and changes of address: U.S. and Canada, 800-333-1199; outside North America, 515-248-7684 or www.ScientificAmerican.com

Submissions

To submit article proposals, follow the guidelines at www.ScientificAmerican.com. Click on "Contact Us." We cannot return and are not responsible for materials delivered to our office.

Reprints

To order bulk reprints of articles (minimum of 1,000 copies): Reprint Department, Scientific American, 75 Varick Street, 9th Floor, New York, NY 10013-1917; 212-451-8877; reprints@SciAm.com. For single copies of back issues: 800-333-1199.

Permissions

For permission to copy or reuse material: Permissions Department, Scientific American, 75 Varick Street, 9th Floor, New York, NY 10013-1917; randp@SciAm.com; www.ScientificAmerican.com/permissions. Please allow three to six weeks for processing.

Advertising

www.ScientificAmerican.com has electronic contact information for sales representatives of Scientific American in all regions of the U.S. and in other countries.

Scientific American is a trademark of Scientific American, Inc., used with permission.

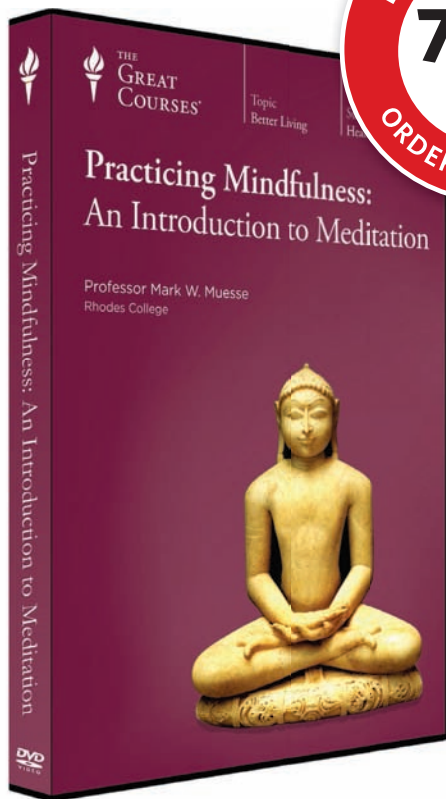

Discover the Essence of Mindful Meditation

In recent decades, science has confirmed that meditation, when correctly practiced, offers lasting benefits for your physical, mental, and emotional health. Now, in **Practicing Mindfulness: An Introduction to Meditation**, experienced meditator and Professor Mark W. Muesse gives you a clear understanding of the essence of meditation—and how best to practice it.

In 24 detailed lectures filled with guided exercises, he teaches you the principles and techniques of sitting meditation, the related practice of walking meditation, the use of meditative awareness in activities such as eating and driving, and more. Emphasizing clarity and practical understanding, his course will leave you with a solid basis for your own practice and for bringing meditation's empowering benefits into every area of your life.

Offer expires 03/22/13

1-800-832-2412

WWW.THEGREATCOURSES.COM/6SA

Practicing Mindfulness: An Introduction to Meditation

Taught by Professor Mark W. Muesse
RHODES COLLEGE

LECTURE TITLES

1. Mindlessness—The Default Setting
2. Mindfulness—The Power of Awareness
3. Expectations—Relinquishing Preconceptions
4. Preparation—Taking Moral Inventory
5. Position—Where to Be for Meditation
6. Breathing—Finding a Focus for Attention
7. Problems—Stepping-Stones to Mindfulness
8. Body—Attending to Our Physical Natures
9. Mind—Working with Thoughts
10. Walking—Mindfulness While Moving
11. Consuming—Watching What You Eat
12. Driving—Staying Awake at the Wheel
13. Insight—Clearing the Mind
14. Wisdom—Seeing the World as It Is
15. Compassion—Expressing Fundamental Kindness
16. Imperfection—Embracing Our Flaws
17. Wishing—May All Beings Be Well and Happy
18. Generosity—The Joy of Giving
19. Speech—Training the Tongue
20. Anger—Cooling the Fires of Irritation
21. Pain—Embracing Physical Discomfort
22. Grief—Learning to Accept Loss
23. Finitude—Living in the Face of Death
24. Life—Putting It All in Perspective

Practicing Mindfulness:

An Introduction to Meditation

Course no. 1933 | 24 lectures (30 minutes/lecture)

SAVE UP TO \$185

DVD ~~\$254.95~~ **NOW \$69.95**

CD ~~\$179.95~~ **NOW \$49.95**

+ \$10 Shipping, Processing, and Lifetime Satisfaction Guarantee

Priority Code: 72831

Designed to meet the demand for lifelong learning, The Great Courses is a highly popular series of audio and video lectures led by top professors and experts. Each of our more than 400 courses is an intellectually engaging experience that will change how you think about the world. Since 1990, over 10 million courses have been sold.

Beware the Destiny Test

Unborn children will soon have their genes mapped. Without proper guidance for parents, the tests could prove calamitous

In a few years you will be able to order a transcript of your entire genetic code for less than \$1,000. Adults cannot do much to alter their biological lot, but what if parents could examine their unborn child's genome? Without proper guidance, they might decide to take drastic measures—even to end the pregnancy—based on a misguided reading of the genetic tea leaves.

Two different university laboratories have developed tests that will reveal the entirety of a fetus's genetic code using just a blood sample from the mother (or that sample plus a drop of saliva from the father). Prenatal whole-genome sequencing will provide volumes of information beyond the currently available tests for genetic disorders such as Down's syndrome or Tay-Sachs disease—assays that parents now use to decide how to respond to a pregnancy. The three billion units of code furnished in the new tests will also dwarf the relative trickle of information provided by consumer gene-testing services such as 23andMe, which currently look (postnatally) only at perhaps about one million locations in the genome.

Any woman who undergoes such a test will quickly learn that there is no such thing as a perfect baby. Parents will encounter hundreds and, as the science progresses, thousands of instances in which a particular variant of a gene may statistically suggest (but not guarantee) their child's future. Will the child-to-be one day suffer from melanoma or diabetes? What about obsessive-compulsive disorder? Moreover, clues will emerge in whole-genome scans about not only health prospects but personality as well—whether she is likely to become an introvert or be able to carry a tune or star in high school sports. Whole-genome scans will tell parents a story about a particular future for their child—a future that those parents may not be rooting for.

A compelling example of the angst-provoking uncertainties involved has been raised by bioethicist and *Scientific American* advisory board member Arthur Caplan. What if a test picks up the gene for albinism? Being an albino is not a disabling medical condition, but it can be a social burden. Might that be enough for some parents to consider ending the pregnancy?

Attitudes toward child rearing might also change, as parents wonder whether their kid is just being bad or whether that tantrum is an example of a dysfunctional serotonin transporter gene.



Without careful planning, moreover, the new prenatal genetics might rob a child of the freedom to make decisions best left until adulthood—whether or not to learn, for instance, if a mutation predicts the inevitability of Huntington's disease 20 years hence.

A customer of 23andMe can receive information via the Internet about a multifold greater risk of breast cancer or Alzheimer's disease without conferring with a genetics counselor. A similar laissez-faire approach to prenatal whole-genome testing, which might involve the decision to abort a pregnancy based on a personal and possibly inaccurate interpretation of dense and confusing genetic data, could portend tragedy.

Ultimately the U.S. Food and Drug Administration, genome-testing companies and professional societies such as the American Society of Human Genetics will need to develop a comprehensive policy on prenatal whole-genome testing. One option is to require that parents receive a filtered set of information from a genetics counselor. Bioethics scholars affiliated with the National Institutes of Health wrote an analysis last summer that calls on the medical community to develop a guide to the most relevant genomic data for future parents (life-threatening disease risk obviously tops the list). The report also recommends safeguarding the future child's right not to be told about later-in-life disease risk until adulthood.

Unfortunately, there aren't nearly enough trained genetics counselors to handle the coming upsurge in demand for this type of information. And neither physicians nor other health professionals know enough about genomics and its relevance to serve as steady guides. Without access to a much higher level of refined expertise, the secrets of our offspring's genetic code will continue to remain an unnerving cipher—or worse. ■

SCIENTIFIC AMERICAN ONLINE

Comment on this article at ScientificAmerican.com/feb2013

AMERICA

AT ITS BEST

2013 Imagine Solutions Conference

[Introducing 8 of the 29 thought leaders for the 2013 Imagine Solutions Conference]



Larry Kramer
USA Today

Catherine Coleman
NASA Astronaut

Jim Rogers
Duke Energy

Shirley Ann Jackson
Rensselaer
Polytechnic Institute

Mark Tercek
The Nature
Conservancy

Julie Taymor
The Lion King

Norman R. Augustine
Lockheed
Martin Corp.

Tyler Mathisen
CNBC
Moderator

Big Ideas. Big Solutions.

For one day, 29 world-class thought leaders will converge on Naples Florida at the Philharmonic Center for the Arts to shine the spotlight on topics of innovation, energy, education, health care, environment, the arts and the economy. This elite group of proven problem solvers share a common goal - to engage with individuals who share their passion and desire to inspire, enlighten and provoke ideas that will make a difference in the future of America.

- » Learn from 29 of the world's most important thought leaders
- » Participate in 5 networking breaks
- » Be a part of great learning, insights, conversations and inspiration
- » In collaboration with Leading National Media Content Partners

We invite you to become part of the solution and join us at the 2013 America At Its Best conference.

- » February 11, 2013
 - » Philharmonic Center for the Arts, Naples, Florida
 - » Attendance is limited to 600 participants
 - » For tickets » 239.597.1900
- www.imaginesolutionsconference.com
www.thephil.org

www.imaginesolutionsconference.com

Content Partners



PROMOTION

Tap into the future.



Get closer to the leading edge of science and technology: experience the SCIENTIFIC AMERICAN Tablet Edition - available for iPad®.



TO RENEW

SCIENTIFICAMERICAN.COM/UPGRADE

TO SUBSCRIBE

SCIENTIFICAMERICAN.COM/TABLET



Michael Fertik is founder and CEO of Reputation.com, which is a member of the World Economic Forum Global Agenda Council on the Future of the Internet.

A Tale of Two Internets

Ninety-nine percent of us live on the wrong side of a one-way mirror

Imagine an Internet where unseen hands curate your entire experience. Where third parties pre-determine the news, products and prices you see—even the people you meet. A world where you *think* you are making choices, but in reality, your options are narrowed and refined until you are left with merely the illusion of control.

This is not far from what is happening today. Thanks to technology that enables Google, Facebook and others to gather information about us and use it to tailor the user experience to our own personal tastes, habits and income, the Internet has become a different place for the rich and for the poor. Most of us have become unwitting actors in an unfolding drama about the tale of two Internets. There is yours and mine, theirs and ours.

Here's how it works. Advertising currently drives the vast majority of the Internet industry by volume of revenue. Silicon Valley is excellent at founding and funding companies that give you free apps and then collect and sell your data when you use them. For most of the Internet's short history, the primary goal of this data collection was classic product marketing: for example, advertisers might want to show me Nikes and my wife Manolo Blahniks. But increasingly, data collection is leapfrogging well beyond strict advertising and enabling insurance, medical and other companies to benefit from analyzing your personal, highly detailed "Big Data" record without your knowledge. Based on this analysis, these companies then make decisions about you—including whether you are even worth marketing to at all.

As a result, 99 percent of us live on the wrong side of a one-way mirror, in which the other 1 percent manipulates our experiences. Some laud this trend as "personalization"—which sounds innocuous and fun, evoking the notion that the ads we see might appear in our favorite color schemes. What we are talking about, however, is much deeper and significantly more consequential.

For example, federal regulations make it illegal to discriminate in pricing access to credit based on certain personal attributes. But, as Natasha Singer recently reported in the *New York Times*, technical advances in mining online and offline data have made it possible to skirt the spirit of the law: companies can simply not make *any* offers to less credit-attractive populations. If



you live on the wrong side of the digital tracks, you won't even see a credit offer from leading lending institutions, and you won't realize that loans are available to help you with your current personal or professional priorities.

For the past decade, e-commerce sites have altered prices based on your Web habits and personal attributes. What is your geography and your past buying history? How did you arrive at the e-commerce site? What time of day are you visiting? An entire literature has emerged on the ethics, legality and economic promise of pricing optimization. And the field is advancing quickly: last September, Google received a patent on technology that lets a company dynamically price electronic content. For instance, it can push the base price of an e-book up if it determines you are more likely to buy that particular item than an average user; conversely, it can adjust the price down as an incentive if you are judged less likely to purchase. And you won't even know you are paying more than others for the exact same item.

These blind walls also appear in our digital political lives. As Eli Pariser has observed, the Internet shows us "what it thinks we want to see" by serving up content that matches the hidden profiles created about us based on our daily online interactions. This behind-the-scenes curation reinforces our political points of view through online "echo chambers" that affirm, instead of challenge, what we already believe to be true. As Harvard University scholar Cass Sunstein has written, liberals and conservatives who deliberate questions openly only with people of the same political stripe become more confident and extreme in their views.

Segregation and separation are on the rise. The fun of personalization has a dark side. ■

SCIENTIFIC AMERICAN ONLINE

Comment on this article at ScientificAmerican.com/feb2013

ADVANCES

Dispatches from the frontiers of science, technology and medicine

ENVIRONMENT

A Dirty Business

Some say increased production at Canada's oil sands means "game over for climate change"

The remote northern corner of Alberta is home to the tar sands, a sprawling deposit of thick, heavy oil that is among the most greenhouse gas-intensive forms of petroleum to produce. In the past decade Canada has become the U.S.'s primary supplier of imported petroleum—ahead of Saudi Arabia—and more than half of it comes from this Florida-size reserve, the only place in the world where oil is mined, not drilled. Should President Barack Obama sign off on construction of the Keystone XL pipeline this year, the flow of tar sands oil, known as bitumen, into the U.S. would increase.

Sourcing more oil from Canada achieves the politically desirable goal of making the U.S. less dependent on OPEC. But bitumen exacts a heavy toll on the environment. As compared with conventional Saudi oil, it emits twice as much greenhouse gas per barrel because of the resources needed to process it. And although it is net-positive—providing between 7 and 10 Btu (British thermal units) of energy for every 1 Btu put into the tar sands—it is less so than conventional petroleum. Once it is mined, bitumen requires large amounts of gas-heated water to melt and separate it from the coarse grains of sand to which it is bound. At that point, the bitumen is still too tarry to

flow, so it has to be chemically manipulated with heat and pressure to become yellowish crude oil, diesel, jet fuel or other typical hydrocarbon products. Or it can be diluted with light hydrocarbon liquids to become pitch-black "dilbit" (for "diluted bitumen"), capable of traveling via pipeline to the U.S.

Some environmental scientists see tapping the oil sands as a disastrous tipping point for global warming. In an analysis of how to restrain warming to an increase of two degrees Celsius or less above preindustrial levels, the International Energy Agency suggested that tar sands production should not exceed 3.3 million barrels a day. Yet approved tar sands production would surpass five million barrels a day—a fact that NASA climatologist James Hansen calls "game over for climate change."

Of course, the true challenge is reducing the use of all fossil fuels, not just oil. U.S. coal-fired power plants produce 10 times more carbon dioxide than Albertan oil sands. Even so, power plant emissions have begun to decline, while the Canadian Association of Petroleum Producers notes that CO₂ pollution from oil sands has risen 36 percent since 2007. As the U.S. weighs construction of the Keystone XL pipeline, the problem of tapping the oil sands is only getting stickier.

—David Biello

JONI LOWENSTEIN Redux Pictures

ASTRONOMY

Ring Theory

The solar system's moons may have emerged from long-gone planetary baubles

As Carl Sagan once said, "If you wish to make an apple pie from scratch, you must first invent the universe." And if you wish to make a moon from scratch, according to new research, you must first create planets with rings (after inventing the universe, of course).

Earth's moon may have emerged from a long-vanished ring system, much like the rings still encircling Saturn—and the same goes for many of the satellites orbiting the other planets. The bulk of the solar system's regular satellites—those moons that stick close to their planets in roughly equatorial orbits—formed this way, rather than taking shape simultaneously with the planets as a direct result of planet formation, French astrophysicists have concluded. The researchers reported their findings in a November 2012 issue of *Science*.

Through theoretical modeling, Aurélien Crida of the University of Nice Sophia-Antipolis and Sébastien Charnoz of the University of Paris Diderot found that the moon-formation action begins at the edge of a planetary ring, where a satellite can take shape without being shredded by the gravitational pull of the planet. There moonlets coagulate from the ring material before migrating outward. As the ring system spits out moonlet after moonlet, the small objects merge to form larger moons, which

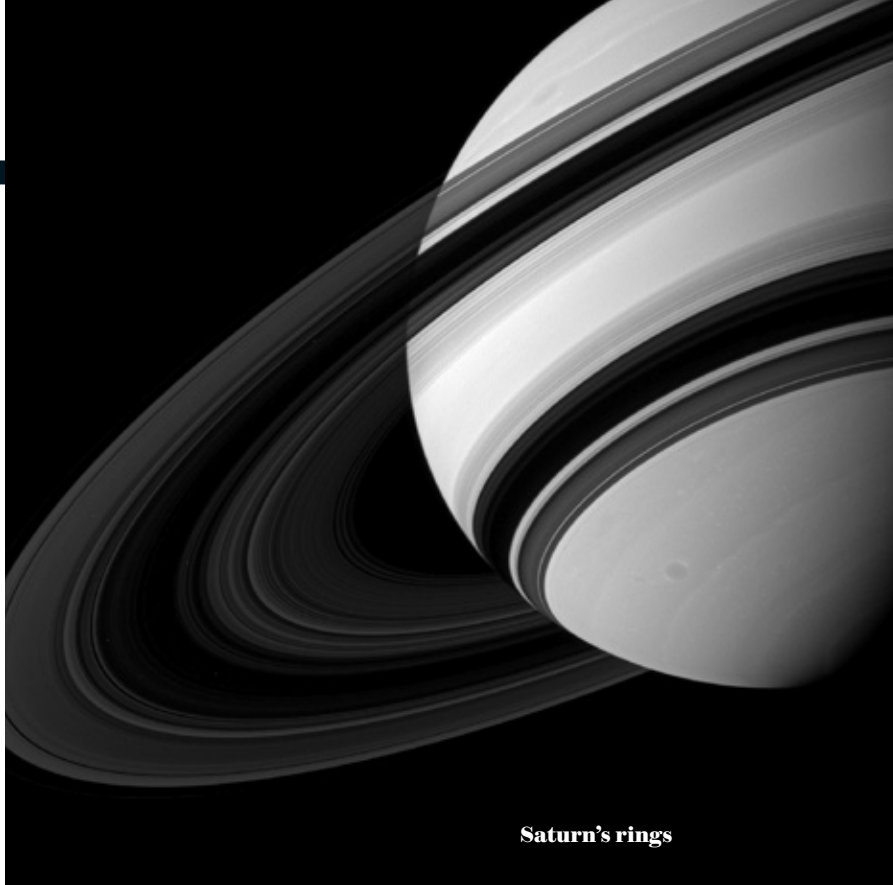

Saturn's rings

may merge in turn as they spiral outward from the planet.

The new hypothesis seems to explain a key commonality among the regular satellites of Saturn, Uranus and Neptune—namely, that moons farther from their respective planet tend to have larger masses than their closer-in neighbors. Like a snowball rolling downhill, the coalescing moons grow larger and larger as they drift farther from the planet and its rings and undergo progressively more mergers along the way. The end result is a neatly ordered satellite system, with small moons on the inside built from few moonlets and large moons farther out built from numerous moonlets.

Planetary scientists generally accept that a giant impact into the newly formed Earth ejected a huge cloud of material that became our moon. In Crida and Charnoz's conception, that ejecta first flattened into a ring around the planet, which then spread out and coagulated into the moon.

The new hypothesis is not without its problems. For example, if extensive, Saturn-like ring systems once adorned Neptune and Uranus, where are they now? "We have a few ideas, but nothing too convincing," Crida says. "But I think we can find good reasons for the disappearance of the rings, and the satellites remain as the smoking gun." —John Matson

HEALTH

Worm Elixir

Parasite eggs may soothe the stomach

Intestinal issues are not just for humans. Rhesus macaques living in captivity often develop chronic diarrhea similar to the human autoimmune condition ulcerative colitis. Now these animals are providing new insights about a cure for this condition in both species—and that cure is worms.

Small human trials have found that giving people pig whipworm eggs can reduce symptoms of inflammatory bowel disease (IBD). In developing countries where IBD is much less common, parasitic

worms (helminths) are often endemic, perhaps conferring some benefit. But scientists have still been parsing out why the presence of these worms might work so well.

For the new study, Ping Loke, an assistant professor of microbiology at New York University Langone Medical Center, and his colleagues selected five juvenile rhesus macaques with idiopathic (cause unknown) chronic diarrhea. Each monkey was fed 1,000 parasitic whipworm (*Trichuris trichiura*) eggs. After the treatment, four of the five monkeys had improved and regained weight. The findings were published online in *PLOS Pathogens*.

The researchers found that the ill monkeys started out with an abnormally high rate of bacteria attached to the mucosal membranes

of their colon. After the treatment, bacterial communities in their colon had changed substantially, suggesting that exposure to helminths may help restore the balance of microbial communities in the gut.

The team speculated that the presence of the parasite eggs stimulated extra mucus production and healing, in addition to renewing epithelial cells, which line the gut. These changes helped to reduce the quantity of bacteria that could attach to the gut lining and rev up the immune response unnecessarily. Loke and his colleagues are now starting a human trial to test pig whipworm eggs as a treatment for ulcerative colitis. If it proves successful and eventually makes it to market, just think of them as the caviar of probiotics. —Katherine Harmon

ADVANCES

**“Braveness in the face of
tofu a plus.”**

(from Science Connection member profiles)

“Looking for someone to write home
to Mother about.”

“Can fix most things, given enough
time & especially if it isn't worth
repairing in the first place.”

“Factor polynomials for relaxation,
want to move on to sequences.”

“Jewish, please. Not important if
religious, but I can't keep explaining
the jokes.”

“Attempts understanding women but
mostly in awe...”



SciConnect.com (Join us!)

PROMOTION

SCIENTIFIC AMERICAN™ Classics

Discover the Future through our Past.

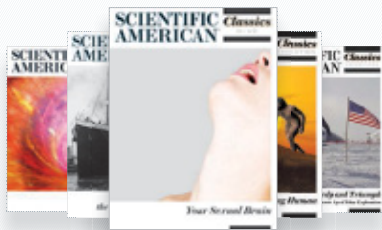

SCIENTIFIC AMERICAN Classics are single-
topic anthologies compiled from
SCIENTIFIC AMERICAN's 167 years of
extensive historical archives as 70+ page
PDFs. New Classics are introduced
weekly and are priced at \$9.99 per issue.

Learn more at
ScientificAmerican.com/Classics
and start your collection today.

Collection includes: A New Look at Human Evolution,
The Hidden Mind, Birth of Flight, Reality-Bending
Black Holes, Tragedy and Triumph, Your Sexual Brain,
The Titanic and Age of the Transatlantic Steamship

ECOLOGY

Where No Tree Has Gone Before

As the climate warms, forests
encroach on meadowland

In perhaps the slowest invasion in history, mountain meadows in the Pacific Northwest—where hikers and backpackers revel in breath-taking scenery—are gradually giving way to hemlocks, Pacific silver firs and other conifers. In these high-elevation, subalpine meadows of Jefferson Park in the central Cascade Range in Oregon, snow typically covers the meadows until July or August and returns again in November or December—too short a growing season for most trees to take root. But with a warming climate, snow has begun melting earlier and growing seasons have lengthened; that extra time with little or no snow cover has given trees a boost. As a result, tree occupation rose from 8 percent in 1950 to 35 percent in 2008, reports a U.S. Department of Agriculture Forest Service-funded study published last October in *Land-scape Ecology*.

At a time when so many forests are threatened, aren't more trees something to celebrate? Not necessarily, say the authors of the new study. These tall trees block light that meadow grasses, shrubs and wildflowers need to survive. Once trees become established, the surrounding seed banks of native grasses tend to fade away. The meadows'

“biodiversity value is much larger than the amount of area they occupy,” explains lead author Harold S. J. Zald, postdoctoral research associate at Oregon State University, who hatched the idea for the study while back-packing in the Cascade Range. The researchers do not yet know which plant or animal species would be endangered.

The scientists did find one bright spot: depressions in the landscape carved out by glaciers held deeper snow that lasted longer through the summer. Such indentations might hold important reservoirs of meadow species even as global temperatures rise, Zald says.

To gather data, the researchers pinpointed study plots with GPS, counted trees by species, measured snow depth in late July, and sleuthed back through time by taking tree core samples to determine their age. Using LiDAR data—“basically laser beams sent down from an airplane,” Zald explains—the team created a precise, three-dimensional map of vegetation, rock and soil, helping the researchers understand where trees became established and how deep the snow was over the rugged landscape.

Although there is still much to learn, the study highlights yet another impact of climate change. “Over the past 20 years in the Pacific Northwest, we've been focused on conservation of old-growth forests as well as conservation of species such as the spotted owl and salmon,” Zald says. “But in the process, we haven't really paid attention to meadow decline. Moving forward, this may be an emerging conservation issue.” —Carrie Madren

Jefferson Park, Oregon



COURTESY OF HAROLD S. J. ZALD, Oregon State University

PATENT WATCH

System and method for aquaculture of marine life-forms: Live corals make a stunning addition to marine aquariums, but harvesting mature coral from the wild threatens rare reef ecosystems. Coral cultivation or aquaculture could help, especially in the U.S., where hobbyists buy approximately 80 percent of the live coral sold in the world. The challenges to culturing corals include generating the kind of multidirectional, strong currents created by waves and tides, which are necessary for reef organisms to thrive. Karen Spartz, who owns an aquaculture business in Indiana, came up with a solution.

Patent no. 8,267,045 describes a system that mimics a marine environment through water chemistry, temperature and the use of natural light to grow a host of organisms, among them sea stars, anemones, fish and corals. Many of these techniques are common solutions in the aquaculture business, but Spartz added a large rotating tray. The wheel-shaped tray is buoyed by floats and balanced by the distribution of individual domesticated corals. A single pump moves water through a refugium—a subtank separated from, but sharing water with, the main tank—containing macroalgae that filter and clean the water. Well-placed outlets funnel the water back to the main tank and spin the tray, giving riding organisms a constant current. “The corals like turbulence,” she says.

Spartz’s patent also proposes a variation: a tray rigged with sails and propelled by a fan. The wind-powered setup could be used to culture organisms such as sea horses and nudibranchs, which do not tolerate direct water flow, says David Baker, an assistant professor of biological sciences at the University of Hong Kong. —Marissa Fessenden

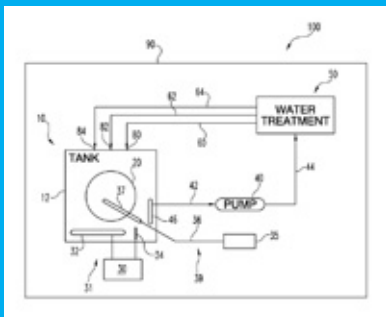

PHYSIOLOGY

Your Brain on Sports

New evidence links athletic injuries to debilitating damage

Helmets protect the heads of football players and military personnel—but they can’t fully protect the brain from damage as it bumps against the skull after impacts. Studies have linked such repeated trauma to a devastating brain disease. On December 2, 2012, researchers at the Boston University School of Medicine, the U.S. Department of Veterans Affairs and other institutions published findings online in the journal *Brain* that document the changes caused by chronic traumatic encephalopathy (CTE). The analysis offers the most detailed portrait yet of the disease’s pathology and how it is distinct from other neurodegenerative disorders such as Alzheimer’s disease.

The researchers analyzed samples from the postmortem brains of 85 subjects, including athletes and veterans who had a history of traumatic brain injuries. These samples revealed the disease’s progressive course through the brain, including the presence of tangled tau proteins, a marker of cognitive

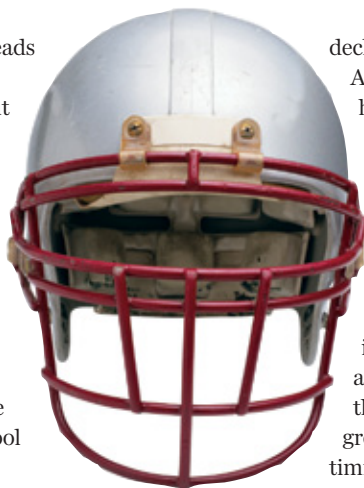

decline also associated with Alzheimer’s. In CTE, however, these tangles appear in different regions of the brain and spread in a distinctly patchy manner. The initial abnormalities seem to reflect the physical injury, and work with animal models suggests that the disease’s progression may relate to timing between injuries: when there is insufficient opportunity to heal, each subsequent hit further damages the brain.

The study strengthens the argument that head injuries sustained by athletes contribute to this disease. Of the 85 subjects, 68 cases had CTE, of whom 64 had played contact sports such as football or hockey. The study, however, does not explain why individuals with similar histories do not show signs of this disease. Study author and neuropathologist Ann McKee of the Bedford Veterans Affairs Medical Center in Massachusetts says, “It really speaks to the urgency of more research to figure out why some people—probably genetically—are pre-disposed” to CTE. —Daisy Yuhas

CONQUER MATH & SCIENCE!

QUALITY COURSES TAUGHT WITH STEP-BY-STEP EXAMPLE PROBLEMS

MathTutorDVD.com

All courses viewable online or on DVD

Basic Math

- ✓ Addition, Subtraction
- ✓ Multiplication, Division
- ✓ Fractions, Decimals
- ✓ Percents, and more!

Intermediate Math

- ✓ Algebra 1, Algebra 2
- ✓ College Algebra
- ✓ Geometry
- ✓ Trigonometry

Advanced Math

- ✓ PreCalculus
- ✓ Calculus 1, 2, 3
- ✓ Differential Equations
- ✓ Probability & Statistics

Calculator Tutorials

- ✓ Texas Instruments TI-84
- ✓ Texas Instruments TI-89
- ✓ Hewlett Packard HP-50

Chemistry

- ✓ Unit Conversion
- ✓ Temperature, Density
- ✓ Atomic Theory
- ✓ Compounds, Isotopes
- ✓ Chemical Reactions
- ✓ Stoichiometry, Solutions
- ✓ Acids, Bases, and more!

Physics

- ✓ Projectile Motion
- ✓ Newton's Laws, Work
- ✓ Kinetic & Potential Energy
- ✓ Rotational Motion
- ✓ Thermodynamics
- ✓ Oscillations, Waves
- ✓ Electricity, Magnetism, and More!

Engineering

- ✓ Engineering Circuit Analysis
- ✓ Matlab Tutorials

Order by Phone: 877-MATH-DVD

GUARANTEED MONEY BACK

AWARD WINNING COURSE

About Jason Gibson:

Jason has earned advanced degrees in Engineering and Physics, worked as a Rocket Scientist for NASA, and has a passion for teaching Science and Math!

Save 10%

Use Coupon Code "sciam" and save 10% on your order!

Order Online at:

MathTutorDVD.com

COURTESY OF U.S. PATENT AND TRADEMARK OFFICE (top); GETTY IMAGES (bottom)

MEDICINE

Stopping Superbugs

Real-time genetic sequencing could keep hospital outbreaks in check

Genetic sequences of drug-resistant bacteria have helped scientists better understand how these dastardly infections evolve and elude treatment. Preventive measures such as increasing health care worker hand washing and isolating infected patients have reduced the spread of many health care-acquired infections. Yet these preventable infections still kill some 100,000 patients in the U.S. every year.

Researchers might soon be able to track outbreaks in real time, thanks to advances in sequencing technology. Genomics has the capacity to “revolutionize current practice in clinical microbiology,” wrote Mark Walker and Scott Beatson of the School of Chemistry and Molecular Biosciences and the Australian Infectious Diseases Research Center at the University of Queensland in Australia, in an essay published online last November in *Science*. Until now clinical microbiology has relied primarily on culturing pathogens in the laboratory to study strain differences—a time-consuming process.

Some promising examples have already emerged. A 2011

MRSA

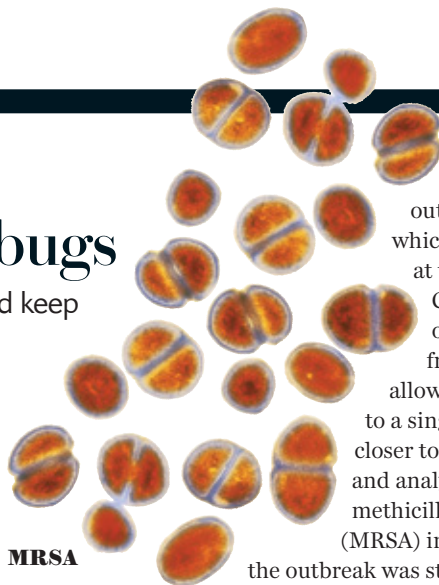

outbreak of *Klebsiella pneumoniae* (KPC), which is resistant to most known antibiotics, at the National Institutes of Health’s Clinical Center killed 11 patients and infected many others. Genetic sequencing of samples from patients and from health care workers allowed epidemiologists to track the outbreak to a single patient and to trace its spread. Moving closer to real-time tracking, researchers sequenced and analyzed strains from a 2011 outbreak of methicillin-resistant *Staphylococcus aureus* (MRSA) in a hospital in Cambridge, England, while the outbreak was still occurring. The tests helped doctors and researchers identify a clear infection cluster in the neonatal intensive care unit, differentiating the bacteria from strains present in other clinics and hospital areas. Microbiologists were then able to trace potential means of spread and reduce the risk of further infections.

These instances “point to a future in which direct sequencing of clinical samples allows same-day diagnosis, antibiotic-resistance gene profiling and virulence gene detection,” Walker and Beatson wrote. Such sequencing and analysis are still too expensive and labor-intensive for most health care institutions. Yet as technologies improve, putting the tools within reach, clinical microbiologists might be soon able to stop these superbug outbreaks before they start.

—Katherine Harmon

NASA

Naps in Space

New lamps could help astronauts get more shut-eye

How many NASA engineers does it take to change a lightbulb?

The question is no joke to NASA, which is investing \$11.4 million to change out aging fluorescent lights in the International Space Station’s U.S. On-orbit Segment. When NASA began considering the replacements, doctors realized they had an opportunity to tackle an entirely different problem: astronaut insomnia.

Sleep deprivation’s fuzzi-ness is an annoyance on Earth but dangerous in space. Although their schedule allows for 8.5 hours of shut-eye a day, astronauts average barely six hours, says NASA medical officer and flight surgeon Smith Johnston. A combination of floating, noise, variable temperature, poor air circulation, backaches and headaches, and a new dawn every 90 minutes confuses circadian rhythms. NASA hopes to fix at least part of the problem with new lamps.

Sleep scientists have found that when specific light receptors in our eyes are exposed to a particular wavelength of blue light, we feel more alert because the brain suppresses melatonin, a key hormone in

regulating sleep. In contrast, red-spectrum light lets the melatonin flow.

The new lamps, from Boeing, comprise a rainbow of more than 100 LED bulbs cloaked by a diffuser, so they appear to be a single panel of white light, says Debbie Sharp, a Boeing senior manager. The fixtures have three modes, each with a subtly different hue: white light is for general vision; a cooler, blue-shifted light promotes alertness; and a warmer, red-shifted light triggers sleepiness. Boeing and its subcontractors expect to deliver 20 lamps in 2015.

In the meantime, scientists at institutions such as Harvard Medical School and Thomas

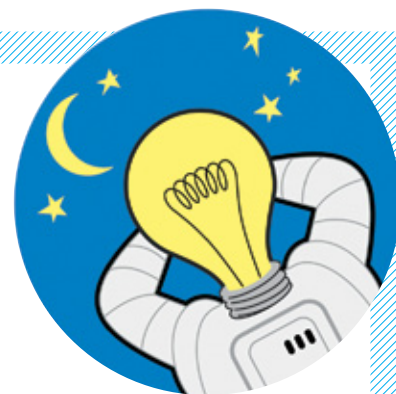

Jefferson University are testing the lamps’ efficacy.

The technology could one day be widespread back on Earth, perhaps illuminating hospital rooms, nuclear submarines, factories or classrooms. “Just because the world has been using fluorescent lighting for years doesn’t mean it’s the best,” says study collaborator Elizabeth Klerman of Harvard.

—Katie Worth

NEW VERSION

ORIGIN[®] 9

Data Analysis and Graphing Software.
Powerful. Flexible. Easy to Use.

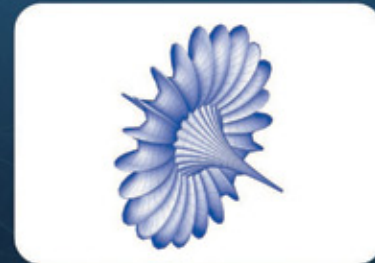
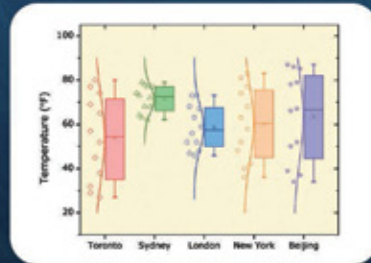
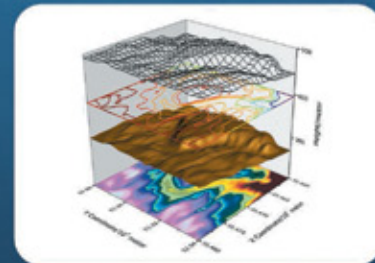
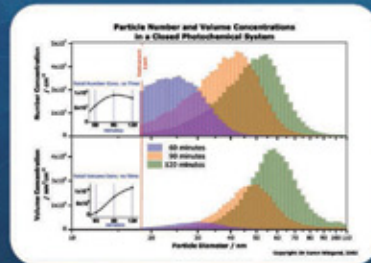
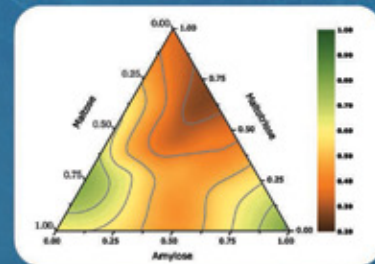
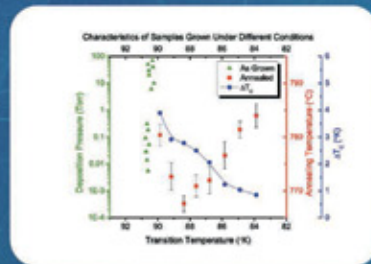
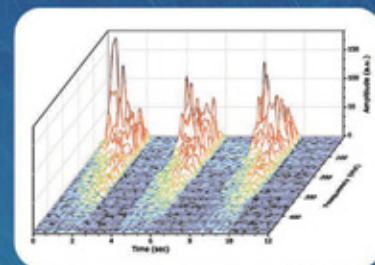
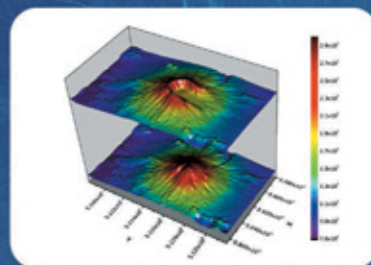

New features include:

- High-performance 3D Graphing using OpenGL
- 3D Parametric Function Plots
- Movie Creation
- Data Filter
- Floating Graphs in Worksheets
- Global Vertical Cursor
- Implicit Function Fitting
- IIR Filter Design



For a complete product tour, visit www.OriginLab.com/scientific

OriginLab Corporation
One Roundhouse Plaza
Northampton, MA 01060 USA

USA: (800) 969-7720
FAX: (413) 585-0126
EMAIL: sales@originlab.com

EVOLUTION

Bug-Eared

Katydid ear structures resemble those of humans

In a striking example of how two unrelated creatures can evolve similar traits, researchers have discovered that a rain-forest grasshopper has ears remarkably like those of humans and other mammals—even though its hearing organ is tucked into the crook of its front legs.

The insect, a yellow-orange-faced katydid (*Copiphora gorgonensis*) from Gorgona Island in Colombia, has ear structures that are similar to the human eardrum and cochlea. As sound waves approach the katydid's legs, they rock a thin membrane akin to a human eardrum. This membrane translates larger movements from air-pressure waves to smaller, more powerful motions in another structure called the cuticle plate. The plate, in turn, creates ripples in a fluid-filled chamber akin to an unfurled human cochlea. Inside this chamber, sensory cells are arranged like a keyboard from high- to low-frequency sensitivity, much like in humans.

C. gorgonensis's exquisitely evolved ear may help it avoid predators such as bats, says sensory biologist Fernando Montealegre-Z, now at the University of Lincoln in England and lead author of the study, which appeared in *Science*. The finding "is yet another remarkable demonstration of convergent evolution," says Ronald R. Hoy, a professor of neurobiology at Cornell University, who was not involved in the work.

The efficiency of this minuscule system could inspire engineers to create micro-sensors based on the katydid's ear design—for example, for use in hearing aids. Such sensors could be less fragile, smaller and more sensitive, potentially spurring applications we have not thought of yet.

—Marissa Fessenden



COURTESY OF FERNANDO MONTEALEGREZ, University of Lincoln

SADIGH GALLERY
ANCIENT ART, INC.

**FREE
COLOR
CATALOG**
★★★★★

Call Toll Free
1(800)426-2007
to Get One!

**AUTHENTIC ANCIENT
ARTIFACTS AND COINS**
303 Fifth Ave Suite 1603 • New York, NY 10016
www.sadighgallery.com

Protect your privacy!

Burn Sensitive Financial Documents SAFELY with the

Portable Burn-Cage™

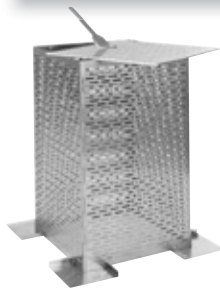

★
**ALL
STAINLESS
STEEL**
★



- ✓ **Clean efficient fires.** Perforated lid and sidewalls maximize airflow and trap burning embers. High burn temperatures mean thorough incineration with less residue and ash.
- ✓ **Lightweight and portable.**
- ✓ **Peace of Mind.** It's the *SAFE* way to burn.
- ✓ **Folds for easy storage.**

77389X © 2013

TOLL-FREE
800-696-8528
DRpower.com/sci



ADVANCES

SCIENTIST IN THE FIELD

Cloud Catcher

An atmospheric scientist recounts her travels to Iceland to learn how dust particles affect cloud formation

The microphysics of cloud formation and the impact of clouds on climate are some of the biggest unresolved questions in climate change research right now. As part of Ben Murray's research group at the University of Leeds in England, my work focuses on ice nucleation, which refers to the formation of ice crystals in clouds. Such crystals generally require a surface for nucleation, and in the atmosphere those surfaces are minute particles, or aerosols. We'd like to know more about how pollutants and particulate matter that get into the atmosphere influence climate through cloud processes. Will pollution lead to more or fewer clouds? How is that going to effect global temperatures? Right now we can't really say.

In the first week of November of last year, my colleague Samuel Dorsi and I traveled to Iceland. The overall goal of the trip was to find some fine-grained sediment smaller than 10 microns, which is material we think is going to get into the atmosphere, for later laboratory experimentation.

Glacial erosion produces very fine sediments, and along the southern coast of Iceland these sediments are spread out on extensive floodplains. Iceland is an extremely windy place, where powerful winds meet broad glacial floodplains. Huge amounts of dust get lofted into the atmosphere. These dust plumes are so large they can be seen in satellite images, streaming for hundreds of kilometers off the coast.

Working our way along the south coast of Iceland, we'd stop on the wide-open plains that lie between the glaciers and the North Atlantic. We'd hike out across pitch-black volcanic cobble and sand in search of

deposits of fine sediments.

The retrieved samples are now safely stored in the freezer because we want to preserve the original composition and chemistry as much as possible. In the lab, we suspend the dust in tiny cloud droplets and observe the temperatures at which they freeze.

Results from our experiments can be used in atmospheric models and give us a better understanding of the effects of cloud on climate. For example, low, liquid-water clouds reflect a lot of solar radiation back to space and have a net cooling effect, but high clouds like cirrus are optically thin and let solar radiation in.

—As told to Marissa Fessenden

PROFILE

NAME
Kelly Baustian

TITLE
**Postdoctoral
research fellow**

LOCATION
**School of Earth
and Environment,
University of Leeds,
England**



COURTESY OF SAMUEL DORSI

WHAT IS IT?

Social cells: The slime mold *Dictyostelium discoideum* spends much of its time as an apparently typical microscopic single-celled amoeba, oozing around in wet soil as it grazes on bacteria. Something truly odd happens, however, when the food runs out. Starving *D. discoideum* band together to form a conglomerate organism. A multicellular slug of sorts, the group grows into a spore-making tower, a beacon for sending amoebae out to richer grounds. The sudden lifestyle change is interesting enough, but the real evolutionary puzzle is the cells that make up the delicate stalk. They die without reproducing, which means cells at the top of the tower can turn into more effective spores. This form of altruistic sacrifice has fascinated biologists for decades. (It appears that related amoebae are more likely to group together, so even the dying cells get to pass on their genes.) Here is an organism that is both solitary and fully, suicidally social, a nearly perfect model creature for understanding how multicellular life emerged from the amoebae. In this shot, a slice through a culture dish, you can see a progression of slugs into towers.

—Alex Wild

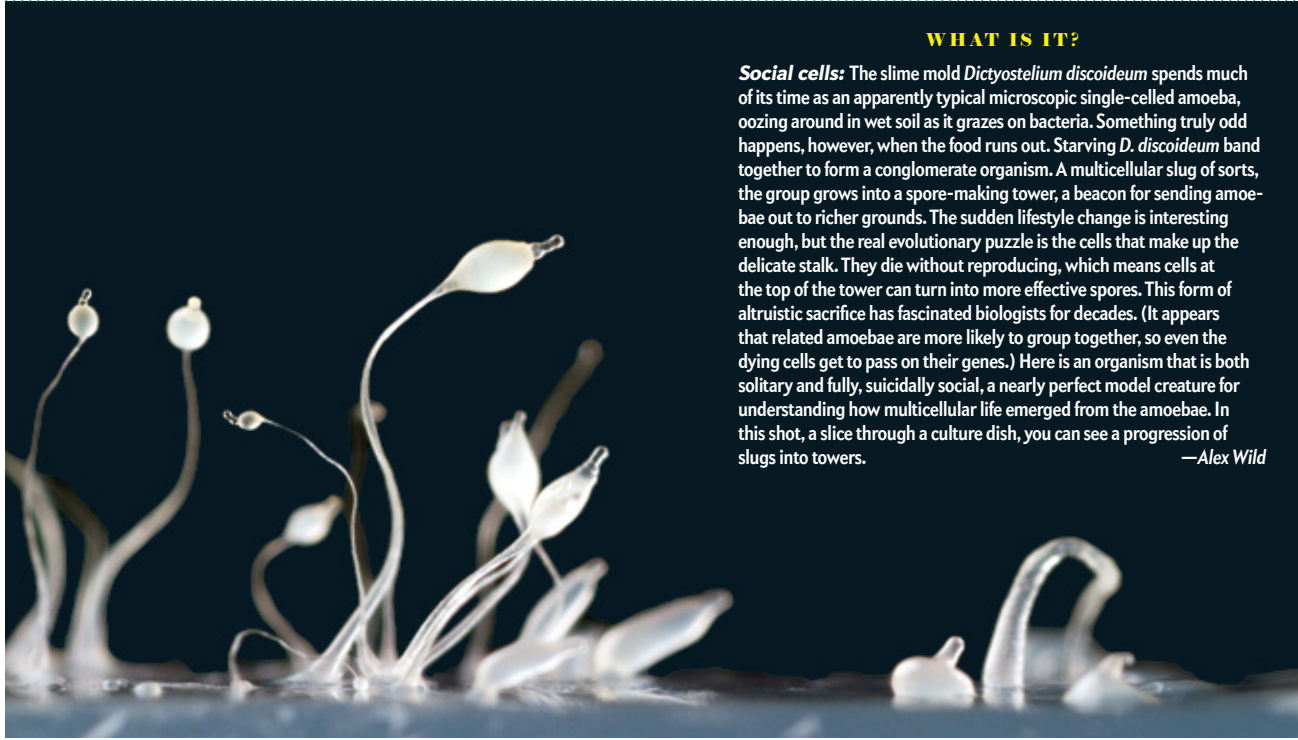

the **ABILITY**
TO GREET STRANGERS

the **CONFIDENCE**
TO WIN THEM OVER

The best part about learning a new language is using it. It connects you to the world in a whole new way. And you'll move with a swagger that might just take you by surprise.

LEVELS 1, 2 & 3

\$399

LEVELS 1, 2, 3, 4 & 5

\$499

FREE 2-DAY SHIPPING

USE PROMO CODE: SAS023
(877) 291-4447

RosettaStone.com/ability



**Rosetta
Stone** 

Live life fluently.™

©2012 Rosetta Stone Ltd. All rights reserved. Free 2-Day shipping for products shipped within the contiguous United States only. Offer limited to TOTALE CD-ROM set purchases made directly from Rosetta Stone and cannot be combined with any other offer. Offer valid through March 31, 2013. Rosetta Stone TOTALE includes interactive online services that require online access and are offered on a subscription basis for a specified term. Online services must be begun within 6 months of purchase or are subject to forfeiture.

BIOLOGY

Boring Beetles

Wormholes in art trace species through time

Wormholes aren't just for time travel or teleportation anymore. Some very real and ancient wormholes are now helping to trace the distribution of insect species and artwork.

A biologist found himself in the unlikely world of centuries-old European woodblock print art. There he discovered that many of the small imperfections in the prints could be identified and traced back to specific

species of bugs that had burrowed through the surface of the original woodblock before the print was made. By matching the hole dimensions to the time and locations in which these prints were fashioned, the scientist, Blair Hedges, a professor at Pennsylvania State University, has been able to paint a historic record of wood-boring beetle distribution across Europe—patterns that had previously been unknown. He published his findings in February in the journal *Biology Letters*.

Hedges has nicknamed these telltale traces the “wormhole record.” Adult beetles lay eggs in the crannies of a piece of wood. Once the lar-



Wormy: A blemished print

vae hatch, they slowly descend into the wood, spending three or four years living there and feasting on the cellulose. After these wormlike larvae transform into adult beetles, they burrow out of the wood, creating the holes that have textured so many woodblock prints.

The scientist studied 3,263 wormholes visible in 473 different prints made between 1462 and 1899. He found that there were two distinct sizes of holes: some were 2.3 millimeters across, and others were closer to 1.4 millimeters wide. And there was a distinct pattern of these hole sizes across the European continent: all the smaller holes were found on prints made in the northeast, and the larger holes came from the southwest. He was then able to deduce the species of each beetle: the common furniture beetle (*Anobium punctatum*) in the northeast and the Mediterranean furniture beetle (*Oligomerus ptilinoides*) in the southwest. Hedge's print-based method could help examine wood-boring species' distribution and historical ranges throughout the world, thus indicating changes in local populations and arrival times of invasive species. The technique might also help solve some art-world mysteries, such as the origins of a book or print.

—Katherine Harmon

RIJKSMUSEUM, AMSTERDAM

SCIENTIFIC AMERICAN™

Introducing BRIEFINGS

a new collection of research summaries from *Scientific American*

Scientific American Briefings brings you up to speed with research highlights selected from peer-reviewed, professional science journals. Each issue delivers the most current scientific developments on the topics that matter most to you—simple, easy and fast.



Download FREE Trial Issues!
go to: www.scientificamerican.com/briefings

Subscription only. Monthly e-publications include: Mind & Brain, Nanotechnology, Climate Change & Environment, Health & Medicine, and Space & Physics.



Roots of Genius

A new image collection of Albert Einstein's brain may provide insight into the physicist's profound ability to visualize space and time

Ever since his death in 1955, scientists have asked what features of Albert Einstein's brain contributed to his extraordinary insights into physical laws. Research on the anatomy of Einstein's genius, which dates back decades, faltered because many of the postmortem images and slides of tissue were scattered and became unavailable to researchers.

A study published online last November in *Brain*, based on the most comprehensive collection of postmortem images compiled to date, shows that Einstein's cerebral cortex, responsible for higher-level mental processes, differs much more dramatically than previously thought from that of a person of average intelligence. An edited interview follows with anthropologist Dean Falk of Florida State University, the lead researcher on this project.

What did you find in the study?

Einstein had extraordinary prefrontal cortices, right behind the forehead, which revealed an intricate pattern of convolutions. We know from comparative studies in primates that this part of the brain became highly specialized during hominin evolution. We also know that in humans, this area functions in higher cognition that entails working memory, making plans, bringing plans to fruition, worrying, thinking about the future and imagining scenarios. It is an extraordinarily evolved part of the brain that is related to connections between neurons underneath the surface of the brain. We're hypothesizing that what we're seeing in Einstein's brain is a lot of complexity in these connections.

Anything else unusual?

One of the most interesting things about Einstein's brain has to do with his sensory and motor cortices. We

found an unusual region lower down in the motor cortex that processes information from the face and tongue and laryngeal apparatus. The motor face area in Einstein's left hemisphere was extraordinarily expanded into a big rectangular patch that I've not seen in any other brain. I am not sure how to interpret this. In a famous quotation, Einstein wrote that his thinking entailed an association of images and "feelings"—that for him, the elements of thought were not only visual but also "muscular." What does that mean? I don't know, but in light of what we found in the motor cortex, it's a very interesting quotation.

Do you think this has anything to do with that famous photograph of Einstein sticking his tongue out?

I've been asked that four times in the past three days. The first time the question caught me by surprise, and I said I thought it was just a coincidence. Then I got to thinking about it and went to a mirror to see whether I could get my tongue out as far as Einstein had, and I came pretty close. So I think that wonderful photograph was probably Einstein just being spontaneous and impetuous.

—Gary Stix



energy innovation summit

February 25–27, 2013 | Washington, D.C.

The premier event dedicated to
TRANSFORMATIVE ENERGY SOLUTIONS

- 1 Network with breakthrough technology companies, federal government leaders, entrepreneurs and researchers who are ready to collaborate
- 2 Visit the Technology Showcase and experience first-hand the latest technological advancements across a wide variety of energy sectors
- 3 Hear keynotes from industry leaders and luminaries on the future of energy technology
- 4 Attend practical seminars on core concepts and skills for transitioning cutting-edge technologies into successful commercial products

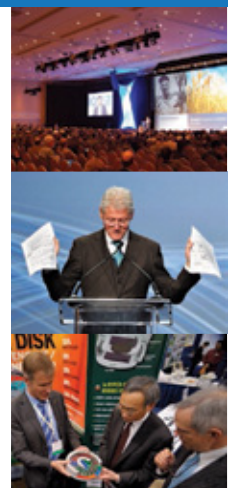

REGISTER NOW AT www.ARPAAE-Summit.com

Best of the Blogs

SPACE

Not Quite Gone

Voyager 1 has not yet entered interstellar space

NASA's well-traveled Voyager 1 is headed out of the heliosphere, the fluctuating bubble in space inflated by plasma streaming outward from the sun. For years Voyager 1 has been closing in on the heliopause—the outer edge of the heliosphere—where the solar wind meets the interstellar medium. Yet despite intriguing hints, the probe remains within the heliosphere, mission scientists announced last December. It appears that Voyager 1 has discovered another wrinkle in the struc-

ture of our local space environment, a kind of magnetic highway linking the heliosphere to what lies beyond.

"We're still inside, apparently," said Voyager project scientist Edward Stone of the California Institute of Technology in a teleconference with reporters on December 3. "But the magnetic field now is connected to the outside. So it's like a highway letting particles in and out."

Voyager 1 crossed into the new region in August, when it registered a huge drop in the

number of low-speed solar particles in its environment and a corresponding jump in the number of higher-energy cosmic-ray particles arriving from outside the solar system.

Despite the influx of cosmic-ray particles, the team concluded that Voyager 1 is still inside the heliosphere because the probe's magnetometer has not yet registered a change in magnetic field direction, as would be expected when crossing the boundary from the sun's plasma to the interstellar medium. "If we had only looked at particle data alone, we would have said, 'Well, we are out. Good-bye to the solar system,'" says Stamatios M. "Tom" Krimigis of the Johns Hopkins

University Applied Physics Laboratory. "But nature is very imaginative, and Lucy pulled up the football again."

Launched in 1977, Voyager 1 is now more than 18 billion kilometers from the sun, farther out than any man-made object has ever traveled. It takes radio signals 34 hours to make the round-trip from Earth to Voyager and back again. Still, no one knows how much farther Voyager 1 may travel before it breaches the heliopause. "It may take several more months—it may take several more years," Stone says. —John Matson

Adapted from Observations at blogs.ScientificAmerican.com/observations

BEHAVIOR

Bird Butts

Used cigarette filters in nests may protect hatchlings

As horrifying as the idea of baby birds growing up in a cigarette-filled home sounds, a new study suggests that some birds may benefit from weaving the fluffy plastic from cigarette butts into their nests. The nicotine lingering in smoked filters may serve as a natural insecticide, driving parasites and other harmful insects away from the nests and the baby birds living within. (Tobacco plants generate nicotine because it defends against insects and their larvae that would otherwise devour the plants.)

The butts are undoubtedly smelly. But birds are actually quite fond of smelly chemicals, such as those found in aromatic plants. Some nest-building species regularly replenish their nests with fresh aromatics, possibly because the chemicals boost the immune system or the development of the chicks. Alternatively, the plant chemicals might act as insecticides.

In the study, researchers at the Autonomous University of Tlaxcala in Mexico set up heat traps, which attract parasites, in 55 nests around Mexico City. Some traps were lined

with filter fluff from smoked cigarette filters. The others were lined with fluff from unsmoked filters, which did not contain nicotine and other smoking by-products. Whether the nest held eggs, chicks or nothing, the unsmoked cigarette traps collected more parasites, suggesting the chemicals drove parasites away and not another property of the filters.

In a second experiment, the researchers collected 28 house sparrow nests and 29 house finch nests from Mexico City immediately after the chicks flew out for good. They found that the more smoked filter fluff padded a nest, the fewer parasites it had.

The missing piece of the puzzle is whether the reduced parasite load in the nests actually provided any benefit to the chicks. It is also unclear if nicotine or another chemical found in cigarettes, such as hydrogen cyanide, arsenic or ammonia, may have turned the parasites out of the nests.

If the results hold, then this study is an example of wildlife adaptation to urbanization—or at least evidence that birds are resourceful and can still follow their noses in urban environments. —Hannah Waters

Adapted from Culturing Science at blogs.ScientificAmerican.com/culturing-science



JOHN DOWNER/Minden Pictures

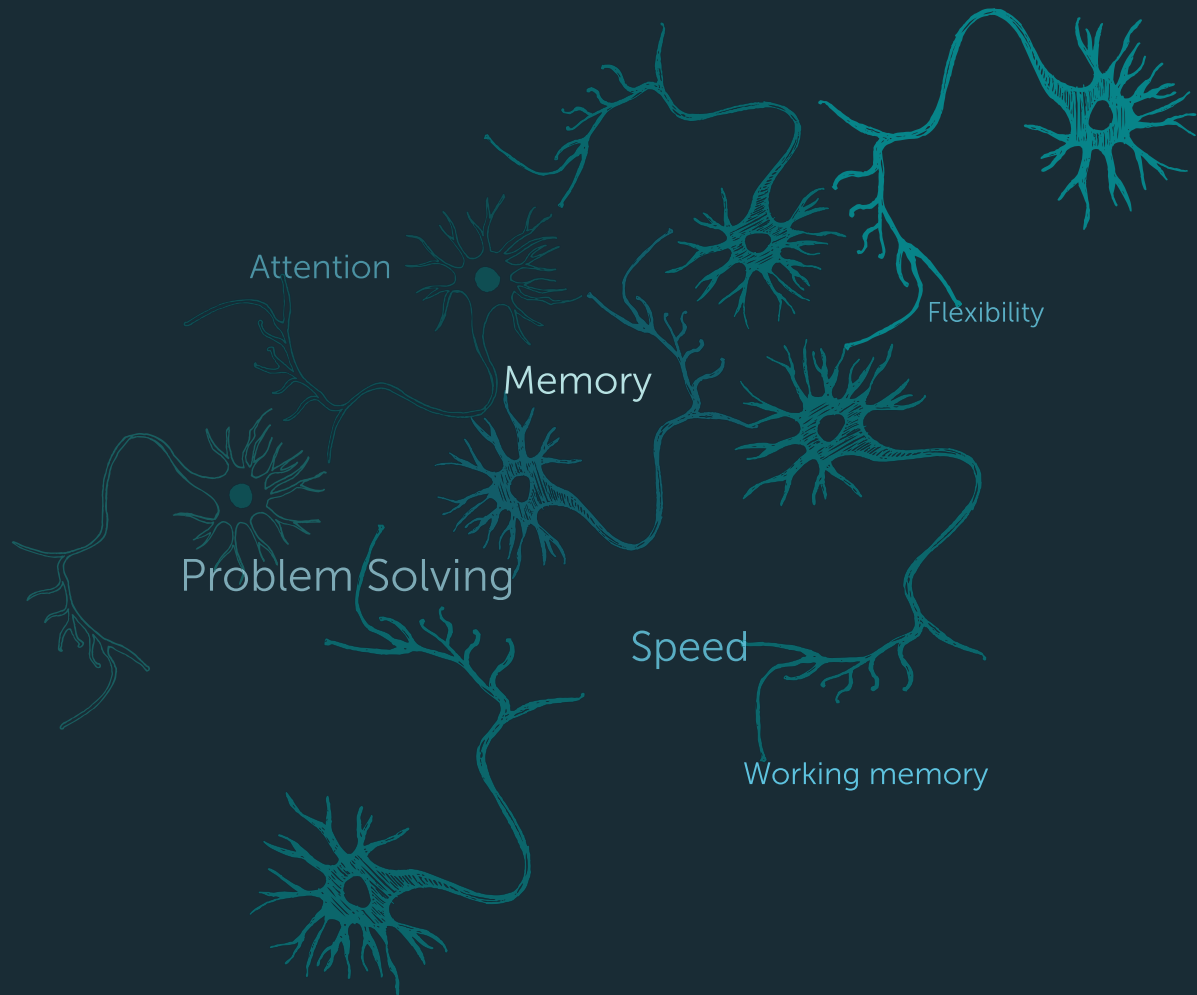

In 2013, unlock the secrets of your brain.

With **30 million users** worldwide and the **largest database** on human cognition ever assembled, Lumosity's brain training program helps leading **research collaborators** understand the human brain.

Now **you** can advance neuroscience research and unlock your own amazing potential in the process: sign up for Lumosity training today.

Every user's progress helps neuroscientists understand the brain a little better. That's how Lumosity makes the world a brighter place.

Unlock your potential at lumosity.com



EBooks that raise your tablet IQ

Science to enrich your life in a format to fit your lifestyle
From the Editors of Scientific American



Recent years have seen a lot of hype about Higgs. Does it exist? Have scientists really found it? Do we need to worry about it creating a black hole? This eBook chronicles the continuing search for the elusive Higgs boson: the theories, the search and the ongoing questions. In essence, what you need to know to separate Higgs from hype.



Is there life on Mars? Was there ever life on Mars? Our relationship with our nearest planetary neighbor has been one of endless fascination. Trace the path of that relationship in the chapters of our eBook, from the earliest observations to NASA's monumental Opportunity rover landing in 2012.

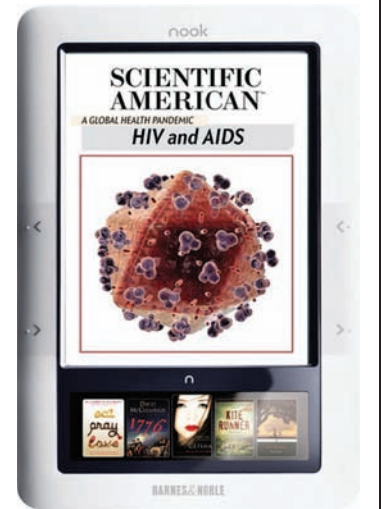

Since HIV first appeared in 1981, more than 25 million people have died of AIDS worldwide. The global health response has seen remarkable progress, but much remains to be done. From the disease's discovery by Gallo and Montagnier to current research on gene editing, this eBook is essential to understanding the struggle against HIV.

LOOK FOR THESE OTHER TITLES

Storm Warnings: Climate Change and Extreme Weather

Back to School: The Science of Education

Battling Drought: The Science of Water Management

Playing Politics: The Science of Elections and Voting

A Question of Time: The Ultimate Paradox

Download Scientific American eBooks now, available wherever eBooks are sold.

| books.scientificamerican.com/sa-ebooks |

**SCIENTIFIC
AMERICAN™**



Deborah Franklin is based in San Francisco and has reported on science and medicine for *NPR*, the *New York Times*, *Fortune* and *Health Magazine*.



A Dangerous Game

Some professional athletes' enthusiasm for certain stem cell treatments outpaces the evidence

In 2005, at the age of 32, then Los Angeles Angel Bartolo Colón won the American League Cy Young Award for best pitcher, one of professional baseball's top honors. He stumbled through subsequent seasons, however, after a series of rips and strains in the tendons and ligaments of his throwing arm, shoulder and back. In 2009 he all but quit baseball. Desperate to reclaim his career, Colón flew home to the Dominican Republic in 2010 for an experimental procedure not vetted or approved by the U.S. Food and Drug Administration. Doctors centrifuged samples of Colón's bone marrow and fat, skimmed off a slurry containing a particular kind of stem cell—immature, self-renewing cells that can turn into a variety of tissues—and injected it into his injured shoulder and elbow. Within months of the procedure the then 37-year-old Colón was once again pitching near the top of his game for the New York Yankees—commanding a 93-mile-per-hour fastball.

Whether the injected stem cells rejuvenated his arm is an open question. The FDA and the International Society for Stem Cell Research warn that no rigorous studies have demonstrated that such treatments safely and effectively repair damaged con-

nective tissue in people. The results of related animal studies, though promising, have raised more questions than answers. "The term 'stem cell' makes it sound cutting edge and exciting," says Paul Knoepfler, a cell biologist at the University of California, Davis, who also writes frequently on policy surrounding stem cells. "But the role of these cells in sports medicine is essentially all hype."

No matter, apparently, to the aging, injured athletes who have followed Colón's lead. Lefty pitcher C. J. Nitkowski, who underwent the same procedure in 2011, told readers of his personal blog that he did not mind the lack of carefully controlled research. "My attitude is I don't have the time to wait for the five- or 10-year study to come out," the then 38-year-old relief pitcher wrote, "so I'm taking a chance now." Besides, Nitkowski figured, even if the treatment did not work, any health risks ought to be slight because the cells involved were his own.

That might not be such a safe bet. Numerous studies suggest that Colón, Nitkowski and others trying untested stem cell treatments may be risking more than they think. Even a syringe of

one's own stem cells taken from one part of the body and squirted into another "may multiply, form tumors, or may leave the site you put them in and migrate somewhere else" the FDA warns on its Web site. More clinical research is needed to define safety procedures, as well as how many cells of which types and what other tissue factors produce the desired results. In some animal studies, for example, the regenerated tissue is not as strong or flexible as the original. In other cases, an overgrowth of scar tissue makes the injected tendon or ligament adhere to the overlying skin. By preventing different tissues from gracefully sliding past one another, these adhesions sometimes pull an even bigger tear in an already serious wound.

In addition, Knoepfler worries that high-profile sports testimonials by Colón, Nitkowski and others will encourage joggers with blown-out knees and the parents of sore-armed Little Leaguers to demand the procedure before it has been thoroughly tested. "When celebrities take to a new treatment, many other people follow suit," he says. Such premature enthusiasm—or an unforeseen tragedy that results from proceeding too fast too soon—could also prevent serious researchers from

getting funding to do the kinds of careful experiments that might eventually lead to safe and reliable treatments.

SEEDS OF REPAIR

THE NEED FOR BETTER WAYS to reknit damaged tendons and ligaments is painfully apparent to the roughly two million Americans in a given year who seek medical help for tears in their shoulder's rotator cuff, for example, or the 100,000 patients in the same year who undergo surgery in the U.S. to repair a ripped or ruptured anterior cruciate ligament (ACL) of the knee. Tendons and ligaments are tough, fibrous bands, made mostly of collagen, that anchor networks of muscles to a bone or link bones and cartilage across crucial joints. They lend strength, flexibility and stability to your daily twists and turns, whether you are rocketing a baseball across home plate or hefting a suitcase into an overhead bin. Once frayed or snapped, they can take many months or longer to mend—even with surgery.

Healing is slow in part because tendons, ligaments and cartilage lack the interlaced blood vessels that other organs rely on for quick delivery of cells involved in repair and growth factors that encourage cells to thrive and divide. Under these circumstances, the rationale for stem cell therapy seems straightforward: bathe the injury in a healing, concentrated wave of tissue-mending cells, and the body will repair itself that much more quickly.

As so often happens in biology, however, applying a simple idea can quickly become more complicated once you start dealing with the details. For starters, the term "stem cell" describes several different types of cells with different capabilities. Embryonic stem cells, for example, can readily give rise to any type of cell found in the body under the right set of circumstances—and when plied with the right set of biochemical signals. In contrast, a more specialized group of stem cells found in the bone marrow generally begets blood cells and immune cells exclusively. These so-called hematopoietic stem cells (from Greek meaning "to make blood") have been reliably used over the past 40 years to seed bone marrow transplants in the treatment of some cancers and immune disorders.

By the 1970s researchers had recognized another type of progenitor cell in the adult bone marrow, which they named the mesenchymal stem cell. In a laboratory dish—and, presumably, also inside the body—these cells readily multiply and give rise to various structural cells, such as fat, muscle, bone, tendon, ligament and cartilage. Studies in animals suggest that mesenchymal stem cells play important roles in the body's ability to heal after an injury, although researchers are still working out the signals and steps required to steer their differentiation into one type of tissue or another.

It turns out, for example, that mesenchymal stem cells do not regenerate tissue in isolation. They depend on other cells and growth factors that may or may not be present in a particular region of inflamed tissue, says Rocky Tuan, who directs the Center for Cellular and Molecular Engineering at the Universi-

ty of Pittsburgh School of Medicine. "You can inject all the best cells," Tuan says, "but if you don't have the right combination of healing goodies around them, it's useless."

Lab studies are also finding that mesenchymal stem cells extracted from different parts of the body can have different attributes. Those found in fat, for example, though relatively plentiful and easy to extract, do not seem to form cartilage as readily as those that come from bone marrow, Tuan says. Other studies suggest that mesenchymal stem cells also modulate the immune system and may have some part in the spread of tumors. Gathering much more basic information about how these cells behave is a vital first step before any safe and broadly reliable treatment can be developed for people, Tuan and other leading stem cell scientists argue.

GALLOPING AHEAD OF THE SCIENCE

UNDETERRED, advocates for the immediate use of stem cell therapy in human athletes point to successes with racehorses as the best evidence that the treatment works. Yet some experts say that the same hype that makes human testimonials unreliable has enveloped company-sponsored studies of competitive horses, too.

In the July 2012 issue of *Equine Disease Quarterly*, Wesley Sutter of Lexington Equine Surgery and Sports Medicine in Kentucky cautioned: "To date, no published controlled clinical studies show efficacy in use of stem cell treatment for any of the conditions being treated."

Carol Gillis, a longtime veterinarian and researcher who specializes in soft-tissue injuries in racehorses, says that the more than 22,000 ultrasound images she has captured in her studies and clinical practice have convinced her that with a tightly regimented exercise program, tendons and ligaments will heal, producing strong, well-organized fibers—

all without the use of stem cells. The reason that many soft-tissue injuries end a horse's racing career, Gillis explains, is because most owners allow the animal to run free too soon, when the pain from the initial injury has faded but the tissue is still fragile.

The ebbing summer of 2012 found Nitkowski working on a new sidearm delivery with a Minor League Mets team, still hoping to return to the Majors as a 40-year-old in 2013. Meanwhile the professional story of Colón, now an Oakland Athletic, entered a darker chapter on August 22, 2012, rendering his experiment with stem cells moot. The 39-year-old's season ended that day when Major League Baseball officials suspended him for 50 games—because he tested positive for the performance-enhancing drug synthetic testosterone. On November 3 the Oakland A's gave Colón a \$3-million, one-year contract extension, which begins as soon as his suspension ends. ■

Gathering much more basic information about how mesenchymal stem cells behave is a vital first step before any safe and broadly reliable treatment can be developed for people.

SCIENTIFIC AMERICAN ONLINE

Comment on this article at ScientificAmerican.com/feb2013



David Pogue is the personal-technology columnist for the *New York Times* and an Emmy Award-winning correspondent for CBS News.

Out with the Real

Why digital design doesn't have to imitate the physical world

Last fall Apple fired executive Scott Forstall, considered by many to be a Steve Jobs protégé. His departure prompted a flurry of discussion about a formerly obscure design-industry concept that he had championed: “skeuomorphism.”

In the physical world, a skeuomorph is an ornamental version of something that was, in an earlier product, a functional necessity. Fake shutter sounds in digital cameras. Fake candles in electric chandeliers. Fake grain in leatherette.

In software, skeuomorphs are everywhere. Desktop folders look like physical filing folders, the Trash can looks like a waste-paper basket and the Save button looks like a floppy disk.

Those shapes don't serve any technological function. But there is, of course, a human reason for software skeuomorphs. In the 1980s, to help the public make the transition to computers, Apple and Microsoft designers chose real-world shapes for on-screen icons to convey their meanings. Jobs, in particular, was a fan of skeuomorphic designs. And in the beginning, they played a big role in helping the graphic user interface catch on.

These days there's a building backlash to skeuomorphic design—a rising sense that Apple has gone too far.

When you turn a page in an Apple e-book, the “paper” curls as you flip it over, even revealing the faint image of words printed on the other side. Apple's Contacts app looks like a physical address book, complete with fake “staples” in the “binding” between “pages.” The background screen of its Game Center app is made to look like green felt, as on a Vegas gaming table. And, perhaps most superfluous of all, torn-off paper scraps adorn the top of the Calendar program's “binding,” as though previous months' pages have been torn away.

These design features, critics argue, no longer help novices make a transition. You don't need unsightly paper remnants to understand that you are using a calendar. A curling-page animation just slows the reader down for the sake of showing off. Meanwhile slavish dependence on real-world visual metaphors

could be holding back more creative, space-efficient or self-explanatory designs.

Sometimes Apple uses skeuomorphs that would not even make sense to modern-day customers. How many members of Generation Y have ever even used a Rolodex? In Apple's new Podcast app for the iPhone, the dominant visual element is a reel-to-reel tape—a technology that fell out of use 30 years ago.

Microsoft's latest operating systems—Windows Phone, for example—run full bore the opposite direction. Their interfaces

are all digital, with no references to the physical world. The designers are clearly saying, “It's 2013, people. We don't need fake wood grain and green felt to convey software functions.”

Many Apple designers would probably argue that helping novices recognize software functionality isn't the sole objective. They would probably point out that detailed photorealistic depictions of physical things also look cool. Yes, it's showing off, but it's part of making something pleasant to use. In truth, many of the complaints come from other designers. You don't hear the masses—people who are actually buying these products—gripping about those little digital staples.

In any case, Apple's famous chief of hardware design, Jony Ive, is now in charge of software design as well, and he's not a fan of skeuomorphism in software. The days of iPhone apps that have fake wood grain, fake brushed metal and fake stitching in fake leather are probably numbered.

And that's fine. Skeuomorphism in software has its place when used well: it can put you at ease with a new program in a flash and convey functions with simple visual metaphors (camera apps will always have camera icons). As with any design concept, this one can be taken too far. The instant a skeuomorph makes software less pleasant to use, somebody should rein it in. ■



SCIENTIFIC AMERICAN ONLINE

Five of Apple's realism flops: ScientificAmerican.com/feb2013/pogue



Rodrigo Quian Quiroga, a native of Argentina, is professor and head of the Bioengineering Research Group at the University of Leicester in England. He is author of the recently published *Borges and Memory: Encounters with the Human Brain* (MIT Press, 2012).



Itzhak Fried is a professor of neurosurgery and director of the Epilepsy Surgery Program at the U.C.L.A. David Geffen School of Medicine. He is also a professor at the Tel Aviv Sourasky Medical Center and Tel Aviv University.



Christof Koch is professor of cognitive and behavioral biology at the California Institute of Technology and chief scientific officer at the Allen Institute for Brain Science in Seattle.



NEUROSCIENCE

Brain Cells for Grandmother

Each concept—each person or thing in our everyday experience—may have a set of corresponding neurons assigned to it

*By Rodrigo Quian Quiroga,
Itzhak Fried and Christof Koch*

IN BRIEF

For decades neuroscientists have debated how memories are stored. That debate continues today, with competing theories—one of which suggests that single neurons hold the recollection, say, of your grandmother or of a famous movie star.

The alternative theory asserts that each memory is distributed across many millions of neurons. A number of recent experiments during brain surgeries provide evidence that relatively small sets of neurons in specific regions are involved with the encoding of memories.

At the same time, these small groupings of cells may represent many instances of one thing; a visual image of Grandma's face or her entire body—even a front and side view or the voice of a Hollywood star such as Jennifer Aniston.

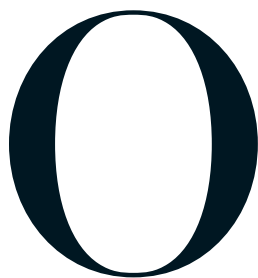

ONCE A BRILLIANT RUSSIAN NEUROSURGEON NAMED Akakhi Akakhievitch had a patient who wanted to forget his overbearing, impossible mother.

Eager to oblige, Akakhievitch opened up the patient's brain and, one by one, ablated several thousand neurons, each of which related to the concept of his mother. When the patient woke up from anesthesia, he had lost all notion of his mother. All memories of her, good and bad, were gone. Jubilant with his success, Akakhievitch turned his attention to the next endeavor—the search for cells linked to the memory of “grandmother.”

The story, of course, is fiction. The late neuroscientist Jerry Lettvin (who, unlike Akakhievitch, was real) told it to a crowd of students at the Massachusetts Institute of Technology in 1969 to illustrate the provocative idea that as few as about 18,000 neurons could form the basis of any particular conscious experience, thought or memory of a relative or any other person or object we might come across. Lettvin never proved or disproved his audacious hypothesis, and for more than 40 years scientists have debated, mostly in jest, the idea of “grandmother cells.”

The idea of neurons that store memories in such a highly specific manner goes all the way back to William James, who in the late 19th century conceived of “pontifical cells” to which our consciousness is attached. The existence of these cells, though, runs counter to the dominant view that the perception of any specific individual or object is accomplished by the collective activity of many millions if not billions of nerve cells, what Nobel laureate Charles Sherrington in 1940 called “a millionfold democracy.” In this case, the activity of any one individual nerve cell is meaningless. Only the collaboration of very large populations of neurons creates meaning.

Neuroscientists continue to argue about whether it takes relatively few neurons—on the order of thousands or less—to serve as repositories for a particular concept or whether it takes hundreds of millions distributed widely throughout the brain. Attempts to resolve this dispute are leading to new understanding of the workings of memory and conscious thought—with a little help from Hollywood.

JENNIFER ANISTON NEURONS

SOME YEARS AGO—together with Gabriel Kreiman, now a faculty member at Harvard Medical School, and Leila Reddy, now a researcher at the Brain and Cognition Research Center in Toulouse, France—we performed experiments that led to the discovery of a neuron in the hippocampus of one patient, a brain region known to be involved in memory processes, that responded very strongly to different photographs of actress Jennifer Aniston but not to dozens of other actors, celebrities, places and animals. In another

patient, a neuron in the hippocampus lit up at the sight of pictures of actress Halle Berry and even to her name written on the computer screen but responded to nothing else. Another neuron fired selectively to pictures of Oprah Winfrey and to her name written on the screen and spoken by a computer-synthesized voice. Yet another fired to pictures of Luke Skywalker and to

his written and spoken name, and so on.

This kind of observation is made possible by the direct recording of the activity of individual neurons. Other more common techniques, such as functional brain imaging, can pinpoint activity throughout the brain when a volunteer performs a given task. Yet although functional imaging can track the overall power consumption of typically a few million cells, it cannot identify small groups of neurons, let alone individual cells. To record the electrical pulses emitted by individual neurons, microelectrodes thinner than a human hair need to be implanted in the brain. This technique is used less commonly than functional imaging, and only special medical circumstances warrant implantation of these electrodes in humans.

One of those rare circumstances occurs when treating patients with epilepsy. When seizures cannot be controlled with medication, these patients may be candidates for remedial surgery. The medical team examines clinical evidence that can pinpoint the location of the area where seizures start, the epileptic focus, which can potentially be surgically removed to cure the patient. Initially this evaluation involves noninvasive procedures, such as brain imaging, consideration of clinical evidence and the study of pathological electrical activity—a multitude of epileptic discharges that all occur in lockstep—with EEG recordings made from the patient's scalp. But when it is not possible to accurately determine the location of the epileptic focus with these methods, neurosurgeons may implant electrodes deep inside the skull to continuously monitor in the hospital brain activity over several days and then analyze the seizures observed.

Scientists sometimes ask patients to volunteer for research studies during the monitoring period, studies in which a variety of cognitive tasks are performed as brain activity is recorded. At the University of California, Los Angeles, we have employed a unique technique to record within the skull using flexible electrodes with tiny microwires; the technology was developed by one of us (Fried), who heads the Epilepsy Surgery Program at U.C.L.A. and collaborates with other scientists from

around the world, including Koch's group at the California Institute of Technology and Quian Quiroga's laboratory at the University of Leicester in England. This technique furnishes an extraordinary opportunity to record directly from single neurons for days at a time in awake patients and provides the ability to study the firing of neurons during various tasks—monitoring the incessant chattering that occurs while patients look at images on a laptop, recall memories or perform other tasks. That is how we discovered the Jennifer Aniston neurons and unwittingly revived the debate ignited by Lettvin's parable.

GRANDMOTHER CELLS REVISITED

ARE NERVE CELLS such as the Jennifer Aniston neuron the long-debated grandmother cells? To answer that question, we have to be more precise about what we mean by grandmother cells. One extreme way of thinking about the grandmother cell hypothesis is that only one neuron responds to one concept. But if we could find one single neuron that fired to Jennifer Aniston, it strongly suggests that there must be more—the chance of finding the one and only one among billions is minuscule. Moreover, if only a single neuron would be responsible for a person's entire concept of Jennifer Aniston, and it were damaged or destroyed by disease or accident, all trace of Jennifer Aniston would disappear from memory, an extremely unlikely prospect.

A less extreme definition of grandmother cells postulates that many more than a solitary neuron respond to any one concept. This hypothesis is plausible but very difficult, if not impossible, to prove. We cannot try every possible concept to prove that the neuron fires only to Jennifer Aniston. In fact, the opposite is often the case: we often find neurons that respond to more than one concept. Thus, if a neuron fires only to one person during an experiment, we cannot rule out that it could have also fired to some other stimuli that we did not happen to show.

For example, the day after finding the Jennifer Aniston neuron we repeated the experiment, now using many more pictures related to her, and found that the neuron also fired to Lisa Kudrow, a costar in the TV series *Friends* that catapulted both to fame. The neuron that responded to Luke Skywalker also fired to Yoda, another Jedi from *Star Wars*; another neuron fired to two basketball players; another to one of the authors (Quian Quiroga) of this article and other colleagues who interacted with the patient at U.C.L.A., and so on. Even then, one can still argue that these neurons are grandmother cells that are responding to broader concepts, namely, the two blond women from *Friends*, the Jedis from *Star Wars*, the basketball players, or the scientists doing experiments with the patient. This expanded definition turns the discussion of whether these neurons should be considered grandmother cells into a semantic issue.

Let us leave semantics aside for now and focus instead on a few critical aspects of these so-called Jennifer Aniston neurons. First, we found that the responses of each cell are quite selec-

tive—each fires to a small fraction of the pictures of celebrities, politicians, relatives, landmarks, and so on, presented to the patient. Second, each cell responds to multiple representations of a particular individual or place, regardless of specific visual features of the picture used. Indeed, a cell fires in a similar manner in response to different pictures of the same person and even to his or her written or spoken name. It is as if the neuron in its firing patterns tells us: "I know it is Jennifer Aniston, and it does not matter how you present her to me, whether in a red dress, in profile, as a written name or even when you call her name out loud." The neuron, then, seems to respond to the concept—to any representation of the thing itself. Thus, these neurons may be more appropriately called concept cells instead of grandmother cells. Concept cells may sometimes fire to more than one concept, but if they do, these concepts tend to be closely related.

A CODE FOR CONCEPTS

TO UNDERSTAND the way a small number of cells become attached to a particular concept such as Jennifer Aniston, it helps to know something about the brain's complex processes for capturing and storing images of the myriad of objects and people encountered in the world around us. The information taken in by the eyes first goes—via the optic nerve leaving the eyeball—to the primary visual cortex at the back of the head. Neurons there fire in response to a tiny portion of the minute details that compose an image, as if each were lighting up like a pixel in a digital image or as if they were the colored dots in a pointillist painting by Georges Seurat.

One neuron does not suffice to tell whether the detail is part of a face, a cup of tea or the Eiffel Tower. Each cell forms part of an ensemble, a combination that generates a composite image presented, say, as *A Sunday Afternoon on the Island of La Grande Jatte*. If the picture changes slightly, some of the details will vary, and the firing of the corresponding set of neurons will change as well.

The brain needs to process sensory information so that it captures more than a photograph—it must recognize an object and integrate it with what is already known. From the primary visual cortex, the neuronal activation triggered by an image moves through a series of cortical regions toward more frontal areas. Individual neurons in these higher visual areas respond to entire faces or whole objects and not to local details. Just one of these high-level neurons can tell us that the image is a face and not the Eiffel Tower. If we slightly vary the picture, move it about or change the lighting illuminating it, it will change some features, but these neurons do not care much about small differences in detail, and their firing will remain more or less the same—a property known as visual invariance.

Neurons in high-level visual areas send their information to the medial temporal lobe—the hippocampus and surrounding cortex—which is involved in memory functions and is where we found the Jennifer Aniston neurons. The responses of neurons in the hippocampus are much more specific than in the higher visual cortex. Each of these neurons responds to a particular person or, more precisely, to the concept of that person: not only to the face and other facets of appearance but also to closely associated attributes such as the person's name.

In our research, we have tried to explore how many individual neurons fire to represent a given concept. We had to ask

A single neuron that responded to Luke Skywalker and his written and spoken name also fired to the image of Yoda.

whether it is just one, dozens, thousands or perhaps millions. In other words, how “sparse” is the representation of concepts? Clearly, we cannot measure this number directly, because we cannot record the activity of all neurons in a given area. Using statistical methods, Stephen Waydo, at the time a doctoral student with one of us (Koch) at Caltech, estimated that a particular concept triggers the firing of no more than a million or so neurons, out of about a billion in the medial temporal lobe. But be-

cause we use pictures of things that are very familiar to the patients in our research—which tend to trigger more responses—this number should be taken strictly as an upper bound; the number of cells representing a concept may be 10 or 100 times as small, perhaps close to Lettvin’s guess of 18,000 neurons per concept.

Contrary to this argument, one reason to think that the brain does not code concepts sparsely, but rather distributes them across very large neuronal populations, is that we may not have enough neurons to represent all possible concepts and their variations. Do we, for instance, have a big enough store of brain cells to picture Grandma smiling, weaving, drinking tea or waiting at the bus stop, as well as the Queen of England greeting the crowds, Luke Skywalker as a child on Tatooine or fighting Darth Vader, and so on?

To answer this question, we should first consider that, in fact, a typical person remembers no more than 10,000 concepts. And this is not a lot in comparison to the billion nerve cells that make up the medial temporal lobe. Furthermore, we have good reason to think that concepts may be coded and stored very efficiently in a sparse way. Neurons in the medial temporal lobe just do not care about different instances of the same concept—they do not care if Luke is sitting or standing; they only care if a stimulus has something to do with Luke. They fire to the concept itself no matter how it is presented. Making the concept more abstract—firing to all instances of Luke—reduces the information that a neuron needs to encode and allows it to become highly selective, responding to Luke but not to Jennifer.

Simulation studies by Waydo underscore this view even further. Drawing on a detailed model of visual processing, Waydo built a software-based neural network that learned to recognize many unlabeled pictures of airplanes, cars, motorbikes and human faces. The software did so without supervision from a teacher. It was not told “this is a plane and that a car.” It had to figure this out by itself, using the assumption that the immense variety of possible images is in reality based on a small number of people or things and that each is represented by a small subset of neurons, just as we found in the medial temporal lobe. By incorporating this sparse representation in the software simulation, the network learned to distinguish the same persons or objects even when shown in myriad different ways, a finding similar to our observations from human brain recordings.

CONCEPT CELLS

To Code a Memory

Neuroscientists ardently debate two alternative theories of how memories are encoded in the brain. One theory contends that the representation of a single memory—the image of Luke Skywalker, for instance—is stored as bits and pieces distributed across millions or perhaps billions of neurons. The alternative view, which has gained more scientific credibility in recent years, holds that a relatively few neurons, numbering in the thousands or perhaps even less, constitute a “sparse” representation of an image. Each of those neurons will switch on to the image of Luke, whether from a distance or close-up. Some but not all of the same group of neurons will also fire to the related image of Yoda. Similarly, a separate set of specific neurons activates when perceiving Jennifer Aniston.

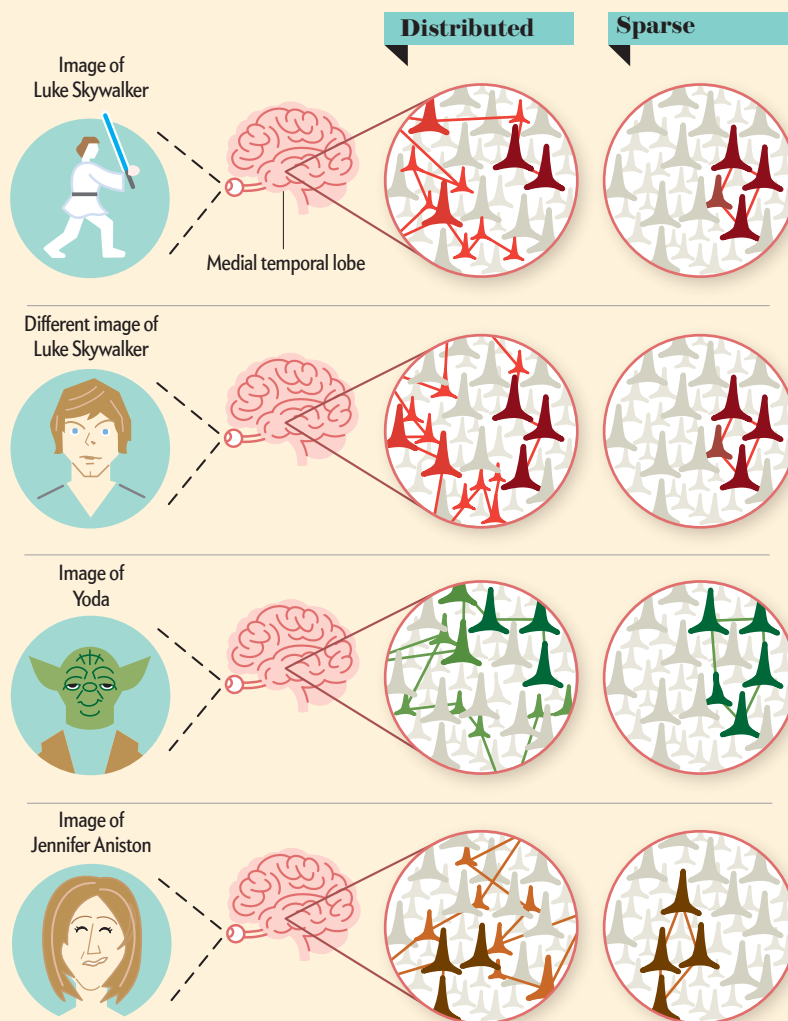

WHY CONCEPT CELLS?

OUR RESEARCH is closely related to the question of how the brain interprets the outside world and translates perceptions into memories. Consider the famous 1953 case of patient H.M., who suffered from intractable epilepsy. As a desperate approach to try to stop his seizures, a neurosurgeon removed his hippocampus and adjoining regions in both sides of the brain. After the surgery, H.M. could still recognize people and objects and remember events that he had known before the surgery, but the unexpected result was that he could no longer make new long-lasting memories. Without the hippocampus, everything that happened to him quickly fell into oblivion. The 2000 movie *Memento* revolves around a character who has a similar neurological condition.

H.M.'s case demonstrates that the hippocampus, and the medial temporal lobe in general, is not necessary for perception but is critical for transferring short-term memories (things we remember for a short while) into long-term memories (things remembered for hours, days or years). In line with this evidence, we argue that concept cells, which reside in these areas, are critical for translating what is in our awareness—whatever is triggered by sensory inputs or internal recall—into long-term memories that will later be stored in other areas in the cerebral cortex. We believe that the Jennifer Aniston neuron we found was not necessary for the patient to recognize the actress or to remember who she was, but it was critical to bring Aniston into awareness for forging new links and memories related to her, such as later remembering seeing her picture.

Our brains may use a small number of concept cells to represent many instances of one thing as a unique concept—a sparse and invariant representation. The workings of concept cells go a long way toward explaining the way we remember: we recall Jennifer and Luke in all guises instead of remembering every pore on their faces. We neither need (nor want) to remember every detail of whatever happens to us.

What is important is to grasp the gist of particular situations involving persons and concepts that are relevant to us, rather than remembering an overwhelming myriad of meaningless details. If we run into somebody we know in a café, it is more important to remember a few salient events at this encounter than what exactly the person was wearing, every single word he used or what the other strangers relaxing in the café looked like. Concept cells tend to fire to personally relevant things because we typically remember events involving people and things that are familiar to us and we do not invest in making memories of things that have no particular relevance.

Memories are much more than single isolated concepts. A memory of Jennifer Aniston involves a series of events in which she—or her character in *Friends* for that matter—takes part. The full recollection of a single memory episode requires links between different but associated concepts: Jennifer Aniston linked to the concept of your sitting on a sofa while spooning ice cream and watching *Friends*.

If two concepts are related, some of the neurons encoding one concept may also fire to the other one. This hypothesis gives a physiological explanation for how neurons in the brain encode associations. The tendency for cells to fire to related concepts may indeed be the basis for the creation of episodic memories (such as the particular sequence of events during the

café encounter) or the flow of consciousness, moving spontaneously from one concept to the other. We see Jennifer Aniston, and this perception evokes the memory of the TV, the sofa and ice cream—related concepts that underlie the memory of watching an episode of *Friends*. A similar process may also create the links between aspects of the same concept stored in different cortical areas, bringing together the smell, shape, color and texture of a rose—or Jennifer's appearance and voice.

Given the obvious advantages of storing high-level memories as abstract concepts, we can also ask why the representation of these concepts has to be sparsely distributed in the medial temporal lobe. One answer is provided by modeling studies, which have consistently shown that sparse representations are necessary for creating rapid associations.

The technical details are complex, but the general idea is quite simple. Imagine a distributed—as opposite of sparse—representation for the person we met in the café, with neurons coding for each minute feature of that person. Imagine another distributed representation for the café itself. Making a connection between the person and the café would require creating links among the different details representing each concept but without mixing them up with others, because the café looks like a comfortable bookstore and our friend looks like somebody else we know.

Creating such links with distributed networks is very slow and leads to the mixing of memories. Establishing such connections with sparse networks is, in contrast, fast and easy. It just requires creating a few links between the groups of cells representing each concept, by getting a few neurons to start firing to both concepts. Another advantage of a sparse representation is that something new can be added without profoundly affecting everything else in the network. This separation is much more difficult to achieve with distributed networks, where adding a new concept shifts boundaries for the entire network.

Concept cells link perception to memory; they give an abstract and sparse representation of semantic knowledge—the people, places, objects, all the meaningful concepts that make up our individual worlds. They constitute the building blocks for the memories of facts and events of our lives. Their elegant coding scheme allows our minds to leave aside countless unimportant details and extract meaning that can be used to make new associations and memories. They encode what is critical to retain from our experiences.

Concept cells are not quite like the grandmother cells that Lettvin envisioned, but they may be an important physical basis of human cognitive abilities, the hardware components of thought and memory. ■

MORE TO EXPLORE

Sparse but Not “Grandmother-Cell” Coding in the Medial Temporal Lobe. R. Quian Quiroga, G. Kreiman, C. Koch and I. Fried in *Trends in Cognitive Sciences*, Vol. 12, No. 3, pages 87–91; March 2008.

Percepts to Recollections: Insights from Single Neuron Recordings in the Human Brain. Nanthia Suthana and Itzhak Fried in *Trends in Cognitive Sciences*, Vol. 16, No. 8, pages 427–436; July 16, 2012.

Concept Cells: The Building Blocks of Declarative Memory Functions. Rodrigo Quian Quiroga in *Nature Reviews Neuroscience*, Vol. 13, pages 587–597; August 2012.

SCIENTIFIC AMERICAN ONLINE

Read an excerpt of Quian Quiroga's book on memory at ScientificAmerican.com/feb2013/brain-cells



SPACE

SECRETS OF PRIMITIVE METEORITES

Microscopic analyses of chondrites, the oldest rocks in the solar system, are filling in details of what our neighborhood in space was like shortly before the planets formed

By Alan E. Rubin

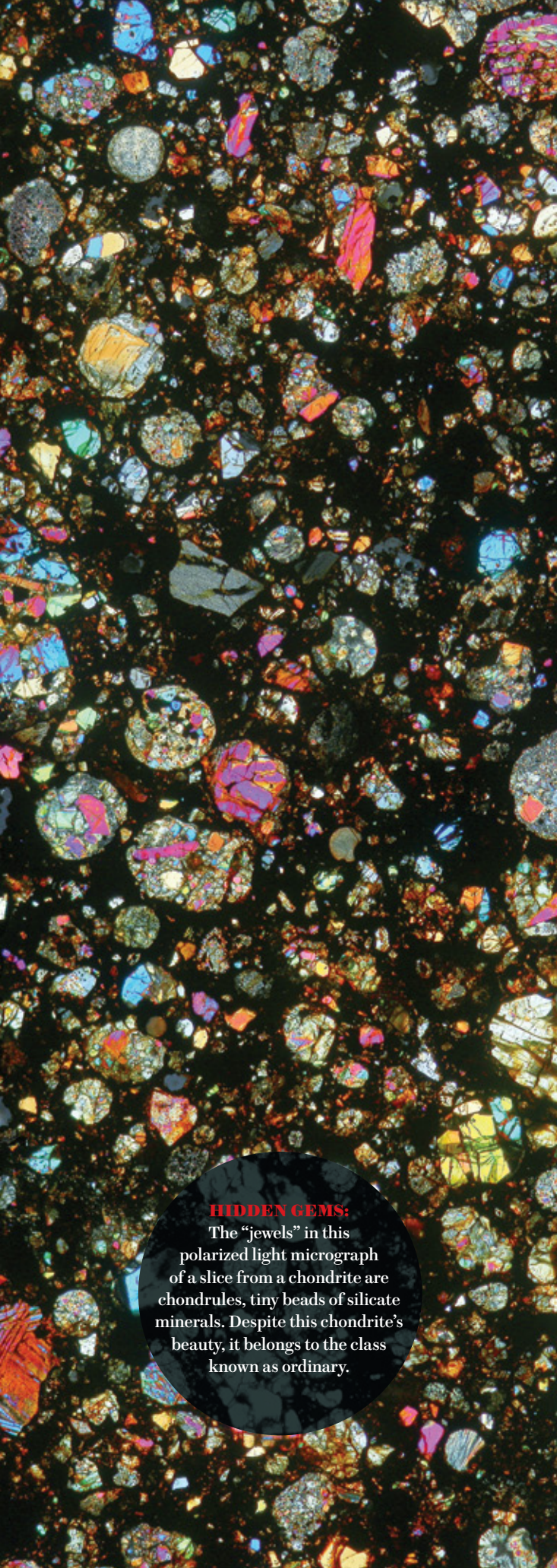

HIDDEN GEMS:

The “jewels” in this polarized light micrograph of a slice from a chondrite are chondrules, tiny beads of silicate minerals. Despite this chondrite’s beauty, it belongs to the class known as ordinary.

I PITY ASTRONOMERS.

They can see the objects of their affection—stars, galaxies, quasars—only remotely: as images on computer screens or as light waves projected from unsympathetic spectrographs. Yet many of us who study planets and asteroids can caress pieces of our beloved celestial bodies and induce them to reveal their innermost secrets. When I was an undergraduate astronomy major, I spent many a cold night looking through telescopes at star clusters and nebulae, and I can testify that holding a fragment of an asteroid is more emotionally rewarding; it offers a tangible connection with what might otherwise seem distant and abstract.

The asteroidal fragments that fascinate me most are the chondrites. These meteorites, which constitute more than 80 percent of those observed to fall from space, derive their name from the chondrules virtually all of them contain—tiny beads of melted material, often smaller than a rice grain, that formed before asteroids took shape early in the solar system’s history. When we examine thin slices from chondrites under a microscope, they become beautiful to behold, not unlike some of the paintings by Wassily Kandinsky and other abstract artists.

Chondrites are the oldest rocks that scientists have ever touched. Radioisotope dating shows that they hark back more than 4.5 billion years to the time before the planets formed, when the solar system was still the turbulent, rotating disk of gas and dust astronomers dub the solar nebula. Their age and composition reveal that they consist of the primordial materials from which the planets, moons, asteroids and comets ultimately assembled. Most researchers believe that chondrules formed

when silicate-rich clumps of dust melted to form individual liquid droplets during highly energetic events. The droplets quickly solidified and accreted—along with dust, metals and other materials—to form chondrites, which later grew to become asteroids. High-speed collisions among asteroids caused them to fragment and chip; eventually some of the debris fell to Earth as meteorites. The tangibility that appeals to me is thus not just a matter of aesthetics—these meteorites are fossils from the birth of the solar system, our firmest links to the conditions under which our own planet Earth took shape.

Yet as anthropologists know, finding fossils is just the first step to reconstructing history. The finds need to be put into a context. Inferring the birthplace of the different chondrites and their environmental cradles, however, has been difficult because we have had surprisingly scant data about the detailed structures of these varied rocks. A few years ago I made a systematic examination of the full range of the physical properties of chondrites, filling in many of the critical gaps that existed. With these data, I constructed a rough map of the structure of the ancient nebula from which the chondrites emerged.

Remarkably, the dust distribution in the map, crude as it is, resembles that of some T Tauri stellar systems. T Tauri objects vary erratically in luminosity and are enshrouded in extensive atmospheres, so they are thought to be young—or “pre-main sequence”—stars. Many of them are surrounded by dusty disks. The concordance of the solar-nebula dust map with the structure of certain T Tauri systems supports the idea that the latter are the progenitors of solar systems like our own. Chondrites thus probe not only our own deep past but offer insight into other young stellar systems in the Milky Way. Likewise, as scientists learn about the physics of these systems, they will better understand the processes that led to the formation of our own asteroids and planets.

CHONDRITE CHARACTERISTICS

TO EXPLORE the primordial solar system by analyzing chondrites, planetary scientists must first have an accurate accounting of the rocks’ properties. Researchers have sorted chondrites into about a dozen basic groups distinguished by such features as their bulk chemical composition; their mix of isotopes (elements with the same number of protons but different numbers of neutrons); the number, size and types of their chondrules; and the amount of compacted dusty matrix in which the chondrules and other materials are embedded. Because each chondrite group has a distinct and narrow range of physical, chemical and isotopic characteristics, different groups that have fallen to Earth must have hailed from separate asteroids. Investigators have concocted many imaginative models to explain how the different chondrite groups initially formed, which involve such processes as gas turbulence, magnetic fields and differences in the velocities at which particles settled to the nebular midplane. The bottom line, however, has

Alan E. Rubin is a geochemist at the University of California, Los Angeles, who studies a wide variety of meteorites. In addition to scientific papers, he has written about 30 popular articles on space science and the book *Disturbing the Solar System* (Princeton University Press, 2002). He notes that asteroid 6227 Alannrubin is mildly eccentric like its namesake, although the latter is more likely to crash into Earth.



often been a vague conclusion that the various kinds of chondrites formed under “different conditions.”

Hoping to gain a better handle on what those conditions were, in 2009 I began digging through the literature with the intention of constructing a table that listed the essential properties of the major chondrite groups. Once I had the table in hand, I intended to search for correlations among the properties that might shed light on the history of each group. But the table I constructed was more than half empty; few researchers, it seemed, had been interested in gathering these kinds of data.

The only option was to do it myself. To that end, I parked myself at a microscope and examined 91 thin sections of 53 different meteorites from different chondrite groups. At a thickness of 30 microns, many minerals become transparent and their optical properties can be studied. The sections reveal a wide variety of chondrules that vary in size, shape, texture and color. Analyzing thousands of chondrules can certainly be tedious, but by persisting in this exercise in “microscopic astronomy,” I managed to fill out the table in just a couple of months. My findings did not fully resolve the “different conditions” conundrum, but the results did extend and refine ideas about where the different chondrite groups originated in the solar nebula and what their local environments were like.

Consider, first, a rare class known as enstatite chondrites that comprises only about 2 percent of all the chondrites observed to fall to Earth. These rocks are named for what typically is their most abundant mineral—enstatite (MgSiO_3)—and they come in two forms, labeled EH and EL for the *high* or *low* amounts of total iron they contain. Scientists have discovered that the abundances of specific isotopes of nitrogen, oxygen, titanium, chromium and nickel in these chondrites resemble those of Earth and Mars, and they have thus surmised that the enstatite chondrites probably formed within the orbit of Mars, appreciably closer to the sun than the inferred locations of other chondrite groups.

A second set, the so-called ordinary chondrites, comprises three separate but closely related groups—labeled H, L and LL—that vary in the amounts and forms of iron they contain. “Ordinary” refers to their prevalence; together they constitute 74 percent of observed meteorite falls. The great abundance of all three groups indicates that they came from a region of the

IN BRIEF

Chondritic meteorites are made of the stuff that formed the planets, moons, asteroids and comets. Each chondrite group has its own distinctive textural and compositional characteristics.

From these properties, the author and other scientists have inferred roughly the locations where the chondrite groups formed and the relative amount of dust present in those regions.

The dust distribution resembles that seen in protoplanetary disks of dust and gas swirling around several stars known as T Tauri stars—in particular, young, one- to two-million-year-old versions

about as massive as our sun. This resemblance suggests that T Tauri systems are good analogues of the sun and its own disk during the early stages of solar system history.

solar system that is gravitationally favorable for delivering meteorites to Earth.

John Wasson of the University of California, Los Angeles, has proposed that the ordinary chondrites hail from a region just sunward of the center of the asteroid belt, situated between the orbits of Mars and Jupiter. Asteroids lying at a distance of 2.5 times Earth's own distance from the sun (2.5 astronomical units) would complete three orbits around the sun in 12 years; Jupiter, lying at a distance of 5.2 astronomical units, completes just one orbit in this same time interval. Such a resonance means that Jupiter's enormous gravity tugs regularly on these asteroids and eventually steers many of them toward the inner solar system. In Sweden, scientists have found dozens of ordinary chondrites in 470-million-year-old rocks—a sign that ordinary chondrites have indeed been pelting Earth for more than 10 percent of our planet's 4.5-billion-year history.

A third group—the rare Rumuruti, or R, chondrites (named for the site in Kenya where the only observed fall occurred)—resembles ordinary chondrites in many of its chemical properties. They have much more matrix material, however, and significantly higher abundances of the oxygen isotope ^{17}O relative to the lighter isotope ^{16}O . High temperatures in the nebula tend to equalize isotopic abundances, and the farther an object gets from the sun, the more likely it is that variations in oxygen isotopes will be preserved. This imbalance in isotopes suggests that the R chondrites formed farther from the sun than ordinary chondrites.

High temperatures also break down organic compounds, which tend to be found more abundantly in the diverse class of meteorites known as carbonaceous chondrites than in other chondrite groups. Thus, carbonaceous chondrites almost certainly orbited at even greater distances from the sun than R chondrites did. The carbonaceous chondrites themselves comprise six major groups that can each be assigned more specific nebular positions on the basis of their chemical, isotopic and structural properties.

DUST TO DUST

APART FROM their chemical composition, the internal structures of chondrites also reveal much about the amount of dust in the immediate environs where they formed. Dust has been crucial in all stages of the solar system's evolution. As the original cloud of material that produced the sun and planets collapsed, dust

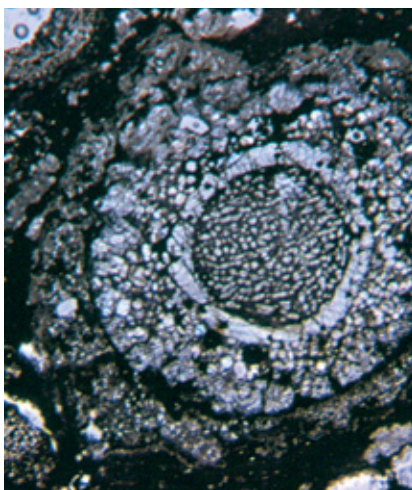

HINTS OF DUST: In certain chondrites, such as the carbonaceous type in the top image, chondrules tend to be large and complex (*micrograph*), containing a silicate core (*central sphere and thin ring around it*) surrounded by a secondary shell (*thick band*) and an outer layer called an igneous rim (*irregular zone*). Shells and rims arise after dust encases an existing chondrule and then melts. The presence of shells and rims indicates, then, that a chondrule evolved in a rather dusty part of the solar nebula; absence signifies less dusty environs.

grains became more effective at trapping infrared radiation; the resulting increase in temperature at the center of the cloud eventually led to the formation of a protostar. Later, dust (and, at greater distances from the center, ice) settled toward the nebular midplane and coagulated into larger clumps, eventually forming porous bodies, known as planetesimals, ranging in size from a few meters to tens of kilometers. Some of these planetesimals melted. The planets ultimately formed from a diverse suite of such melted and unmelted planetesimals; comets and asteroids most likely accreted from unmelted planetesimals having more uniform compositions.

One clue to the abundance of dust at the location where a particular chondrite group formed is the presence of dust-laden shells surrounding a silicate core in chondrules. Chondrules in certain carbonaceous chondrites, for example, commonly include a core, or “primary” chondrule, encased in a secondary spherical shell of melted, or igneous, material similar in composition to the primary chondrule. Frequently the secondary shell is itself surrounded by a tertiary shell termed an igneous rim, which is composed of finer mineral grains than are present in the central core [*see micrograph at left*].

Many meteorite researchers have suggested that the secondary shells were created when some original chondrule, having solidified after the initial melting event, acquired a porous dusty shell and then experienced a second, intermediate-energy event that melted the shell but not the interior chondrule. Subsequently, events of lower energy or shorter duration, or both, produced the igneous rim. Simply put, chondrite groups that contain numerous chondrules displaying the “nested shell” structure appear to have formed in dusty environments.

Multiple remelting episodes interspersed with periods during which the chondrules became enmeshed in dust would naturally produce larger chondrules with a thick secondary shell and thick igneous rim. Thus, the presence of

such features is indicative of a substantial amount of dust in the environment where the chondrules formed. Chondrules encased in dust would also cool off more slowly than others because heat could not radiate away quickly. The relatively slow cooling would have, in turn, facilitated the evaporation of volatile elements, such as sodium and sulfur. Although most of the volatiles would have condensed on nearby dust (ultimately to be incorporated

Our Solar System before Planets

After examining many chemical and structural features in four classes of chondrites (colors), which are divided into 12 major groups (named by initials at bottom), the author refined models of roughly where the 12 originated and inferred the relative amounts

of dust in the vicinity at the time (map; dots indicate likely range of possible locations). He found that the most dust (densest shading) surrounded the CR, CV and CK carbonaceous chondrites, which probably orbited beyond three astronomical units. The dust

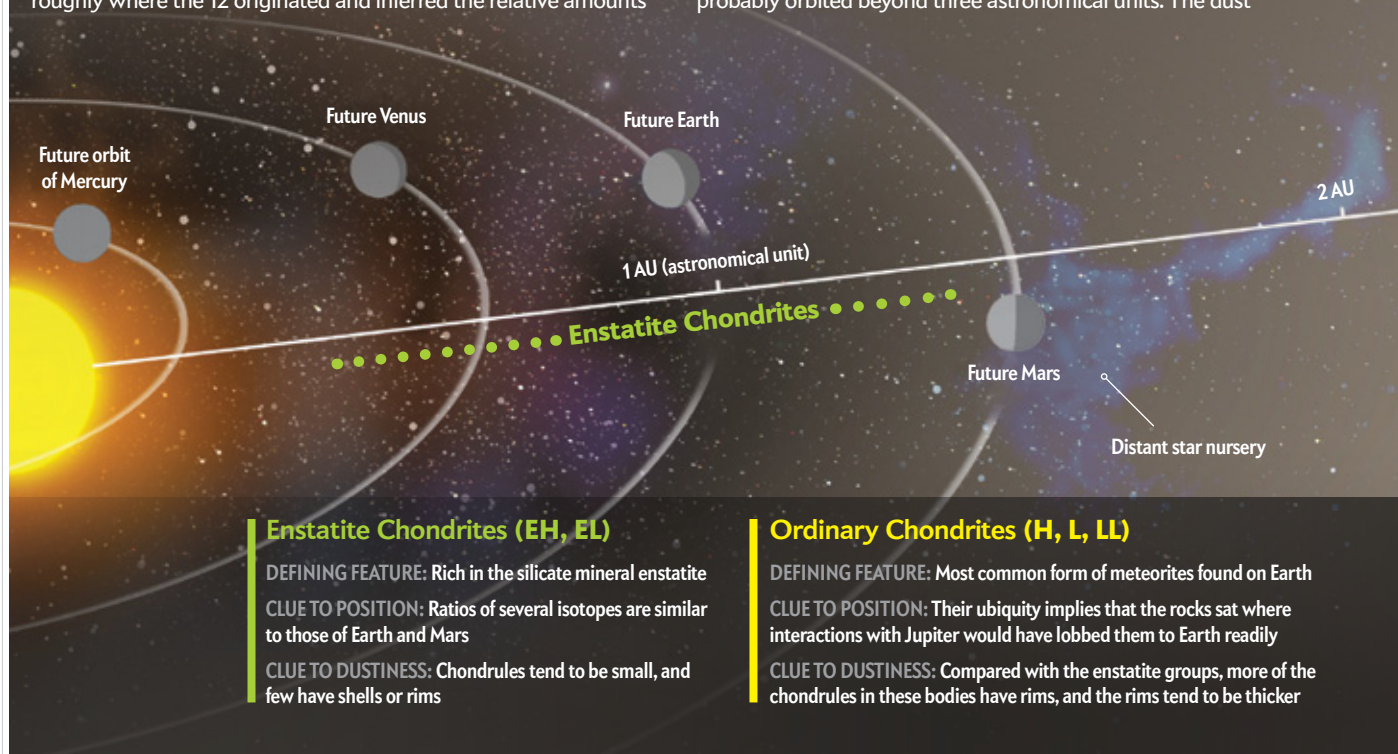

into the chondrites), some fraction of them would have been lost. The sodium and sulfur contents of the chondrite groups containing these large, dust-laden chondrules should therefore be lower than those of chondrite groups whose chondrules formed in dust-poor environments. I found that this is indeed the case.

By combining this and other information with the presumed locations of the parent asteroids, I developed a crude map of dust abundances across the early solar system [see box on these two pages]. The enstatite groups, which presumably formed sunward of Mars's orbit, sat in what must have been a dust-poor region; they have, for instance, few chondrules with shells or rims, and those chondrules that do sport rims have thin ones. The ordinary and R chondrites, which are next farthest from the sun, show more signs of dustiness—for example, the proportion of chondrules with igneous rims is higher and the rims are thicker than in the enstatite groups.

The dust concentration appears to have peaked in the region occupied by the carbonaceous chondrite groups with the largest chondrules and the greatest numbers of chondrules encased in secondary shells and igneous rims (those known as the CR, CV and CK groups). It then tapered off toward the locations of two carbonaceous chondrite groups (CM and CO) even farther from the sun. (Chondrules in these groups are much smaller, and far fewer of them show secondary shells and igneous rims.) The to-

tal amount of dust diminished still farther in the vicinity of the most distant carbonaceous chondrite group (CI), which contains no chondrules at all. (These are true chondrites nonetheless because the main criterion for class admission is having a chemical composition similar to that of the sun's nonvolatile elements.)

The dust distribution in this nebular map led me to conclude that our early solar system was probably similar to many of the T Tauri stars observed today—young stars like the early sun that have not yet settled down to the main business of stable hydrogen burning. The dust pattern resembles published astronomical observations of several protoplanetary disks around T Tauri stars. Because the masses of these particular disks (about 2 percent of the sun's mass) are similar to that inferred for the solar nebula, it seems that the disks provide good models for the nebula during the period of chondrule formation and chondrite assembly.

HEATED DISAGREEMENT

JUST WHAT PROCESSES created chondrules are not yet understood. The first thing that any model of chondrule formation must explain is the evidence for repeated melting. The process must also have been widespread or else it would not have led to chondrules occurring in almost every chondrite group. Unfortunately, no convincing heating mechanism has been found that accounts for all chondrule properties. The multiple melting of so

concentration dropped off farther out, where the CM, CO and, finally, the CI chondrites roamed; it also declined in the other direction, ending up very sparse in the region of the enstatite chondrites. The distribution resembles that of certain young,

T Tauri star systems of today, suggesting that information gleaned about the physics of those systems can reveal something about our own early solar system, and vice versa. The text at the bottom explains part of the logic used to construct this map.

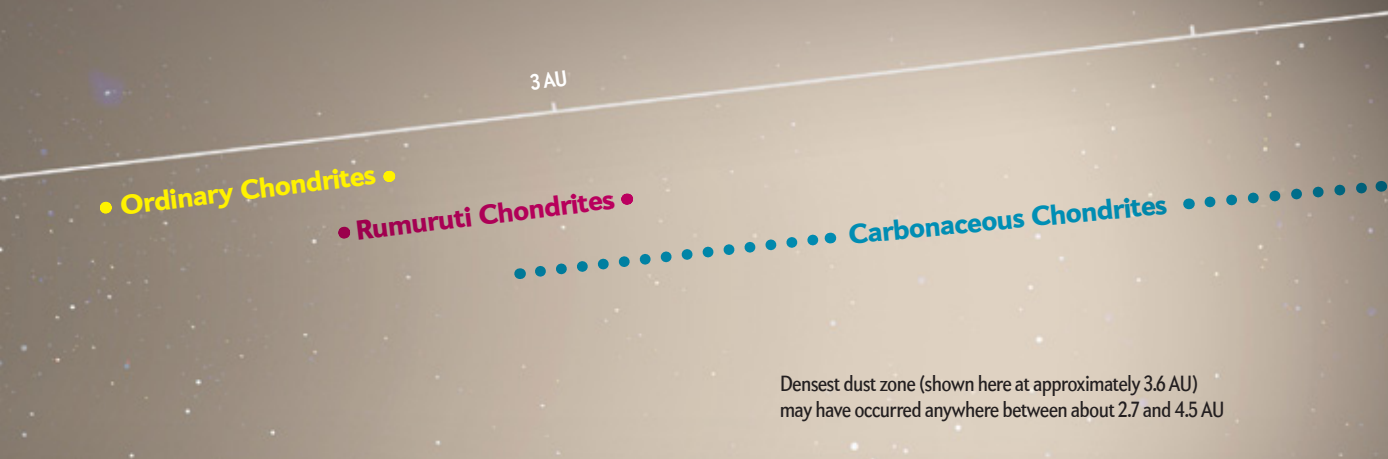

Densest dust zone (shown here at approximately 3.6 AU) may have occurred anywhere between about 2.7 and 4.5 AU

Rumuruti Chondrites (R)

DEFINING FEATURE: Differ slightly in composition from ordinary chondrites

CLUE TO POSITION: Ratios of certain isotopes imply a position farther from the sun than that of ordinary chondrites

CLUE TO DUSTINESS: The proportion of matrix material (fine-grained silicate material between chondrules), derived from nebular dust, is much higher than in ordinary chondrites

Carbonaceous Chondrites (CR, CV, CK, CM, CO, CI)

DEFINING FEATURE: Rich in organic compounds

CLUE TO POSITION: Presence of organics means these meteorites formed far from the sun, which would otherwise have degraded the organic matter

CLUE TO DUSTINESS: CR, CV and CK chondrites have the largest chondrules and the thickest igneous rims; CM and CO groups tend to have smaller chondrules and thinner rims; CI meteorites lack chondrules

many chondrules rules out any of the proposed one-shot phenomena, such as supernova shock waves or gamma-ray bursts from deep space. The heat source must have been capable, on the one hand, of melting some entire chondrules (including ones several millimeters in size) but, on the other hand, of melting just the thin dust mantles around other chondrules while leaving their interiors intact. Some researchers have suggested a repeating, pulsed heat source, such as lightning bolts, but no consensus has been reached on the feasibility of generating lightning in the solar nebula.

The chondrule-formation model currently popular with astrophysicists involves shock-wave heating in the nebula. Shock waves could have been produced, for instance, by material falling into the nebula from outside. Propagation of the shock waves through dusty nebular regions could have produced enough heat to cause chondrule melting. Models relying on shock waves have their own flaws, however. First, shock waves have yet to be observed in protoplanetary disks; their existence is unproved. Second, shocks would heat huge numbers of chondrules at once but seem incapable of melting only the outer surface of individual chondrules (to form secondary shells and igneous rims) while leaving the chondrule interiors relatively cold. A third apparent flaw is that shock waves, which are localized phenomena, seem unlikely to have produced chondrules in widely separated nebu-

lar regions. The principal mechanism for the formation of chondrules thus remains a mystery.

Fifty years ago in these pages, meteorite researcher John A. Wood observed, "Only recently have we begun to study chondrules as entities. They contain a wealth of information ... about the processes that have acted on them. We may be able to learn about the nature and evolution of the solar nebula, the formation of the planets, some stages of the evolution of the sun and the time scales for all these processes." Half a century later scientists still have much to learn, but the picture provided by these primordial messengers of the solar system is at last coming into focus. **SA**

MORE TO EXPLORE

Chemical, Mineralogical and Isotopic Properties of Chondrules: Clues to Their Origin. R. H. Jones, J. N. Grossman and A. E. Rubin in *Chondrites and the Protoplanetary Disk*. Edited by A. N. Krot, E.R.D. Scott and B. Reipurth. Astronomical Society of the Pacific Conference Series, Vol. 341, pages 251–285; 2005.

Physical Properties of Chondrules in Different Chondrite Groups: Implications for Multiple Melting Events in Dusty Environments. Alan E. Rubin in *Geochimica et Cosmochimica Acta*, Vol. 74, No. 16, pages 4807–4828; August 15, 2010.

Meteorite or Meteorwrong? Department of Earth and Planetary Sciences, Washington University in St. Louis: http://meteorites.wustl.edu/id/ordinary_chondrites.htm

SCIENTIFIC AMERICAN ONLINE

View a slide show of chondrites and chondrules at ScientificAmerican.com/feb2013/chondrites

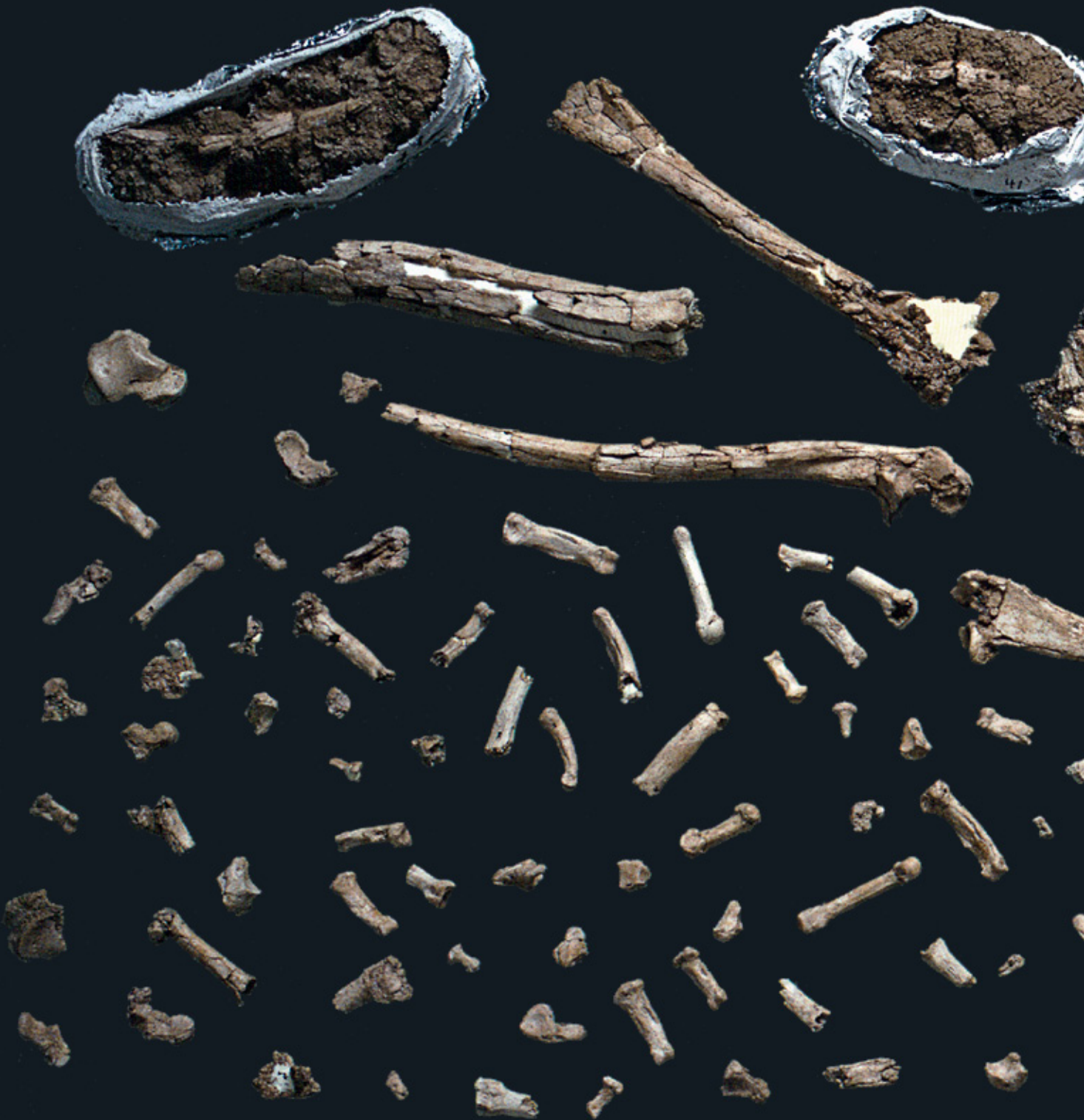

HUMAN EVOLUTION

SHATTERED

New fossil discoveries complicate the already devilish task of identifying

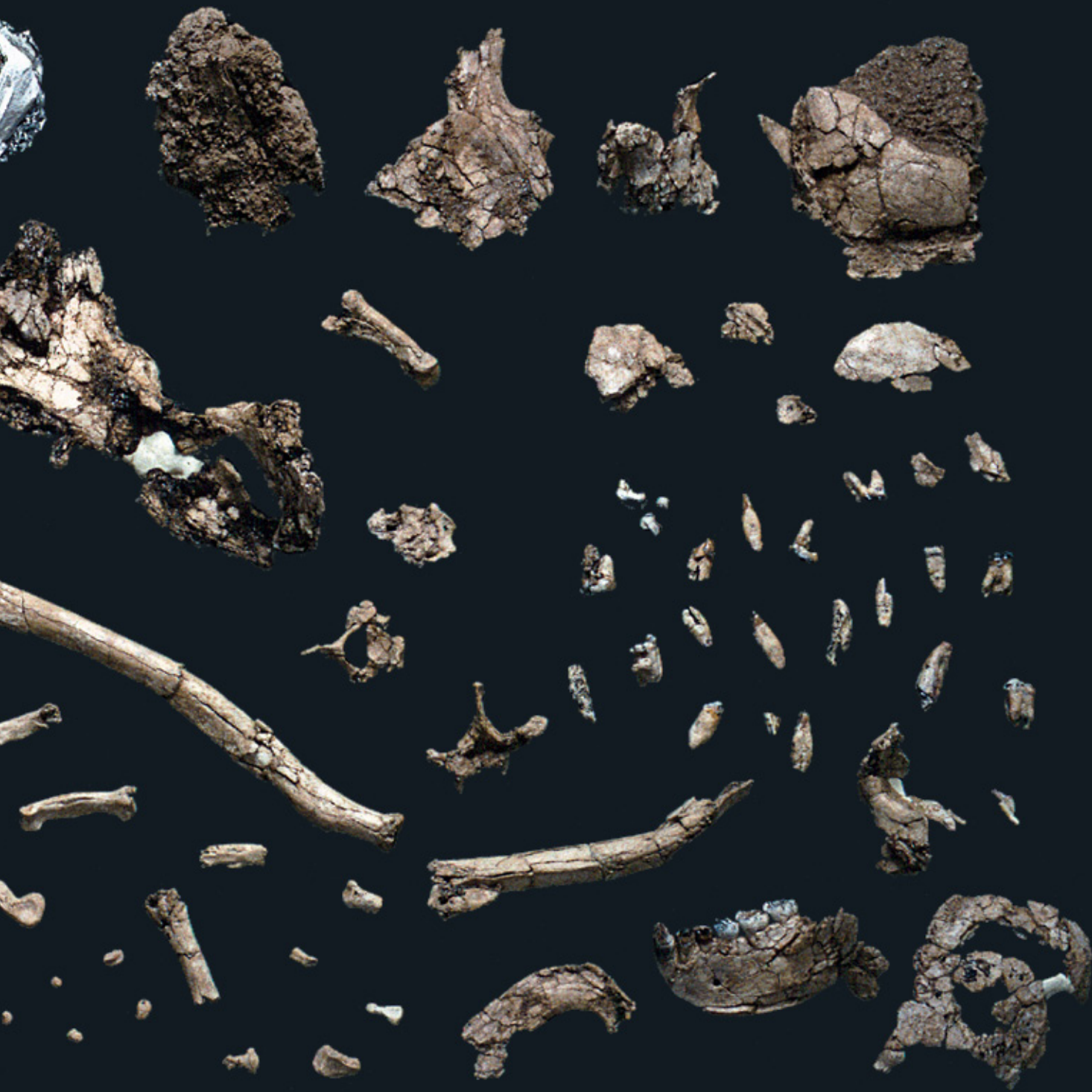

ANCESTRY

our most ancient progenitors

By Katherine Harmon

**PUZZLE
PIECES:**

Fragmented skeleton of *Ardipithecus ramidus* has upended ideas about the earliest humans.

FROM A DISTANCE, YOU PROBABLY WOULD have assumed her to be human. Although she stood only about a meter tall, with long arms and a small head, she walked, if perhaps slightly inelegantly, upright on two legs, as we, alone among living mammals, do. This familiar yet strange individual is Lucy, a member of the species *Australopithecus afarensis*, who lived some 3.2 million years ago. She is one of the oldest creatures presumed to have strode on the evolutionary path leading to our species, *Homo sapiens*.

When Lucy was uncovered in 1974, evidence of bipedal locomotion virtually guaranteed her kind a spot in the human family tree. And although scientists had an inkling that other branches of humans coexisted more recently alongside our own, early human evolution appeared to be a simple affair, with Lucy and the other ancient bipeds that eventually came

to light belonging to the same lone lineage. Thus, the discoveries seemed to uphold the notion of human evolution as a unilinear “march of progress” from a knuckle-walking chimplike ape to our striding, upright form—a schema that has dominated paleoanthropology for the past century. Yet as researchers dig back further in time, our origins are turning out to be a lot more complicated than that iconic image would suggest.

Two recent discoveries are shattering what scientists thought they knew about the rise of humans: one a stunningly complete skeleton from 4.4 million years ago and the other a very fragmentary foot from 3.4 million years ago. The freshly described fossils indicate that we probably came from a convoluted tree of humans—and that the ostensibly human hallmark of upright walking may have developed more than once—and

of humans, of which our species is the sole survivor. **Recent fossil discoveries** have upended that scenario, however, providing intriguing evidence that the last common ancestor of humans and chimpanzees may not have looked particularly chimplike and

in more than one fashion—including in creatures that were not our direct ancestors. Because of these finds, researchers are now reconsidering what traits mark a species as a direct human ancestor, what the pace has been for human evolution and whether it will ever be possible to confidently identify our last common ancestor with chimps.

“The more fossils we get, the more we’re realizing that the evolutionary tree is actually quite bushy,” says Carol V. Ward of the University of Missouri School of Medicine. The remains are also revealing that the human line is not the only one to have undergone astounding adaptations in the past several million years. The chimpanzee lineage, too, has surely changed considerably over that same period, becoming highly specialized for life in the trees—a revelation that may finally lay to rest the abiding notion that living chimpanzees

are a good model for our ancient ancestors. This shift “gives us a whole different perspective on our origins,” Ward says.

SMALL HOMININ, BIG SHIFT

NOTHING THREW as large a wrench into the hunched-ape-to-*Homo* scenario as the petite creature known as Ardi. The description of this remarkably complete 4.4-million-year-old skeleton of *Ardipithecus ramidus* in a ream of papers in 2009 sent paleoanthropology into a tailspin. Uncovered at a site called Aramis in Ethiopia’s Afar region, Ardi looks little like researchers would have expected of a hominin from that time period (hominins are primates more closely related to us than are chimps—our closest living relatives). Many paleoanthropologists anticipated that a hominin dating to that era would have many traits

IN BRIEF

Paleoanthropologists have long thought that humans descended from a chimpanzeelike ancestor and that early human fossils belonged to a single evolving lineage. According to this view, only later did our predecessors diversify into multiple overlapping branches

that our early forebearers were not alone in Africa. **The findings** are forcing researchers to reconsider what traits indicate that a species belongs on the line leading to us—and to question whether it will ever be possible to identify our last common ancestor.



A FOOT APART: Partial fossil foot from the site of Burtele in Ethiopia (*left*) had a divergent big toe and other traits that distinguish it from the feet of modern humans (*right*) and their ancestors, revealing that a second lineage of bipeds might have coexisted with our probable ancestor *Australopithecus afarensis*.

seen in chimps and other modern African apes, including large canine teeth for aggression-based social systems, very long arms and fingers for climbing in trees, and wrist adaptations for knuckle walking, among other features.

Instead the slight *A. ramidus* is what Tim D. White of the University of California, Berkeley, who led the team that discovered Ardi, has described as a “mosaic organism” that possesses characteristics of later hominins and ancient apes—but not so much of chimpanzees. Like humans, Ardi has reduced canine teeth, which researchers think might signify a transition away from a male-dominated social system toward a more cooperative system revolving around pairs who form long-term bonds. Also unlike modern African apes, Ardi’s high degree of wrist extension suggests that when she walked on all fours, she supported her weight on her palms rather than her knuckles. Meanwhile Ardi’s fingers were relatively long and curved—helpful for climbing trees—but her wrists and hands might have prevented her from swinging between branches as capably as chimpanzees do.

Ardi’s lower limbs exhibit a similar combination of human-like and ancient apelike characteristics. Whereas her relatively flat feet and divergent big toe (or hallux) would have aided arboreal locomotion, the stiffness of her foot and her minor toes’ ability to flex backward would have facilitated bipedal walking. Her

pelvis was badly crushed, leaving some details about her leg motion unknown. But William Jungers of Stony Brook University says that from what he can tell, the short distance between Ardi’s hip bone and sacrum (the triangular bone at the base of the spine) is similar to that found in modern humans and other hominins known to have walked upright. Additionally, the foramen magnum, the opening at the base of the skull through which the spinal cord exits, is located quite far forward in Ardi—a trait that many scientists read as an indication of a vertical stance (and possible bipedalism) when she was on the ground. Some researchers, however, wonder whether she was instead only likely to stand upright intermittently, for example, if she needed to hold something in her hands.

With her startling mélange of anatomical features, Ardi has challenged scientists to reconsider how they define a hominin. The term has traditionally implied obligate upright walking. Yet Ardi shows that potential bipedalism does not exclude decent climbing capabilities. Even modern humans have some locomotor flexibility. “I think people forget [what] good climbers modern people are,” Jungers says. We might not be as well suited to swinging from branch to branch as chimps and other apes are, but in many indigenous human cultures, tree climbing is still an important method of gathering food. Moreover,

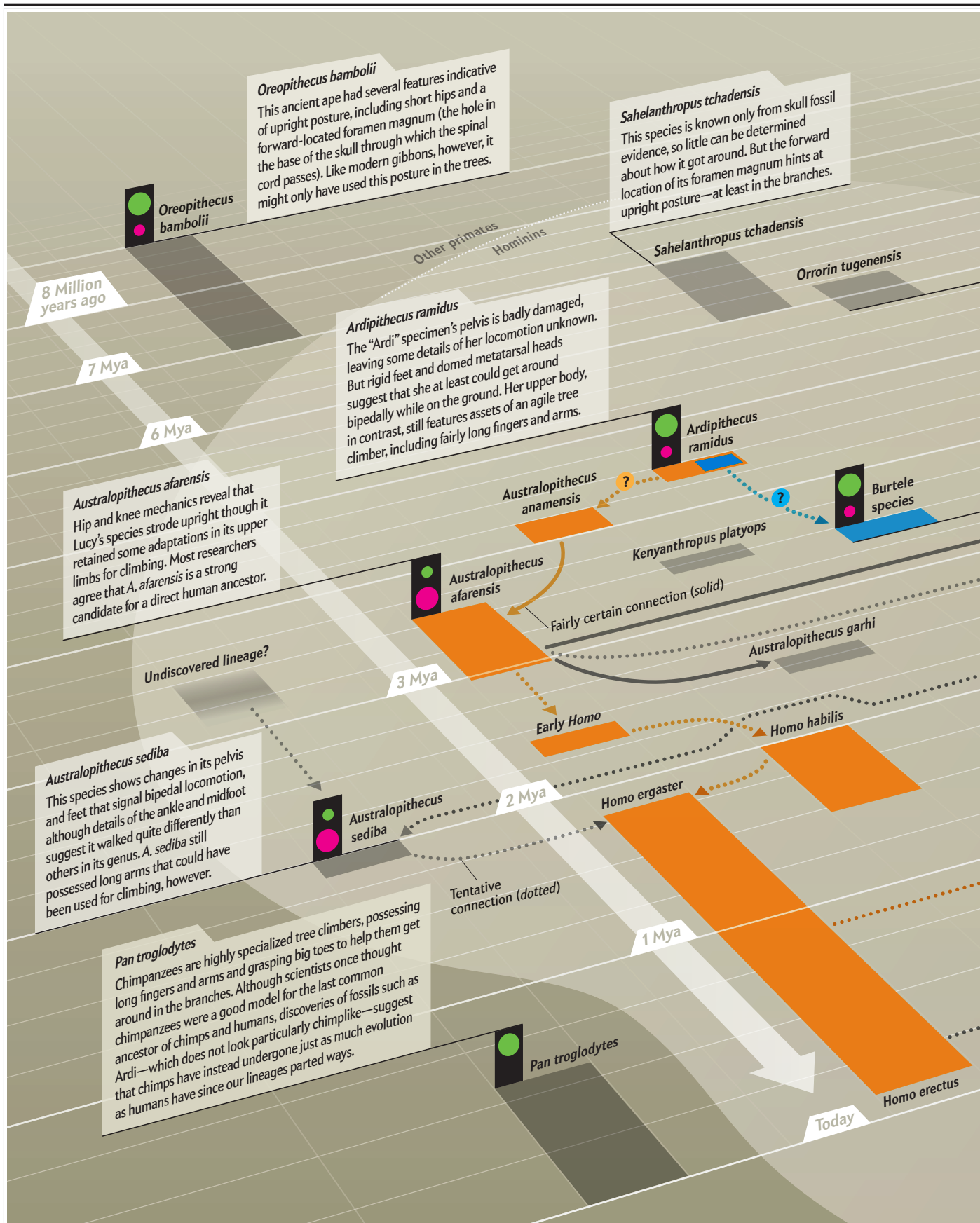

Our Tangled Family Tree

Orrorin tugenensis

Only scattered fossils paint the picture of this animal. But some bones, such as the femur, suggest that this species might have been at least partially adapted for upright walking. Yet its strong arm muscle attachment and curved finger bone seem good for tree climbing.

Butele species

Although only eight bones from this animal have been described, researchers are confident that it represents a new hominin species—one that was still prominently arboreal despite living at the same time as the bipedal *Australopithecus afarensis*, a probable direct ancestor of ours.

The evolution of *Homo sapiens* has long been viewed as a simple, stepwise trajectory that proceeded from a primitive chimplike ape, through a series of intermediary protohumans, and finally to upright and elegant humans. With each station, the features morphed in a single direction: fingers shortened, big toes came into forward alignment, and the head shifted to rest atop a vertical back. New discoveries, however, have shown this “march of progress” picture to be flawed. Fingers have come in all different lengths, diverged big toes (for climbing in trees) have persisted alongside forward-aligned big toes (adapted for upright walking), and even ancient apes show adaptations for walking upright.

This jumble of fossil features emphasizes that evolution is a messy business and hints that early human evolution involved multiple parallel lineages (orange and blue paths) just as later human evolution did. Thus, figuring out which species fossils belong to, along with sorting ancestral lines from dead-end branches, will be harder than was once thought. The illustration on these pages shows how the distribution of some key features related to locomotion in modern and extinct apes and human relatives is complicating the story of our origins.

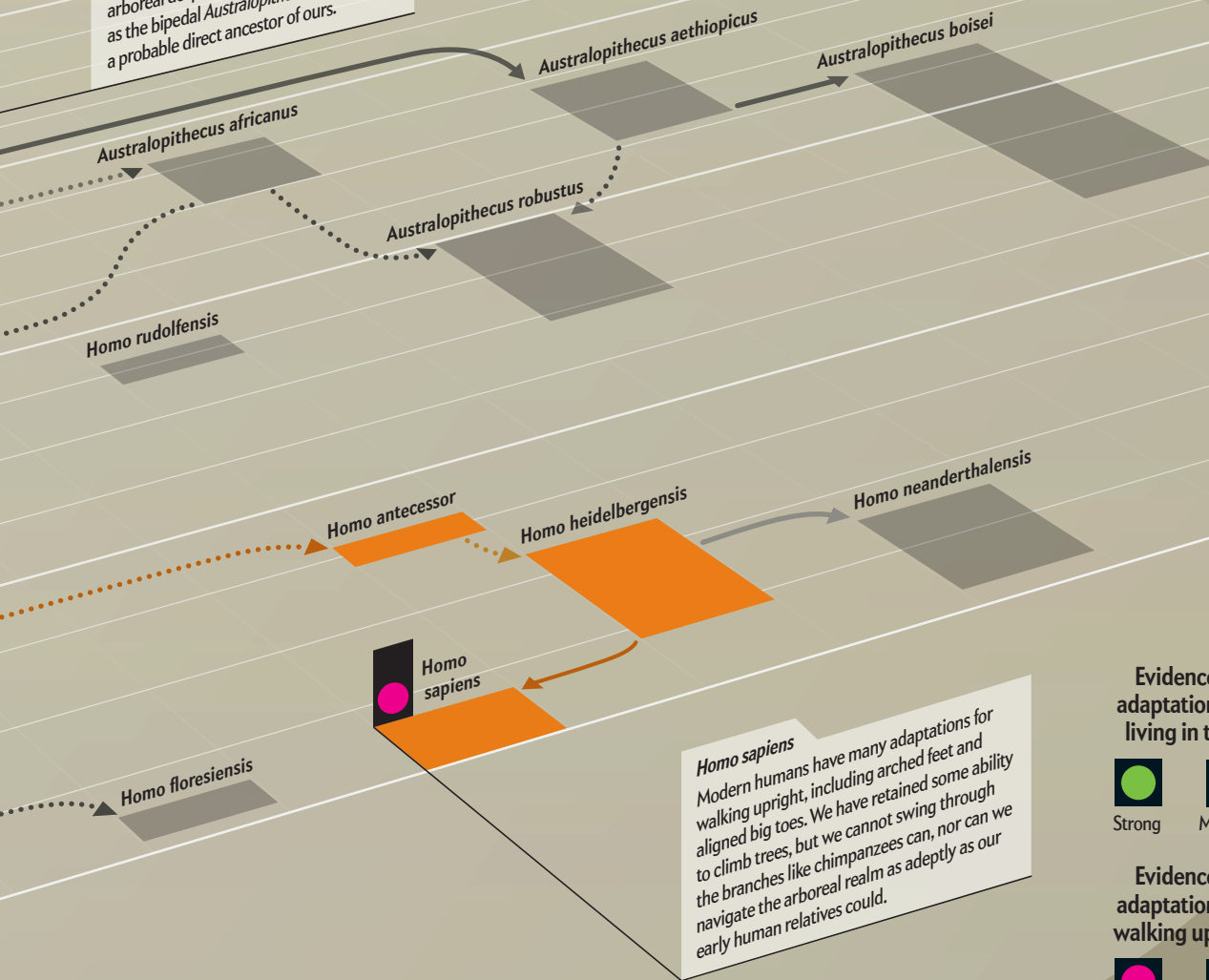

“What we’re glimpsing in the fossil record is but a flicker of the ancient diversity.”

—Carol V. Ward, University of Missouri School of Medicine

Lucy’s species—*A. afarensis*—for all its bipedal ability, retained relatively long arms, suggesting that it might still have occasionally ascended into the trees. A recent analysis of fossils from a young *A. afarensis* found in 2000 in Dikika, Ethiopia, indicates that the species had rather apelike shoulders, which presumably rendered it a proficient climber. So perhaps Lucy, like Ardi and other species that came before and after, had “the best of both possible worlds,” Jungers says.

White and his colleagues have placed *A. ramidus* as a possible ancestor to *A. afarensis*—and therefore as a potential direct forebearer to *H. sapiens*. Given Ardi’s age and other details of her anatomy, however, plenty of researchers suspect she might not be in our direct line. “Ardi may be an early hominin that went off in its own direction,” says David Begun of the University of Toronto. Ardi lived just 200,000 years before a more solidly bipedal species called *Australopithecus anamensis*, which many experts believe to be ancestral to *A. afarensis*. A rapid evolution from *A. ramidus* to *A. anamensis* (eventually leading to *A. afarensis*) might have been possible, but many researchers, including Begun, agree that the more likely explanation is that these species belong not to a single tidy lineage but to two or more different lines. “I think [*A. ramidus*] probably is an evolutionary side branch,” Begun says. Not even Lucy’s place as a direct human ancestor has been settled; the paucity of hominin fossils between the end of *A. afarensis* and the emergence of early *Homo* has kept this question open, notes Yohannes Haile-Selassie of the Cleveland Museum of Natural History, who worked on the 2009 Ardi papers.

Although Ardi’s curious mix of traits—those palm-walking wrists, backward-flexing toes and small canine teeth, for instance—has caused considerable consternation over her place in the family tree, her remains have yielded important insights into human origins precisely *because* she neither resembles a chimp nor fits the traditional conception of a hominin. If she is an early hominin in the line leading to us, then our last common ancestor probably did not look much like a chimpanzee. And if Ardi represents a hominin lineage distinct from our own or perhaps is an extinct ape, then she shows that upright walking is not the defining trait of our line alone. Either way, scientists’ understanding of human evolution gets a shake-up.

COMPANY FOR LUCY

WHILE MANY RESEARCHERS were still reeling from the implications of Ardi, a new anatomical mystery emerged from a site called Burtele, also in Ethiopia’s central Afar region. Described in 2012, this find consists of just eight small foot bones—too few to warrant a new species name but enough for scientists to confidently assert that this specimen is unlike anything seen before. The foot hammers home the idea that hominin evolution was a lot more complex than even Ardi would suggest.

Despite having few bones to tell us about the Burtele speci-

men, Jungers calls it “decidedly hominin,” noting that “the Burtele big toe is a hominin big toe.” Yet this hominin foot is much more archaic than that of an established upright walker such as Lucy’s species. In fact, it resembles Ardi’s foot in having a grasping big toe that points off to the side, suggesting an at least partly arboreal mode of locomotion. This feature might not be so jarring if it were similar in age to Ardi—but it is not. The foot dates to 3.4 million years ago, making its owner a contemporary of *A. afarensis*, which roamed the same region from roughly 3.6 million to 2.9 million years ago.

Like Ardi, the Burtele animal probably walked on the outer edge of its foot when it was upright (avoiding the big toe because it would not propel the walker forward as ours does). Neither creature had yet developed the optimal adaptations for efficient bipedalism, but both could still grasp branches with their feet. Without a medial cuneiform bone (a large bone in the middle of the foot) from Burtele, it is difficult to know how far akimbo its big toe was, notes Jeremy DeSilva of Boston University. Additionally, a knee, pelvis or head would help reveal how the Burtele specimen fits into the apparently complicated story of evolutionary experiments in locomotion.

The Burtele animal might represent a doomed descendant species of *A. ramidus* and an evolutionary side branch that existed, for a time, alongside our own lineage. “You think about Lucy looking up in the tree and seeing these things,” says Bruce Latimer of Case Western Reserve University. “These animals would have bumped into each other.” Indeed, the Burtele site lies only about 48 kilometers from where Lucy was found. The discovery of a fossil that is so suggestive of *not* being a direct ancestor is important, too. “It gives us a much more realistic perspective on our history,” Ward says, adding that “we can learn as much from something sister to us [as we can from] something that might be a direct ancestor—we see what options our ancestors *didn’t* pursue.”

MORE PIECES, HARDER PUZZLE

THE BURTELE FOOT underscores that our status as the only surviving hominin (Neandertals went extinct some 28,000 years ago, and the hobbitlike *Homo floresiensis* died out some 17,000 years ago) is probably the exception in hominin evolution rather than the rule. Just as recent chapters of our evolution featured multiple coeval lineages of hominins, so, too, was the rest of our history most likely littered with different overlapping relatives. Now that researchers have evidence that two very different hominins—the Burtele animal and Lucy—were living at roughly the same time, they are realizing that both new and old homininesque fossils will have to be closely reexamined to determine which species they belong to rather than just being dated and assigned to a reigning hominin of that era. “That’s dissertations—and tons of work,” DeSilva says. But rather than it being a headache, he notes, “that’s incredibly exciting.”

Scientists are also slowly learning that these findings should not be as unexpected as they have been. Ward suggests that “when you find something like the Burtele foot, which is clearly different than *A. afarensis*, in some ways we should say, ‘Of course!’” In the Miocene epoch, between 23 million and five million years ago, hundreds of great ape species lived all over the world. To think that somehow that diversity suddenly disappeared is crazy, Ward says. “What we’re glimpsing in the fossil record is but a flicker of the ancient diversity,” she adds. Unfortunately, however, the variety makes it harder to identify our early direct ancestors and the last common ancestor of humans and chimpanzees. Further complicating matters, chimpanzees and other African apes currently have a poor fossil record.

Will it ever be possible to infer evolutionary relationships precisely enough to construct our family tree with confidence? Possibly not—at least not anytime soon. In a 2011 paper in *Nature*, two anthropologists said the quest may be doomed by homoplasy, in which different species develop similar traits independently. (*Scientific American* is part of Nature Publishing Group.) Independent development means that the presence of a trait, such as walking upright—even in species separated by millions of years—does not guarantee that one species is directly descended from the other. “Shared features can only take you so far in determining evolutionary relationships,” notes biological anthropologist Terry Harrison of the Center for the Study of Human Origins at New York University, co-author of the *Nature* paper with Bernard Wood of George Washington University. For instance, the extinct ape *Oreopithecus bambolii*, which lived in what is now Italy nine million to seven million years ago, had small canine teeth relative to other Miocene apes, a short face, a forwardly placed foramen magnum, and short, broad hips—all features associated with hominins. Yet it is nonetheless assumed to be a primitive great ape rather than an early hominin, partly because of its different style of upright locomotion (which may have been confined to trees—similar to extant gibbons), along with characteristics of its feet, fingers and arms, which appear to have been well adapted to climbing in, and swinging among, tree branches.

The Burtele foot adds evidence for homoplasy in the case of upright walking. “Just like you have multiple forms of climbing and multiple ways of walking on four legs in the primate world, why not a couple of different versions of being bipedal?” DeSilva asks. “Evolution’s pretty clever and comes up with solutions to problems over and over again.” He admits to having been a critic of theories arguing for different types of upright walking in creatures such as the recently discovered *Australopithecus sediba*, a nearly two-million-year-old species from South Africa, which had unique heel, ankle, midfoot and knee anatomy. He initially had assumed that the anatomical variations evident in this species might not result in much more locomotor difference than the variation seen in how various modern humans walk. But the Burtele bones helped to change his mind. “No one’s bones look like that,” he says. “You’re forced to come to the conclusion that there were different strategies—different ways of getting around.”

But this realization is not always comfortable. “Everybody wants to think that humans are special,” Latimer says. But if Ardi and other early hominins possess so many nonchimplike traits and chimps themselves are so highly derived, then our last common ancestor was probably not chimplike. Indeed, it may

have looked more homininlike. Latimer points out that the last common ancestor probably had shorter fingers, like those of *A. ramidus* and *A. afarensis*. It probably also had a brain smaller than a chimp’s. As Jungers notes, chimpanzees appear to have bigger brains than some early hominins.

The challenge of figuring out what the last common ancestor might have looked like and how it moved seems bound to intensify. If the past decade has taught paleoanthropologists anything, it is that the branches of human ancestors most likely will continue to get even more convoluted—especially going back further in time. “It’ll get messy back there,” Latimer says.

ANCESTRAL QUAGMIRE

TO MAKE MATTERS more confusing, the last common ancestor is not going to be a single individual, as DeSilva points out. It is going to be a population—and that population will have cousins, and they will have cousins. “Knowing whether you have the common ancestor without DNA is going to be difficult.”

Advances in genetic analysis of living humans and apes have helped scientists estimate when our last common ancestor with chimps lived. But the window—of six million to 10 million years—is still a large one, and sequencing alone cannot yet reveal what the creature might have looked like. Still, current research is starting to refine estimates of mutation rates, which will narrow the target and help paleontologists home in on geologic deposits of the right age that could potentially yield fossils of the ancestor. And pairing fossil evidence with genetic analysis can move the science forward by fleshing out what changes in the genome separated our line from that of chimpanzees as we first began to diverge.

Yet without the genomes of these ancient hominins, it is difficult to place them on any kind of a family tree—or bramble bush. This endeavor is especially tricky “because these things are more closely related to you and me than anything else living on the planet today,” DeSilva explains. So, for example, trying to figure out what the smallest changes in the shape of a foot bone over time say about the evolutionary relationships of the creatures represented in the fossil record has been, unsurprisingly, quite difficult and often contentious.

Although many researchers suspect they might not ever be able to put together a complete picture of hominin ancestry, that worry is unlikely to stop them from trying. But this ever shifting field will need to brace for more Ardis and many more Burteles that shake the established tree. “Be prepared to be shown that you’re wrong,” DeSilva says. “Embrace it—because it shows that things are much more interesting and surprising.” ■

Katherine Harmon is an associate editor at *Scientific American*. Her book about octopuses will be published this fall by Penguin’s Current imprint. Sharon Begley provided additional reporting for this article.

MORE TO EXPLORE

Ardipithecus ramidus and the Paleobiology of Early Hominids. Tim D. White et al. in *Science*, Vol. 326, pages 64 and 75–86; October 2, 2009.

A New Hominin Foot from Ethiopia Shows Multiple Pliocene Bipedal Adaptations. Yohannes Haile-Selassie et al. in *Nature*, Vol. 483, pages 565–569; March 29, 2012.

SCIENTIFIC AMERICAN ONLINE

See a video about the earliest humans at ScientificAmerican.com/feb2013/ancestor



CLIMATE

RETHINKING THE



RED-HOT: Gulf Stream water (*red*) is the warmest in this infrared image of the Atlantic; yellow, green, blue and purple zones are progressively cooler.

GULF STREAM

It's the flow of warm tropical water across the Atlantic that keeps European winters mild, right? Maybe not

By Stephen C. Riser and M. Susan Lozier

IN BRIEF

Three new climate studies indicate that our long-held belief about the Gulf Stream's role in tempering Europe's winters may not be correct. Yet the studies themselves do not agree. **Two of the three studies** ascribe a surprisingly large

role to the direction of the prevailing winds, and one focuses on the heat lost from the ocean. **Many climate models** indicate that extensive melting of Arctic ice would not actually shut down the Gulf Stream, as previously thought.

The ocean's influence on climate in Europe and elsewhere should become clearer within a decade, now that a global array of more than 3,000 floating ocean sensors called Argo is making near-real-time maps of temperature and salinity down to 2,000 meters.

Stephen C. Riser is a professor of oceanography at the University of Washington. He is also a long-standing member of both the U.S. Argo Consortium and the international Argo Steering Team.



M. Susan Lozier is a professor of physical oceanography at the Nicholas School of the Environment at Duke University and is part of the U.S. Atlantic Meridional Overturning Circulation Science Team.



FOR A CENTURY, SCHOOLCHILDREN HAVE BEEN TAUGHT THAT THE MASSIVE OCEAN CURRENT KNOWN AS THE GULF STREAM

carries warm water from the tropical Atlantic Ocean to northwestern Europe. As it arrives, the water heats the air above it. That air moves inland, making winter days in Europe milder than they are in the northeastern U.S.

It might be time to retire that tidy story. The explosion of interest in global climate has prompted scientists to closely study the climatic effects of the Gulf Stream only to discover that those effects are not as clear as conventional wisdom might suggest. Based on modeling work and ocean data, new explanations have emerged for why winter in northern Europe is generally less bitter than winter at the same latitudes in the northeastern U.S. and Canada—and the models differ on the Gulf Stream's role. One of the explanations also provides insight into why winter in the U.S. Northwest is warmer than it is across the Pacific in eastern Russia.

At the same time, recent studies have been casting doubt on the popular conjecture made a few years ago that melting of Arctic ice could “shut down” the Gulf Stream, thereby wreaking havoc with Europe's weather. Yet the studies do suggest that climate change could at least affect the *strength* of the Gulf Stream, which could lessen the impact of global warming on northern Europe.

COMPETING THEORIES

CLIMATE VARIATIONS ACROSS the globe stem primarily from the earth's spherical shape. Because the sun's rays are more perpendicular to the earth's surface at lower latitudes, they impart more heat per unit area there than at higher latitudes. This differential heating leads to the prevailing atmospheric winds, whose instabilities redistribute that heat from the tropics to the poles. The oceans, covering 70 percent of the earth, also play a major role in this redistribution. The upper two meters of the oceans store more solar heat than the entire atmosphere above the seas be-

cause the specific heat (a property that determines the capacity to store heat) of a cubic meter of water is about 4,000 times greater than the same volume of air (and about four times larger than it is for soil). Water temperatures in the upper 100 to 200 meters of the oceans at midlatitudes might vary by 10 degrees Celsius over a year, storing and releasing an immense amount of heat compared with the atmosphere or the land. And because ocean currents, such as the Gulf Stream, move water around the globe, heat gained in the summer at one locale can later be released to the atmosphere thousands of kilometers away.

Given that movement and the oceans' ability to store heat, it is easy to hypothesize that ocean currents might be responsible for the fact that winter air temperatures in Ireland, at about 50 degrees north latitude, are nearly 20 degrees C warmer than they are at the same latitude across the Atlantic in Newfoundland. Similarly, air temperatures at 50 degrees north latitude in the eastern Pacific, near Vancouver, are about 20 degrees C warmer than they are at the same latitude at the southern tip of Russia's Kamchatka Peninsula.

In the 19th century geographer and oceanographer Matthew Fontaine Maury was the first to attribute the relatively mild climate of northwestern Europe to the Gulf Stream. This powerful ocean current flows northward along the southeastern U.S. coast, a product of warm waters from the subtropics and tropics. At about the latitude of Cape Hatteras, N.C., the Gulf Stream turns to the northeast and flows out into the Atlantic. Maury surmised that the Gulf Stream supplies heat to the overlying westerly winds that move across the Atlantic toward northwestern Europe. He also speculated that if the Gulf Stream were somehow diminished in strength, the winter winds would be much colder and that Europe would experience Arctic-style winters. Over the years Maury's idea became almost axiomatic—and until recently, it also remained largely untested.

PRECEDING PAGES: COURTESY OF PETER MINNETT AND BOB EVANS, University of Miami/NOIS/NASA

A decade ago, however, Richard Seager of Columbia University's Lamont-Doherty Earth Observatory and his colleagues produced an explanation for Europe's warmer winter that had nothing to do with the Gulf Stream. Seager's modeling study indicated that when the atmospheric jet stream, which flows around the earth from west to east, hits the Rocky Mountains, it begins to oscillate north and south. The oscillation produces winds that flow from the northwest over the western side of the Atlantic basin and from the southwest over the Atlantic's eastern side. The northwesterly winds bring cold continental air to the northeastern U.S., whereas the southwesterly ones bring warm maritime air to northwestern Europe.

In this view, it is not heat carried by the Gulf Stream that moderates the European climate. Instead heat that is stored off the shores of Europe, in the upper 100 meters of the ocean during the summer, is released to the atmosphere in winter when the southwesterly winds mix the surface ocean waters. In this scenario, the classic conjecture of Maury is incorrect: large-scale wind patterns directed by mountain ranges, plus local storage of heat by the ocean near Europe, set the temperature differences between the western and eastern sides of the Atlantic [see box on next two pages].

It is important to keep in mind that Seager's model simulations did not explicitly take into consideration the transport of heat by the ocean, a point addressed in a study released soon after Seager's by Peter Rhines of the University of Washington and Sirpa Häkkinen of the NASA Goddard Space Flight Center. They put forth a counterargument that offered some modern support for Maury's historical ideas. After examining archived sea-surface temperature data, the two oceanographers concluded that the amount of heat stored in the upper layer of the eastern Atlantic Ocean at the latitudes of northern Europe is enough to maintain mild air temperatures only through December of an average year. The additional heat required to moderate the climate over the remainder of the winter had to be imported from elsewhere. The most likely source: the north-eastward-flowing Gulf Stream.

Measurements showed that at 35 degrees north latitude—roughly the latitude of North Carolina—the North Atlantic transports about 0.8 petawatt of heat northward, mostly by the Gulf Stream. Yet at 55 degrees north latitude—the latitude of Labrador in Canada—this poleward heat transport is negligibly small. Where does all the heat go? Rhines and Häkkinen suggested that it is released by the ocean into the atmosphere along the path of the Gulf Stream. The prevailing winds then carry the heat eastward, where it moderates the European climate. Rhines and Häkkinen essentially argued for Maury's Gulf Stream conjecture, and Seager argued against it, focusing on the role of the atmospheric jet stream.

In 2011 Yohai Kaspi, now at the Weizmann Institute of Science in Rehovot, Israel, and Tapio Schneider of the California Institute of Technology unveiled a third idea, based on novel numerical experiments of the atmosphere and the ocean. They suggested a degree of truth in both the Seager and Rhines scenarios but concentrated mostly on patterns of atmospheric pressure. Kaspi and Schneider's model indicated that the loss of heat from the ocean to the atmosphere along the path of the Gulf Stream where it leaves the U.S. East Coast generates a stationary, atmospheric low-pressure system to the east—on the European side of the At-

lantic. It also creates a stationary high-pressure system to the west—over the eastern edge of the North American continent. For complex reasons, the net result of this pattern is that the stationary low-pressure system delivers warm air to western Europe via the jet stream's southwesterly winds, which pick up heat released all winter long by the Gulf Stream. The stationary high pulls in cold air from the Arctic, cooling eastern North America and increasing the contrast in temperature between North America and Europe.

Thus, the difference in the climate across the Atlantic arises not only because western Europe warms but also because eastern North America gets colder. Both regions have their characteristic temperatures because of the atmospheric circulation pattern established by heat loss from the ocean in the vicinity of the Gulf Stream.

The amount of heat loss from the Gulf Stream that is required to establish this circulation cannot be sustained only from heat that the mid-Atlantic gains during the summer, however. Heat transported by the Gulf Stream, from lower latitudes, is also needed. In this sense, Kaspi and Schneider lend some credence to Maury's earlier ideas. Although the atmospheric low- and high-pressure systems are created without any need to invoke the influence of the Rockies on the jet stream, this new work does highlight the importance of the southwesterly winds in bringing warmth to Europe.

Interestingly, the Kaspi-Schneider model can also explain why western Oregon, Washington State and British Columbia have much milder winters than what Kamchatka endures. This transpacific contrast has never been attributed to the presence of the Kuroshio, the counterpart of the Gulf Stream in the Pacific, primarily because the Pacific is a much larger ocean and the Kuroshio is a considerably weaker current than the Gulf Stream across much of it. Yet the Kaspi-Schneider result would suggest that heat lost over the Kuroshio could induce a stationary, atmospheric-pressure system similar to the one near the Gulf Stream in the Atlantic. The system would deliver cold polar air to northwestern Asia via northwesterly winds there, and southwesterlies would deliver warmer air to the northern U.S. Pacific Coast.

SHUTTING DOWN THE GULF STREAM

THE JURY is still out on which model is correct, although the Kaspi-Schneider scenario seems plausible. The second part of Maury's conjecture—that a cessation of the Gulf Stream would lead to more intense winters over northwestern Europe—has also recently generated considerable interest. For many years the nature of the Gulf Stream's role in climate change has been framed as this question: If a warmer climate melts Arctic ice, will the excess freshwater that enters the ocean in the northern Atlantic decrease the overturning circulation there, shut down the Gulf Stream and rob northwestern Europe of an important source of heat?

The overturning circulation consists of warm upper waters in the North Atlantic that move northward toward the pole and of cold deep waters that move southward toward the equator. These shallow and deep currents link to form something of a conveyor belt by the sinking, or downwelling, of surface waters at high latitudes in the Labrador and Nordic seas and by deep water elsewhere in the global basin that rises, or upwells, to the surface. In

Why Winter Is Warmer in Europe

A century-old explanation says that warm Gulf Stream water makes Europe's winters milder than those at the same latitude on the North American side of the Atlantic. But competing new explanations emphasize the jet stream (prevailing winds) and Arctic air.

New Theory 1: Jet Stream

An oscillating jet stream heads from the southwest toward Europe. The winds churn the ocean's warm surface, releasing heat that was stored in the water during the summer.

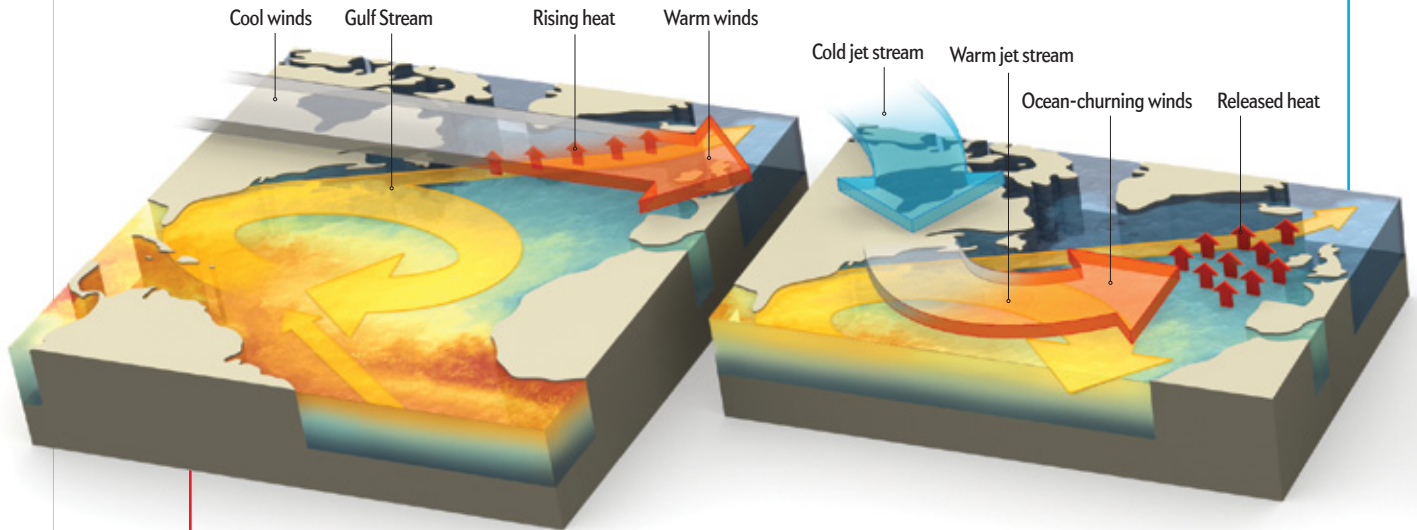

The Classic Story, Incorrect

The Gulf Stream carries warm tropical water toward the southeastern U.S. and then crosses the Atlantic Ocean toward Europe. According to the old theory, as the water arrives near Europe, it heats the air above it. Winds move that mild air inland.

essence, the cold waters that sink in the northern North Atlantic are replaced by relatively warm surface waters that upwell elsewhere in the global ocean.

In many climate-warming scenarios, the melting of Arctic ice would add a large quantity of freshwater to the ocean at high latitudes. Because freshwater is less salty (and thus less dense) than seawater, it might not sink—so the downwelling that feeds the deep currents of the overturning circulation would be inhibited. In this case, there would be no physical requirement for warm deep waters to rise up elsewhere because there would be no downwelling to compensate for; in consequence, with no new warm water rising to the surface, the northward flow of such water—the Gulf Stream—might be diminished. Alternative scenarios hold that freshwater additions at high latitudes would divert the Gulf Stream farther south or diminish its strength. In either case, a weakened or diverted Gulf Stream would provide less heat for European winters. Many models strongly predict that a decrease in the overturning circulation correlates with a subsequent cooling in the North Atlantic and northwestern Europe.

Yet recent modeling studies with higher resolution of ocean currents suggest that fresh Arctic meltwater may pour mostly into currents that are more restricted to the coastlines and therefore have less influence on the open ocean, where downwelling

primarily occurs. Even if freshwater significantly affected the amount of waters downwelled in the North Atlantic, it turns out to be highly unlikely that this change would effectively shut down the Gulf Stream. A shutdown is unlikely because the path and the strength of the Gulf Stream depend largely on the speed and direction of the large-scale midlatitude winds. In most climate change scenarios, the general direction of the large-scale winds does not change significantly as Arctic ice melts, so the general path and strength of the Gulf Stream do not change much either. The northeastward extension of the Gulf Stream—the relatively small branch that brings the warm upper waters to the subpolar regions—could potentially be disrupted, however. Thus, the weight of evidence indicates that the Gulf Stream would persist, but it is unclear how much Gulf Stream water would be carried northward under different climate scenarios.

MORE DATA, BETTER RESOLUTION

AT PRESENT, answers to how climate change would affect Europe's weather come largely from modeling experiments. Still, the experiments have considerable uncertainties that can be reconciled only with more extensive data from the oceans. Few observations from the open oceans are older than a century, and we have satellite data for just the past 30 years or so.

Scientists have recently been making considerable progress

Theory 2: Heated Winds

The Gulf Stream releases heat to the atmosphere along its path across the Atlantic. The jet stream carries the heat eastward, where it moderates Europe's temperatures.

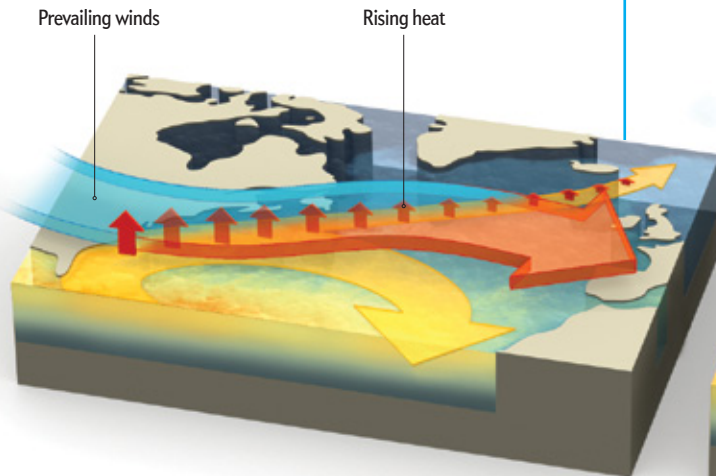

Theory 3: Pressure Systems

Heat released along the Gulf Stream generates stationary atmospheric high-pressure (H) and low-pressure (L) systems. The pressure systems direct warm prevailing winds toward Europe and also draw in cold prevailing winds from the Arctic that cool eastern North America, which accentuates the temperature difference between the continents.

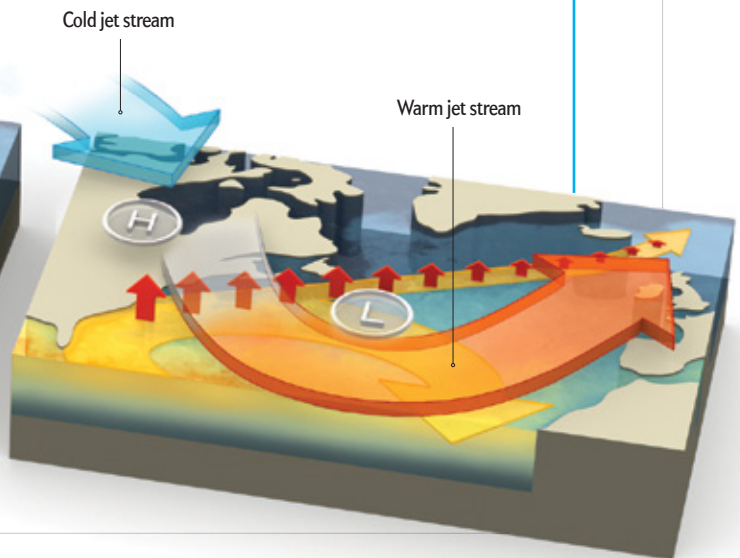

in improving the oceanic database through the Argo project, an ongoing global collection of temperature and salinity measurements from more than 3,000 floating sensors scattered worldwide. The Argo array, deployed and operated by the U.S. and more than 30 other countries, allows scientists to make near-real-time maps of temperature and salinity in the upper 2,000 meters of the world's oceans. The complete array has been in place for less than a decade, and we are just beginning to use it to effectively examine the connection between atmospheric variability and changes in the large-scale ocean.

For example, a comparison of the Argo data with ocean observations from the 1980s, carried out by Dean Roemmich and John Gilson of the Scripps Institution of Oceanography, shows that the upper few hundred meters of the oceans have warmed by about 0.2 degree C in the past 20 years. Upper-ocean salinity also increased globally by a small 0.1 percent—yet below a few hundred meters, ocean waters appear to be considerably fresher than in previous decades. Whether these changes are enough to alter the climate in Europe or anywhere else remains an open question, but the data we are now getting from Argo offer some clues. For the earth to neither warm nor cool, the input of heat from the sun must equal the amount of heat radiated from the earth back into space. Accumulating greenhouse gases in the atmosphere are apparently upsetting this equilibrium. The

observed warming of 0.2 degree C in the upper ocean is consistent with an excess of incoming solar radiation over outgoing radiation of approximately one watt per square meter.

Early results from our improved ocean observatory provide a powerful input for climate theories and models. The results also offer a hint at what will be possible in the coming decades. In the next 10 years, as scientists examine, in tandem, the sea-surface data from satellites, computer models and longer, subsurface data records from Argo, they should be able to assess the role of the ocean in climate with new precision. At that point, we may finally be able to determine how the Gulf Stream will affect climate change on our watery planet. **SA**

MORE TO EXPLORE

Is the Gulf Stream Responsible for Europe's Mild Winters? R. Seager et al. in *Quarterly Journal of the Royal Meteorological Society*, Vol. 128, No. 586, pages 2563–2586; October 2002.
The 2004–2008 Mean and Annual Cycle of Temperature, Salinity, and Steric Height in the Global Ocean from the Argo Program. Dean Roemmich and John Gilson in *Progress in Oceanography*, Vol. 82, No. 2, pages 81–100; August 2009.
Winter Cold of Eastern Continental Boundaries Induced by Warm Ocean Waters. Yohai Kaspi and Tapio Schneider in *Nature*, Vol. 471, pages 621–624; March 31, 2011.

SCIENTIFIC AMERICAN ONLINE

For more details about the Argo ocean array of 3,000 floating sensors worldwide, see ScientificAmerican.com/feb2013/riser

ENGINEERING

THE BATTERY-PO

Few petroleum-powered cars have ever surpassed 400 miles per hour.
Now a group of students plans to do it in an electric vehicle

By Gregory Mone

WERED BULLET



ELECTRIC FLASH:
The Buckeye Bullet 2.5
hit 307 miles per hour
on Utah's Bonneville
Salt Flats in 2010.

Gregory Mone writes about science and technology for publications that include the *Atlantic*, *Discover* and *Popular Science*. He is also the author of four books.



AS HE WAS WALKING TO A MATH CLASS DURING HIS freshman year at Ohio State University, R. J. Kromer spotted a poster for a student-run team designing a fuel-cell-powered car. He had never built anything more complex than Lego-based robot kits, but he sent an e-mail to the group asking to join anyway. To his surprise, the team members responded immediately. “I thought there would be all kinds of requirements,” Kromer recalls, “but they said, ‘No, just show up.’”

So Kromer headed over to the team’s work space at the school’s Center for Automotive Research (CAR). He quickly learned that the unique tribe of mostly baby-faced engineers behind the Buckeye Bullet vehicles, a series of world-record-breaking alternative-fuel cars, planned to test his dedication first. Kromer started out in the engineering equivalent of the

mail room. For the first few months he was mostly sweeping the shop or arranging and organizing various tools and spare parts. Between custodial tasks, though, senior team members started teaching him about wiring, control systems, and more. Soon he was learning more in the shop than he was in class. The next year two seniors graduated, and Kromer was in charge of electrical engineering. “It turns out if you’re willing to not sleep, you can pick up on things pretty fast,” he says.

The Buckeye Bullet team is filled with similar stories. Team leader David Cooke joined by chance as a freshman. Senior engineer Evan Maley joined as a wide-eyed high school student who liked fast cars. Cooke says that in evaluating new volunteers, the team does not look for IQ scores so much as a willing-

ness to work. Kromer’s voluntary insomnia is a group hallmark. Bullet engineers often watch dawn creep in below the 30-foot-tall garage bay doors at the end of their shop. They sleep on conference room floors and, occasionally, test tracks. They spurn the average student’s beer-doused weekend in favor of cutting metal, testing batteries and designing custom suspension systems.

These are not suspension systems on go-karts. This group has produced several of the fastest alternative-fuel vehicles in history. The hydrogen fuel-cell car that drew

Kromer’s interest averaged a top speed of 286 miles per hour in 2008. Two years later the team remodeled it into a battery-powered racer that surpassed 300 mph. And in September of this year, on the Bonneville Salt Flats outside Wendover, Utah, the group contends that its redesigned vehicle will be the first electric racer to crack 400 mph.

Only nine gasoline-powered, wheel-driven cars have ever gone that fast. “The jump from 300 to 400 is huge,” Cooke says. As the car approaches 400 mph, aerodynamic drag increases geometrically. The motors demand more current, which means more batteries and added weight in a vehicle that needs to be as light as possible. Finally, the tires will spin so fast that centrifugal forces threaten to rip them apart. The challenges are

IN BRIEF

The Buckeye Bullet team at Ohio State University is building what it hopes will be the first electric vehicle to break 400 miles per hour, something only nine gas-powered cars have done.

Earlier iterations of the vehicle have already set electric-vehicle speed records, but crossing to 400 mph requires that the team invent solutions to a host of engineering problems.

Among the challenges: generating enough power from the four electric motors, tweaking the aerodynamics to keep the car fast but stable, and making sure the tires don’t blow apart.

If all goes as planned, the team will make its attempts at breaking the 400-mph barrier during test runs this coming September on Utah’s Bonneville Salt Flats.

PRECEDING PAGES: COURTESY OF BARRY HATHAWAY AND THE CENTER FOR AUTOMOTIVE RESEARCH, OHIO STATE UNIVERSITY

formidable enough to discourage a team of veteran engineers, let alone a band of grad students and college kids.

FAST DESIGN

IN 1993 GIORGIO RIZZONI, now director of CAR, assembled the first student team to compete in a short-lived collegiate racing series for battery-powered cars. The team's vehicle, the Smokin' Buckeye, won most of its races, but within a few years the series was cancelled, and Rizzoni figured that would be the end of the program. Instead two of his students informed him that they had struck a sponsorship deal with a local company. They wanted to build the fastest electric car in history. "I looked at the students and said, 'You are positively insane,'" Rizzoni recalls.

Over the next decade the team built three world-record-breaking vehicles. Now Rizzoni rarely questions the team members' lofty goals or engineering or deal-making skills. When Cooke and the team decided they wanted to break the 400-mph barrier, they knew they would need to veer off the standard funding avenues. So they appealed to Gildo Pallanca Pastor, the then 45-year-old owner of Venturi Automobiles, an electric vehicle manufacturer based in Monaco. Pastor, a former amateur racer, the head of a Monaco real estate empire and a restaurateur, had been tracking the team for several years. In 2010 he signed a sponsorship deal to back the quest for 400 mph.

Two years later, on a humid Wednesday last August at CAR headquarters, an inauspicious two-story building with a brick facade at the front and several cavernous hangars at the back, the bearded, 26-year-old Cooke explains that the overall design of the car is nearly settled. The Venturi Buckeye Bullet 3 (VBB3) will be 38 feet long, with four-wheel drive. Because the power required to accelerate the car to 400 mph would be too great for one motor, the team plans to divide the task among four of them. Each motor will generate 400 horsepower, 1,600 in total.

Cooke and several others have been collaborating with Venturi engineers on a custom motor design. The Bullet engineers outlined the ideal dimensions, performance specifications and other details, and they have been iterating designs with the Venturi team for a year. Pastor has already begun road testing a scaled-down version of the Bullet's motor in Venturi's America model, an electric sports car with a top speed of 124 mph. The four Bullet motors will be slightly longer and more powerful, but they will not be finished for a few weeks.

For now, though, the motors are not the main concern. At CAR, the graduate and undergraduate students on the VBB3 team, including Cooke, Maley and a dry-witted 23-year-old engineer named Ling Wang sit in the same small office. When Maley and Cooke step inside, Wang is flipping around a 3-D model of the car's vertical tail fin on his screen. Wang is the aerodynamics expert, and aerodynamics is arguably the biggest challenge in jumping from 300 to 400 mph. The power required to overcome aerodynamic drag is proportional to the cube of the desired velocity. So if you want to double your speed, you need roughly eight times the power.

Cary Bork, a former team member who had just left to take a job at Boeing, spent two years fine-tuning the VBB3's aerodynamic shell, changing the shape and adding drag-reducing features such as spoilers to cover the wheels. The Bullet will have a steel frame and a carbon-fiber shell with a strong but lightweight core made in part from Nomex, a flame-resistant fiber.

The Shape of Speed

When race cars go into wind tunnels, the designers place a rotating belt under the vehicles to accurately model the interaction between the car and the ground. But most belts only work up to 150 mph. So the Buckeye Bullet team is doing all of its aerodynamic modeling using computational fluid dynamics (*top and middle*). The narrow design of the new Bullet is made possible by flat "pouch" battery modules (*bottom*).

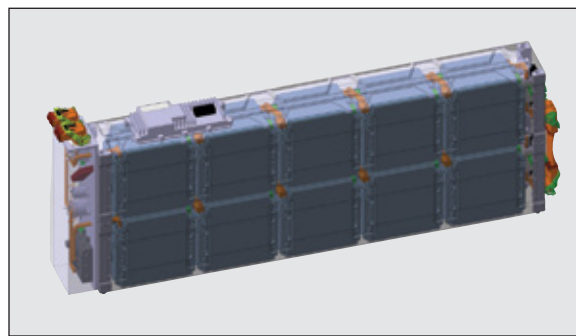
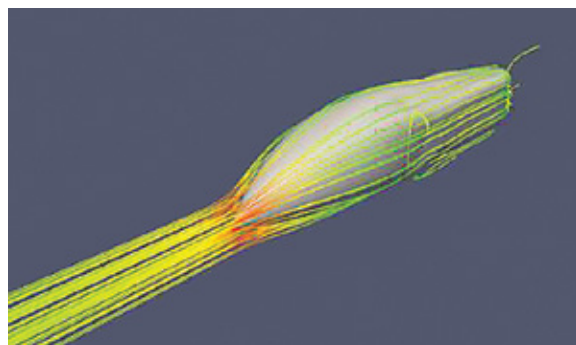

Yet a few big questions remain. Today Wang is focused on the tail fin.

Anything that juts out of the car will add drag, but the team has to have a tail fin to protect the safety of the test driver, a 62-year-old racer named Roger Schroer. All the aerodynamic forces acting on a vehicle can be averaged to a single point, known as the center of pressure. When this point is toward the rear and the vehicle's center of mass is closer to the front, the two balance each other out and keep the vehicle on a straight-line course even with a side wind. The VBB3 will have multiple parachutes and, as a backup, a set of aircraft brakes, but neither

Inside an Electric Rocket

This third iteration of the Buckeye Bullet is being redesigned from scratch, with a shell of carbon fiber and a steel driver chassis modified from an IndyCar design. A prominent tail fin adds stability—especially in case of crosswinds—but it adds aerodynamic drag. Power comes from 80 custom-designed battery modules and four electric motors, each producing 400 horsepower. After the run, a set of at least three parachutes will slow the vehicle; aircraft-grade brakes will serve as a backup in case of emergency.

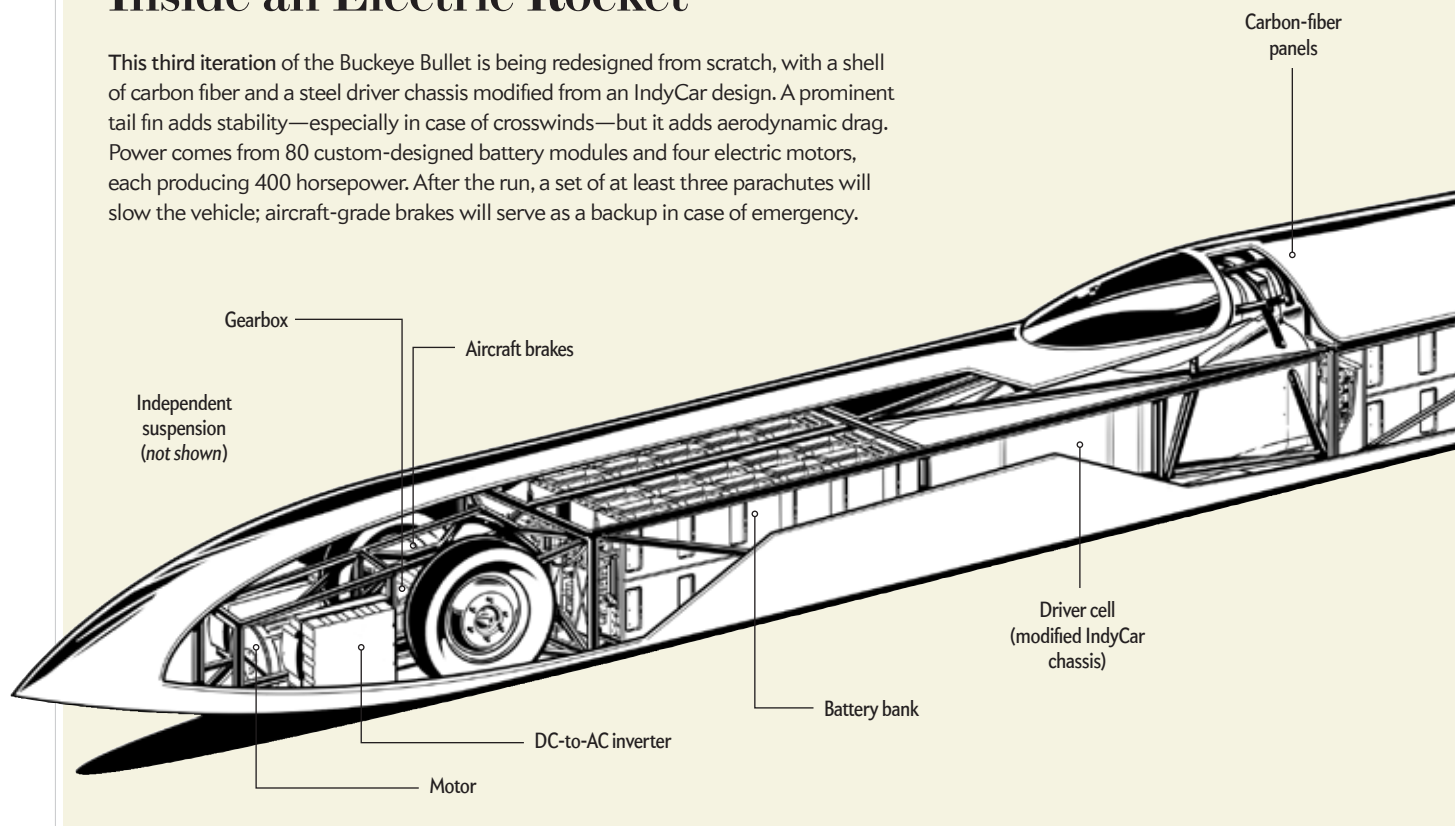

would help Schroer in the event of a spin. “At the end of the day,” Cooke says, “Roger’s life is the most important thing.”

The question is how to strike a balance between aerodynamics and safety. With rapid mouse clicks, Wang picks apart the tail and spins it around in the virtual 3-D space. He switches from a flat design that comes to a point at the top to something resembling the end of a dolphin’s tail—a horizontally oriented fin mounted atop an otherwise vertical one. Maley explains that the team is trying to figure out a way to add a GPS unit and two cameras—one facing the front, the other looking back—to capture data during the run. Wang added the horizontal fin to house all three, then sent his revision to Bork at Boeing.

The new addition, Wang informs them, has just been “Borked.” This is the team’s shorthand for when Bork rejects a change on the grounds that it will add too much drag. “He’s telling us, ‘You’re making the car go slow, so don’t do it,’” Cooke explains.

Slightly annoyed, Wang clarifies: “I knew it was going to make it slower,” he says. “But how much slower?”

As Wang goes back to the model, Cooke turns to another challenge, the batteries. Earlier in the day he showed off several of CAR’s battery-testing chambers. Inside, custom programs repeatedly deplete and charge up battery cells, all while modulating the environmental conditions. This gives CAR’s engineers a better sense of a battery’s true performance, which does not always match the advertised specifications. For the past year Cooke and the group have been rigorously testing a prototype iron nanophosphate lithium-ion battery from the now defunct

manufacturer A123 Systems. On race day, the Bullet will have to finish at least two runs to earn an official world record, and at the end of each 60-second sprint, Cooke notes, the batteries need to be completely depleted. “We want to get all the energy out of a battery in one run,” he says. “If we leave any extra energy in, that means we carried extra weight in batteries.”

The A123 batteries, designed in part by two former Bullet team members who worked at the company, not only store more charge than anything else on the market, they also do it in a tighter package. Cooke explains that standard cylindrical cells, such as the ones they used on their last racer, take up too much space. The circular cross section leaves gaps when you pack them together. That added space translates into more overall volume and a larger car, which means a thicker aerodynamic profile and, in the end, less speed.

Cooke takes a black box reminiscent of a car battery down from a shelf next to his desk, along with a thin, flat, silver square package that could pass for an ice pack. These pouch-type batteries generate more current from a smaller volume. Each one of the black modules will hold 25 pouch cells, with one packed next to the other without gaps, and the savings relative to cylindrical batteries will be enormous, given that there will be 80 of these modules in all. “You’re cutting off a third of the weight and volume,” Cooke says. “This is above and beyond the best that’s out there.”

This challenge of packaging extends beyond the batteries. The vehicle design process is largely about cramming as much

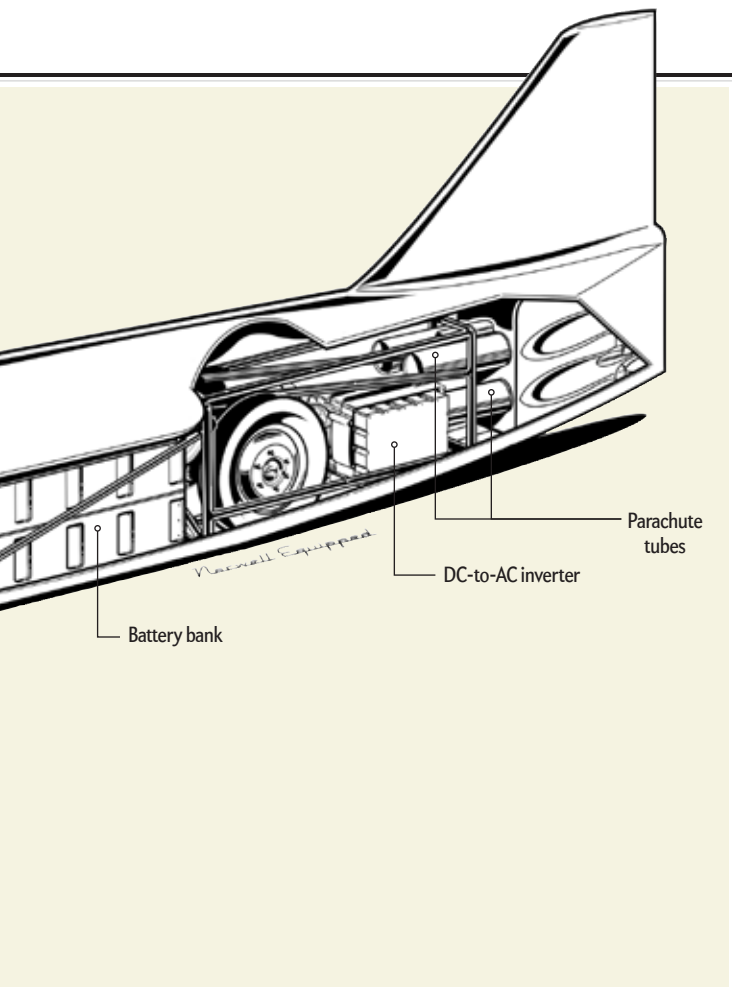

COUNTDOWN TO LAUNCH

THREE MONTHS LATER, in early November, the team is just two months from beginning construction. Maley has redesigned the suspension to lower the motors and the car's center of gravity, but the tail remains a point of debate. As a safety precaution, the team is now considering including three or even four braking parachutes. These extras risk making the rear of the vehicle too large, increasing drag. "The number of parachutes is floating right now," Wang admits.

A month before, the battery supplier A123 had gone bankrupt, but luckily the company's Bullet alumni pushed the project's batteries out the door. "We have all our stuff from them, plus some spares," Cooke says.

The motors are also complete, albeit in slightly revamped form. After further simulation tests, Venturi engineers suggested the motors might not be able to provide enough power. Cooke was hardly discouraged, though. "We've learned that you can't just accept no," he says. "You need to ask why. Why can't we pull any more power? Is it that you can't physically run any more current through the copper windings?" Further digging revealed that the problem was, in fact, related to temperature. According to the simulations, the motors were going to overheat. So Cooke, Maley and fellow undergraduate Luke Kelm worked with Venturi to redesign the motor's cooling system. They changed the flow of the oil-based coolant so that it will come into contact with the motor at more points, thereby enabling it to draw out more heat and keep the temperature down.

This is the legacy of the Bullet project: less a set of technological innovations, impressive though they may be, than a commitment to understanding the limits of existing technology to overcome them. "It's a fantastic exercise," Venturi's Pastor says. "When you have to push components to their limit, you can discover new things and push your ideas in a different way."

Ultimately these challenges provide an unparalleled education, producing a uniquely experienced set of graduates. The Bullet program has produced 50 engineers over the years, and most have gone on to prime jobs in the automotive manufacturing, aerospace and battery-technology sectors. "They are better engineers because they have dealt with these complex problems," Pastor notes.

Kromer, the former freshman who joined on a whim, says he has earned an education that goes far beyond what he learned in class. The kid who did not know a thing about cars has spent the past two years designing the electronic brains of the vehicle, a system that monitors the performance of every component and syncs it all with the driver's controls. Still, Kromer and the others are not just doing it for the lessons. At their core, they are still college kids, and the prospect of breaking that 400-mph barrier in September looms large. "We could break an international speed record," he says. "How many people coming out of college get to say that?" ■

MORE TO EXPLORE

Driving to Mach 1. Gary Stix in *Scientific American*, Vol. 277, No. 4, pages 94-97; October 1997.

The Buckeye Bullet: www.buckeyebullet.com

SCIENTIFIC AMERICAN ONLINE

Watch the previous iteration of the Buckeye Bullet break 320 miles per hour at ScientificAmerican.com/feb2013/bullet

as possible into as narrow a space as possible. Across from Cooke's workstation, for example, Maley's monitor displays a virtual rendition of the suspension system. Record-breaking speedsters often forgo suspension to save weight. Because the driver will have only one mile to accelerate the vehicle, however, Maley and the team decided that they will need traction over every inch of that mile. A bump in the salt flats that causes the wheels to spin, even momentarily, could result in a loss of precious power. Maley explains later that the shocks for the suspension were originally going to be set below the motor and transmission. He is now in the process of revising that design. After considering the overall packaging, he saw that the shocks would have shifted the vehicle's center of gravity upward. "When you think about the transmission and motor weights, you're talking about a few hundred pounds," he says. "You want to keep that weight as low as possible for stability."

Next, Cooke heads out to the shop, a long, open warehouse that also houses various other student-run CAR projects. At the Bullet's station, Cooke grabs a tire with just one-sixteenth of an inch of rubber. He explains that as the vehicle passes 300 mph, the tires will spin so fast that centrifugal force will cause them to expand. The more rubber, the more mass and the greater the force trying to rip that mass apart. A thinner tire means less mass and less chance of the tire disintegrating at high speeds. The catch is that the vehicle will be cruising on a fairly rugged salt flat. "Will the tires make it?" Cooke asks aloud. "That's one of the things that keeps me up at night."



MEDICINE

The Myth *of* Antioxidants

The hallowed notion that oxidative damage causes aging and that vitamins might preserve our youth is now in doubt

By Melinda Wenner Moyer



Melinda Wenner Moyer is a science writer and frequent contributor based in Brooklyn, N.Y. She is also an adjunct assistant professor at the City University of New York Graduate School of Journalism.



DAVID GEMS'S LIFE WAS TURNED UPSIDE DOWN IN 2006 BY A GROUP OF WORMS THAT kept on living when they were supposed to die. As assistant director of the Institute of Healthy Aging at University College London, Gems regularly runs experiments on *Caenorhabditis elegans*, a roundworm that is often used to study the biology of aging. In this case, he was testing the idea that a buildup of cellular damage caused by oxidation—technically, the chemical removal of electrons from a molecule by highly reactive compounds, such as free radicals—is the main mechanism behind aging. According to this theory, rampant oxidation mangles more and more lipids, proteins, snippets of DNA and other key components of cells over time, eventually compromising tissues and organs and thus the functioning of the body as a whole.

Gems genetically engineered the roundworms so they no longer produced certain enzymes that act as naturally occurring antioxidants by deactivating free radicals. Sure enough, in the absence of the antioxidants, levels of free radicals in the worms skyrocketed and triggered potentially damaging oxidative reactions throughout the worms' bodies.

Contrary to Gems's expectations, however, the mutant worms did not die prematurely. Instead they lived just as long as normal worms did. The researcher was mystified. "I said, 'Come on, this can't be right,'" he recalls. "'Obviously something's gone wrong here.'" He asked another investigator in his laboratory to check the results and do the experiment again. Nothing changed. The experimental worms did

not produce these particular antioxidants; they accumulated free radicals as predicted, and yet they did not die young—despite suffering extreme oxidative damage.

Other scientists were finding similarly confounding results in different lab animals. In the U.S., Arlan Richardson, director of the Barshop Institute for Longevity and Aging Studies at the University of Texas Health Science Center in San Antonio, genetically engineered 18 different strains of mice, some of which produced more of certain antioxidant enzymes than normal and some of which produced fewer of them than normal. If the damage caused by free radical production and subsequent oxidation was responsible for aging, then the mice with extra antioxidants in their bodies should have lived

longer than the mice missing their antioxidant enzymes. Yet "I watched those goddamn life span curves, and there was not an inch of difference between them," Richardson says. He published his increasingly bewildering results in a series of papers between 2001 and 2009.

Meanwhile, a few doors down the hall from Richardson, physiologist Rochelle Buffenstein has spent the past 11 years trying to understand why the longest-living rodent, the naked mole rat, is able to survive up to 25 to 30 years—around eight times longer than a similarly sized mouse. Buffenstein's experiments have shown that naked mole rats possess lower levels of natural antioxidants than mice and accumulate more oxidative damage to their tissues at an earlier age

IN BRIEF

For decades researchers assumed that highly reactive molecules called free radicals caused aging by damaging cells and thus undermining the functioning of tissues and organs.

Recent experiments, however, show that increases in certain free radicals in mice and worms correlate with longer life span. Indeed, in some circumstances, free radicals seem to signal cellular repair networks.

If these results are confirmed, they may suggest that taking antioxidants in the form of vitamins or other supplements can do more harm than good in otherwise healthy individuals.

than other rodents. Yet paradoxically, they live virtually disease-free until they die at a very old age.

To proponents of the long-standing oxidative damage theory of aging, these findings are nothing short of heretical. They are, however, becoming less the exception and more the rule. Over the course of the past decade, many experiments designed to further support the idea that free radicals and other reactive molecules drive aging have instead directly challenged it. What is more, it seems that in certain amounts and situations, these high-energy molecules may not be dangerous but useful and healthy, igniting intrinsic defense mechanisms that keep our bodies in tip-top shape. These ideas not only have drastic implications for future antiaging interventions, but they also raise questions about the common wisdom of popping high doses of antioxidant vitamins. If the oxidative-damage theory is wrong, then aging is even more complicated than researchers thought—and they may ultimately need to revise their understanding of what healthy aging looks like on the molecular level.

“The field of aging has been gliding along on this set of paradigms, ideas about what aging is, that to some extent were kind of plucked out of the air,” Gems says. “We should probably be looking at other theories as well and considering, fundamentally, that we might have to look completely differently at biology.”

THE BIRTH OF A RADICAL THEORY

THE OXIDATIVE DAMAGE, or free radical, theory of aging can be traced back to Denham Harman, who found his true calling in December 1945, thanks to the *Ladies' Home Journal*. His wife, Helen, brought a copy of the magazine home and pointed out an article on the potential causes of aging, which he read. It fascinated him.

Back then, the 29-year-old chemist was working at Shell Development, the research arm of Shell Oil, and he did not have much time to ponder the issue. Yet nine years later, after graduating from medical school and completing his training, he took a job as a research associate at the University of California, Berkeley, and began contemplating the science of aging more seriously. One morning while sitting in his office, he had an epiphany—“you know just ‘out the blue,’” he recalled

When Vitamins Kill

Epidemiological studies show that people who eat lots of fruits and vegetables, which are rich in vitamins and other antioxidants, tend to live longer and are less likely to develop cancer compared with those who do not. So it seemed obvious that supplementing diet with antioxidants should lead to better health. But the results of the most rigorously designed studies do not support that assumption. Indeed, the evidence shows that some people who take certain supplements are actually more likely to develop life-threatening illnesses, such as lung cancer and heart disease.

Early Signs That Antioxidants Can Spell Trouble

A 1996 study of some 18,000 men and women found 28 percent more lung cancers and 17 percent more deaths in a group that was given beta-carotene and retinol compared with people who did not receive the antioxidants. The increased risk became clear after 18 months, particularly in heavy smokers, and was strongest among smokers who had been exposed to asbestos, a known carcinogen.

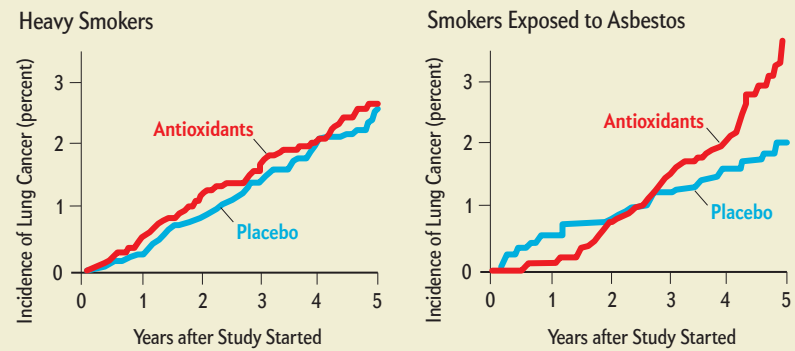

Bottom Line: Taking Some Vitamins Can Shorten Life Span

In 2007 researchers reviewed 68 of the most scientifically rigorous studies of vitamins and reported that pooling the data from the 47 trials with the least scientific bias resulted in a 5 percent increase in the rate of early death. Further analysis linked the increased risk to beta-carotene, vitamin A and vitamin E.

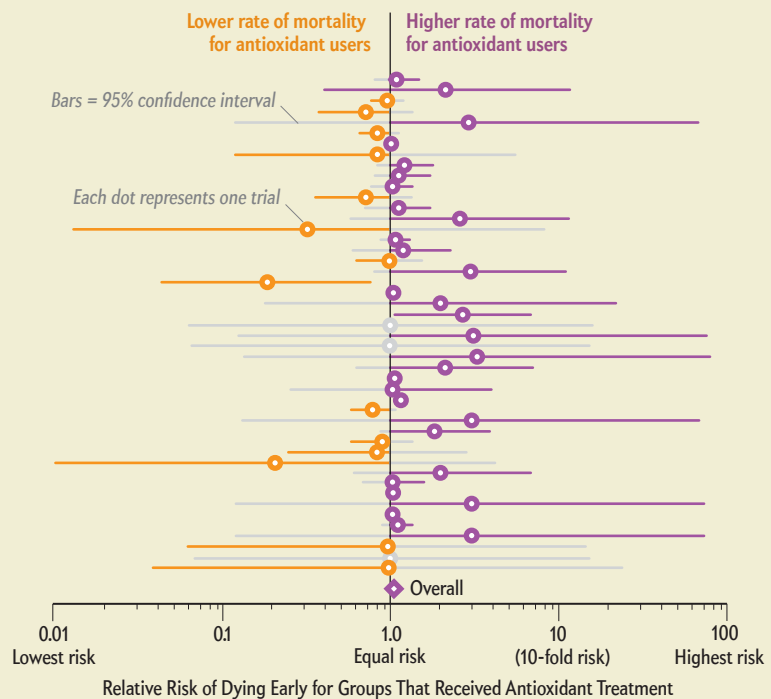

SOURCE: "RISK FACTORS FOR LUNG CANCER AND FOR INTERVENTION EFFECTS IN CARET, THE BETA-CAROTENE AND RETINOL EFFICACY TRIAL," BY GILBERT S. OMENN ET AL., IN *JOURNAL OF THE NATIONAL CANCER INSTITUTE*, VOL. 88, NO. 21, NOVEMBER 6, 1996 (top); "MORTALITY IN RANDOMIZED TRIALS OF ANTIOXIDANT SUPPLEMENTS FOR PRIMARY AND SECONDARY PREVENTION: SYSTEMATIC REVIEW AND META-ANALYSIS," BY GORAN BIELAKOVIC ET AL., IN *JAMA*, VOL. 297, NO. 8, FEBRUARY 28 (bottom)

Insight from Mutant Worms

Rather than causing aging (through oxidative chemical reactions that trigger cellular damage), some free radicals may prove beneficial. One possibility, supported by the work of Siegfried Hekimi and Wen Yang, is that a certain number of free radicals stimulate an organism's internal repair mechanisms to get to work. In their experiment on roundworms, published in 2010, the researchers genetically modified a group of worms so that they produced high levels of certain free radicals. Much to their surprise, the mutant worms lived longer than the normal worms. When the investigators fed antioxidants to the mutant worms, their longevity advantage disappeared.

Worms with More Free Radicals Lived Longer

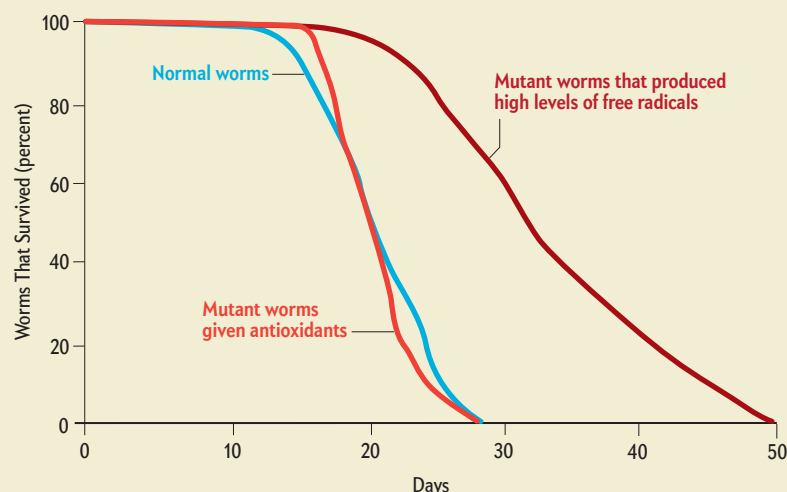

in a 2003 interview: aging must be driven by free radicals.

Although free radicals had never before been linked to aging, it made sense to Harman that they might be the culprit. For one thing, he knew that ionizing radiation from x-rays and radioactive bombs, which can be deadly, sparks the production of free radicals in the body. Studies at the time suggested that diets rich in food-based antioxidants muted radiation's ill effects, suggesting—correctly, as it turned out—that the radicals were a cause of those effects. Moreover, free radicals were normal by-products of breathing and metabolism and built up in the body over time. Because both cellular damage and free radical levels increased with age, free radicals probably caused the damage that was responsible for aging, Harman thought—and antioxidants probably slowed it.

Harman started testing his hypothesis. In one of his first experiments, he fed mice antioxidants and showed that they

lived longer. (At high concentrations, however, the antioxidants had deleterious effects.) Other scientists soon began testing it, too. In 1969 researchers at Duke University discovered the first antioxidant enzyme produced inside the body—superoxide dismutase—and speculated that it evolved to counter the deleterious effects of free radical accumulation. With these new data, most biologists began accepting the idea. “If you work in aging, it’s like the air you breathe is the free radical theory,” Gems says. “It’s ubiquitous, it’s in every textbook. Every paper seems to refer to it either indirectly or directly.”

Still, over time scientists had trouble replicating some of Harman’s experimental findings. By the 1970s “there wasn’t a robust demonstration that feeding animals antioxidants really had an effect on life span,” Richardson says. He assumed that the conflicting experiments—which had been done by other scientists—simply had not been controlled very well. Perhaps the animals could not absorb the antioxi-

dants that they had been fed, and thus the overall level of free radicals in their blood had not changed. By the 1990s, however, genetic advances allowed scientists to test the effects of antioxidants in a more precise way—by directly manipulating genomes to change the amount of antioxidant enzymes animals were capable of producing. Time and again, Richardson’s experiments with genetically modified mice showed that the levels of free radical molecules circulating in the animals’ bodies—and subsequently the amount of oxidative damage they endured—had no bearing on how long they lived.

More recently, Siegfried Hekimi, a biologist at McGill University, has bred roundworms that overproduce a specific free radical known as superoxide. “I thought they were going to help us prove the theory that oxidative stress causes aging,” says Hekimi, who had predicted that the worms would die young. Instead he reported in a 2010 paper in *PLOS Biology* that the engineered worms did not develop high levels of oxidative damage and that they lived, on average, 32 percent longer than normal worms. Indeed, treating these genetically modified worms with the antioxidant vitamin C prevented this increase in life span. Hekimi speculates that superoxide acts not as a destructive molecule but as a protective signal in the worms’ bodies, turning up the expression of genes that help to repair cellular damage.

In a follow-up experiment, Hekimi exposed normal worms, from birth, to low levels of a common weed-controlling herbicide that initiates free radical production in animals as well as plants. In the same 2010 paper he reported the counterintuitive result: the toxin-bathed worms lived 58 percent longer than untreated worms. Again, feeding the worms antioxidants quenched the toxin’s beneficial effects. Finally, in April 2012, he and his colleagues showed that knocking out, or deactivating, all five of the genes that code for superoxide dismutase enzymes in worms has virtually no effect on worm life span.

Do these discoveries mean that the free radical theory is flat-out wrong? Simon Melov, a biochemist at the Buck Institute for Research on Aging in Novato, Calif., believes that the issue is unlikely to be so simple; free radicals may be beneficial in some contexts and dangerous in others. Large amounts of oxidative dam-

age have indisputably been shown to cause cancer and organ damage, and plenty of evidence indicates that oxidative damage plays a role in the development of some chronic conditions, such as heart disease. In addition, researchers at the University of Washington have demonstrated that mice live longer when they are genetically engineered to produce high levels of an antioxidant known as catalase. Saying that something, like oxidative damage, contributes to aging in certain instances, however, is “a very different thing than saying that it drives the pathology,” Melov notes. Aging probably is not a monolithic entity with a single cause and a single cure, he argues, and it was wishful thinking to ever suppose it was one.

SHIFTING PERSPECTIVE

ASSUMING FREE RADICALS accumulate during aging but do not necessarily cause it, what effects *do* they have? So far that question has led to more speculation than definitive data.

“They’re actually part of the defense mechanism,” Hekimi asserts. Free radicals might, in some cases, be produced in response to cellular damage—as a way to signal the body’s own repair mechanisms, for example. In this scenario, free radicals are a consequence of age-related damage, not a cause of it. In large amounts, however, Hekimi says, free radicals may create damage as well.

The general idea that minor insults might help the body withstand bigger ones is not new. Indeed, that is how muscles grow stronger in response to a steady increase in the amount of strain that is placed on them. Many occasional athletes, on the other hand, have learned from painful firsthand experience that an abrupt increase in the physical demands they place on their body after a long week of sitting at an office desk is instead almost guaranteed to lead to pulled calves and hamstrings, among other significant injuries.

In 2002 researchers at the University of Colorado at Boulder briefly exposed worms to heat or to chemicals that induced the production of free radicals, showing that the environmental stressors each boosted the worms’ ability to survive larger insults later. The interventions also increased the worms’ life expectancy by 20 percent. It is unclear how

these interventions affected overall levels of oxidative damage, however, because the investigators did not assess these changes. In 2010 researchers at the University of California, San Francisco, and Pohang University of Science and Technology in South Korea reported in *Current Biology* that some free radicals turn on a gene called *HIF-1* that is itself responsible for activating a number of genes involved in cellular repair, including one that helps to repair mutated DNA.

Free radicals may also explain in part why exercise is beneficial. For years researchers assumed that exercise was good in spite of the fact that it produces free radicals, not because of it. Yet in a 2009 study published in the *Proceedings of the National Academy of Sciences USA*, Michael Ristow, a nutrition professor at the Friedrich Schiller University of Jena in Germany, and his colleagues compared the physiological profiles of exercisers who took antioxidants with exercisers who did not. Echoing Richardson’s results in mice, Ristow found that the exercisers who did not pop vitamins were healthier than those who did; among other things, the unsupplemented athletes showed fewer signs that they might develop type 2 diabetes. Research by Beth Levine, a microbiologist at the University of Texas Southwestern Medical Center, has shown that exercise also ramps up a biological process called autophagy, in which cells recycle worn-out bits of proteins and other subcellular pieces. The tool used to digest and disassemble the old molecules: free radicals. Just to complicate matters a bit, however, Levine’s research indicates that autophagy also reduces the overall level of free radicals, suggesting that the types and amounts of free radicals in different parts of the cell may play various roles, depending on the circumstances.

THE ANTIOXIDANT MYTH

IF FREE RADICALS are not always bad, then their antidotes, antioxidants, may not always be good—a worrisome possibility given that 52 percent of Americans take considerable doses of antioxidants daily, such as vitamin E and beta-carotene, in the form of multivitamin supplements. In 2007 the *Journal of the American Medical Association* published a systematic review of 68 clinical trials, which concluded that antioxidant supplements do not reduce risk of death. When the authors limited

their review to the trials that were least likely to be affected by bias—those in which assignment of participants to their research arms was clearly random and neither investigators nor participants knew who was getting what pill, for instance—they found that certain antioxidants were linked to an increased risk of death, in some cases by up to 16 percent.

Several U.S. organizations, including the American Heart Association and the American Diabetes Association, now advise that people should not take antioxidant supplements except to treat a diagnosed vitamin deficiency. “The literature is providing growing evidence that these supplements—in particular, at high doses—do not necessarily have the beneficial effects that they have been thought to,” says Demetrius Albanes, a senior investigator at the Nutritional Epidemiology Branch of the National Cancer Institute. Instead, he says, “we’ve become acutely aware of potential downsides.”

It is hard to imagine, however, that antioxidants will ever fall out of favor completely—or that most researchers who study aging will become truly comfortable with the idea of beneficial free radicals without a lot more proof. Yet slowly, it seems, the evidence is beginning to suggest that aging is far more intricate and complex than Harman imagined it to be nearly 60 years ago. Gems, for one, believes the evidence points to a new theory in which aging stems from the overactivity of certain biological processes involved in growth and reproduction. But no matter what idea (or ideas) scientists settle on, moving forward, “the constant drilling away of scientists at the facts is shifting the field into a slightly stranger, but a bit more real, place,” Gems says. “It’s an amazing breath of fresh air.” ■

MORE TO EXPLORE

Is the Oxidative Stress Theory of Ageing Dead? Viviana I. Pérez et al. in *Biochimica et Biophysica Acta*, Vol. 1970, No. 10, pages 1005-1014; October 2009.

Biology of Aging: Research Today for a Healthier Tomorrow. National Institute on Aging. National Institutes of Health, November 2011. www.nia.nih.gov/health/publication/biology-aging

Alternative Perspectives on Aging in *Caenorhabditis elegans*: Reactive Oxygen Species or Hyperfunction? David Gems and Yila de la Guardia in *Antioxidants & Redox Signaling*. Published online September 24, 2012.

SCIENTIFIC AMERICAN ONLINE

To learn more about possible molecular causes of aging, visit ScientificAmerican.com/feb2013/aging



IN BRIEF

Automated-sensor networks monitor much of our environment, but some data collection in the digital age still requires the efforts and close analyses of phalanxes of context-sensitive human beings who can help solve problems of scale.

A field called citizen science, which involves public participation in research, marshals laypeople's observations, often by way of high-tech consumer devices and machines.

Based at the Cornell Lab of Ornithology, in collabo-

ration with the National Audubon Society, eBird is one of the most mature such efforts. It and its ilk have yielded academic-caliber results in astronomy, computer science and public health, while giving skilled amateurs more opportunities to contribute.



CITIZEN SCIENCE

Data on Wings

A modest effort to enlist amateur bird-watchers in the cause of ornithology wound up producing a fire hose of data and helping rewrite the rules of science

By Hillary Rosner

Hillary Rosner has reported on science and the environment around the globe—from Borneo to Nicaragua and from Iceland to Ethiopia. She was awarded an Alicia Patterson Foundation fellowship in 2012.



IN THE 230-ACRE FOREST BEYOND STEVE KELLING'S WALL-TO-WALL OFFICE WINDOWS, 50 SPECIES OF migratory birds—warbling vireos, rose-breasted grosbeaks, cedar waxwings—have arrived overnight. On this early May afternoon their calls ring through the forest in a giant song-bird mash-up. How Kelling, or anyone here at the Cornell Lab of Ornithology in Ithaca, N.Y., can concentrate on work is a mystery.

Of course, the scene beyond the window is the work. Kelling pulls up an animated map on his laptop. It is the U.S., etched in white against a black background. A bar below the map shows the passage of time, a year in total. At first, nothing happens. Suddenly, around April, a burst of orange appears in southern California. It spreads like flames to the north and east, until the entire western third of the country is ablaze, glowing and flickering in various shades of orange and white. Then it reverses, the color vanishing from north to south, until, by November, the whole map is dark again. We have just watched the annual migration of the western tanager.

More than 300 species now have their own migration maps, generated with data collected by eBird, the 10-year-old citizen science project that Kelling oversees as director of information science at the lab. In a recent month roughly 11,000 bird-watchers uploaded more than three million sightings to eBird's database, which now contains more than 110 million records. Some 90,000 people have participated overall, and the number of records is growing by about 40 percent every year.

Birders are known for their compulsive commitment to and meticulous habits in recording their observations. Yet until recently, sharing them has taken place haphazardly and largely apart from the work of scientists. That is changing. Kelling and his colleagues are pioneers in the emerging world of citizen science. Technology—Wi-Fi, smartphones, processing capability—has revolutionized what science can do with ordinary people's data, enabling a standing army of amateurs eager to participate in real research.

Ornithologists are not the only ones benefiting. Scientists from fields as diverse as ecology, anthropology and public health have begun to take advantage of the link that technology has given them to regular people willing to work for the simple joy of

participating—or the payoff of results. (The data from eBird alone have spawned research on topics from climate science to artificial intelligence.) So far citizen scientists have discovered unknown galaxies, determined elusive protein structures, and gathered evidence needed by land managers to help protect forests and watersheds. The results from eBird—perhaps the best-known citizen science venture—show how valuable public involvement can be to a specific area of research.

Cumulatively, however, the spread of citizen science may amount to something much larger, signaling a shift in the way scientists and the public think about the enterprise of science. A new age of participatory science is taking shape at the exact moment when society may need it most—as we cope with complex problems such as climate change that require both copious data and an engaged citizenry. “Some of our biggest conservation, scientific and social challenges,” says Abe Miller-Rushing, science coordinator at Acadia National Park in Maine, “can't be addressed without it.”

BACK TO THE ROOTS

FOR STEVEN MLODINOW, an avid birder and family practice physician based in Longmont, Colo., participating in eBird makes him feel a bit like a modern-day Linnaeus, the 18th-century Swede who is considered the father of modern taxonomy. “If you go way back,” Mlodinow says, “naturalists were all untrained, and science was largely driven by people who were self-trained or minimally trained at universities. So as a doctor, I feel like I've gone back to, say, 18th-century Britain.”

Since the dawn of human expression, people have observed the world around them and recorded what they saw. Amateurs have always participated in science. Thomas Jefferson collected 50 years of weather data; Henry David Thoreau assiduously record-

Powerful Public Data

This still shot from an animated forecast of the year-round, migratory behavior of the willow flycatcher population relies on a predictive model fed with data collected by eBird volunteers. Such animated migration maps have yielded biological insights about more than 300 U.S. species. Maps for Canada, Central America and South America are in the offing. The photograph at the right shows a flycatcher.

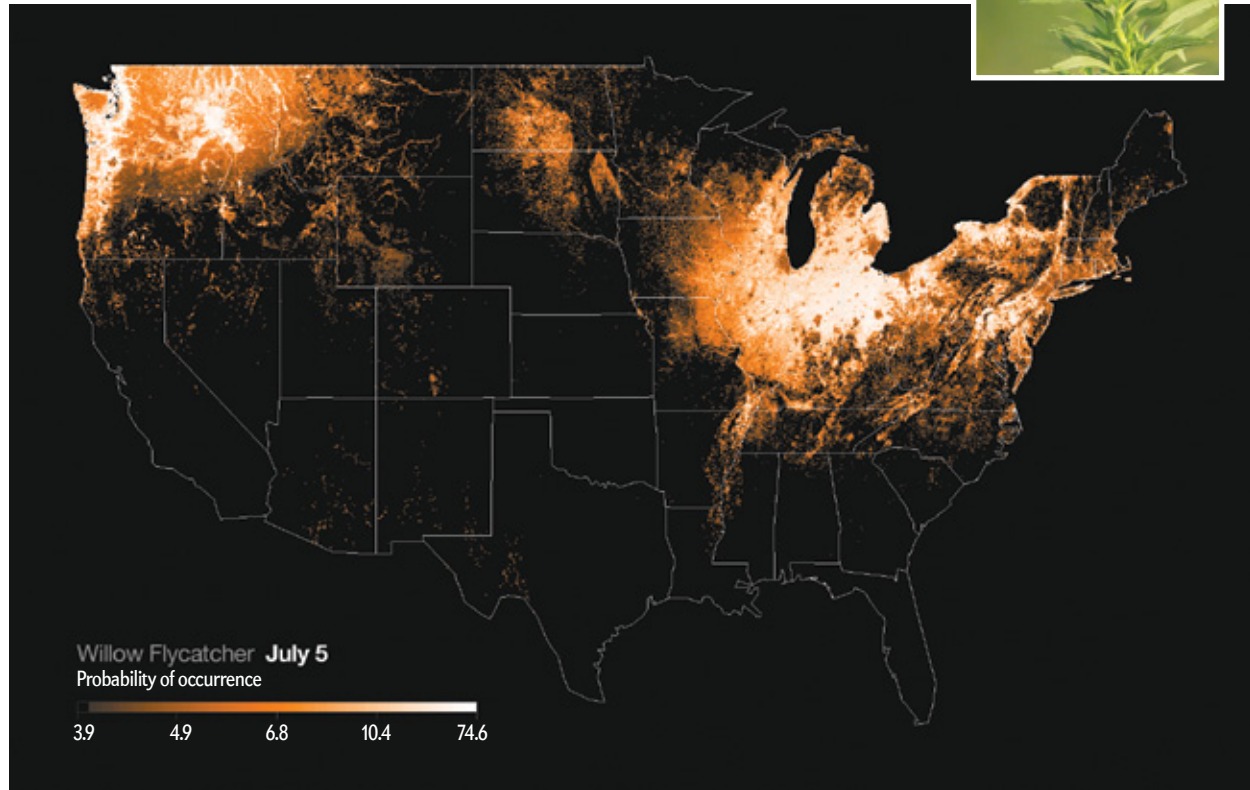
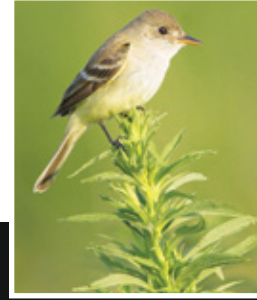

ed plants' flowering times in his local woods. Some of science's biggest breakthroughs were done by people with little to no formal training in their field—Nikola Tesla, Srinivasa Ramanujan, Isaac Newton, Charles Darwin.

Meteorology may be the clearest example. Back in the 1840s, the first secretary of the Smithsonian Institution envisioned a network of volunteer weather stations. The project swallowed a sizable portion of the institution's budget and at times had 600 participants. The telegraph helped volunteers share the nearly half a million observations gathered annually. Government agencies eventually stepped in, but a nationwide network of cooperative weather stations persists today. It hatched discoveries about weather patterns, annual snowfall, plant hardiness and the importance of topography. It also made possible the drought monitor maps we still depend on.

Input from volunteers constitutes "the majority of what we know about climate in the past," said Nolan Doesken, Colorado's state climatologist, during a recent presentation. "To put it in proper historical perspective, we need that baseline."

Ornithology is another natural fit for amateurs. Birders, after all, are already primed to collect data; they have been doing it for

centuries. Lighthouse keepers, for one, kept detailed records of birds they saw. The National Audubon Society's Christmas Bird Count has been around for more than 110 years. When eBird first launched in 2002, its leaders had a simple, one-way notion in mind: How could birders amass data so that they would be useful to scientists? Despite the fact that researchers have built large-scale automated-sensor networks all over the world to monitor virtually every aspect of our environment (atmospheric carbon, stream flows, rainfall, nitrogen pollution), some data collection still requires humans. "There are no autonomous sensors that can identify birds—or any organism, for that matter," Kelling says. "So what you have to do is replace those autonomous sensors with a type of sensor that can make the right kind of decisions and observations." In other words, an actual person—in the eBird case, the kind who is obsessed with finding, watching, counting and bragging about birds.

The project quickly hit a wall, however. Birders were entering around 50,000 records each month, too little to be useful, and that number would not budge. "After two and a half years," Kelling recalls, "we recognized that we were failing. We needed somebody from the birding community to champion us." The

lab hired two experienced birders to oversee the project (and later added a third).

The key, the team quickly realized, was ensuring that birders got something out of the arrangement, too. The eBird scientists wanted data that could help with conservation. Yet that was not enough to motivate the bird-watchers, who had to spend extra time learning the database, changing their note-taking habits and uploading records. The new project leaders also pondered what tools bird-watchers would love.

Bird-watching is ultimately a form of list keeping. So, to attract the community, says Chris Wood, one of the project leaders, eBird would have to offer new and better things to do with those lists: organizing them, sharing them, using them as the basis for (mostly) friendly competition. Today eBird is almost like Facebook for birders, a social network they can use to track and broadcast their birding lives. The eBird database, as well as an associated smartphone app, lets birders organize everything from their life lists—all the species they have ever seen—to the number of times they have seen a particular species, to lists of what they have seen at favorite spots. Just as important, they can see everyone else's lists—then try their damndest to outdo them. When Mlodinow saw two least flycatchers at an eastern Colorado grassland, he could quickly see that his was the earliest sighting of the bird that spring. “Yes, we got the record!” he exclaimed.

BEYOND BIRDS

How to Get Involved

If you would rather skip the Ph.D. and dive right into assisting with academic-caliber scientific research, here are a few resources to help find a citizen science project suited to your skills and interests.

ZOONIVERSE: Join hundreds of thousands of people who are participating in science projects on topics such as discerning signs of exoplanets in light-curve changes and describing digitized 19th-century piano scores. www.zooniverse.org

SCIENTIFIC AMERICAN'S CITIZEN SCIENCE

PROJECTS PAGE: More than 100 mostly free projects are indexed and described on this mini site, which is updated weekly. Projects can be sorted by cost to participate and type of work: observation, questionnaire, fieldwork or data processing. www.scientificamerican.com/citizen-science

AMERICAN GUT PROJECT: It's not free or pretty, but you can take part at various price points, including an option that provides a stool, skin or oral sample collection kit. Simply put, participants help scientists characterize the microbial diversity of the American public and ascertain the impact of diet. www.indiegogo.com/american-gut

CITIZEN SCIENCE CENTRAL: It's hardly all about birds at the Cornell Lab of Ornithology. This portfolio of more than 140 projects can be browsed by categories such as water quality, weather and astronomy. www.birds.cornell.edu/citescitoolkit

“It's hard to overestimate what a powerful motivating effect those games can have,” Wood says later.

Sitting in a conference room at the Cornell Lab—more wall-to-wall windows on the chattering forest—Wood pulls up the records for a county in southwestern Kansas. “You can see who has submitted the most checklists and seen the most species,” he says. Kelling, who has been sitting quietly at the far end of the table, suddenly pipes up:

“I'm the highest list in Tompkins County,” he boasts. “No, he's not!” Wood tells me, grinning. “He thinks he is.”

Still, eBird is not all fun and bird games. Citizen science comes with serious challenges, perhaps the biggest of which is how to ensure that data are trustworthy. One way eBird's leaders help to maintain data quality is by relying on birders to serve as regional experts. In Colorado, Mlodinow and two other birders—science teacher Bill Schmoker and wildlife monitor Christian Nunes—spend hours every week uploading their observations and vetting others' records. They look at any data the system flags as questionable, up to 8 percent of the three million records entered each month. Their work helps to keep the records as accurate as possible. (It also trains algorithms to weight different contributors' records based on their level of expertise.)

These efforts seem to be bearing fruit. The eBird data are holding up and are beginning to have an impact on public policy. By overlaying eBird distribution data on U.S. public lands maps, researchers have determined which threatened or endangered birds occur on which federal agency's land at which time of year—knowledge the agencies use to determine budget priorities.

A new project using eBird data, known as BirdCast, issues migration forecasts—imagine a weather report that predicts flocks of Baltimore orioles instead of thunderstorms. “The cool thing about Doppler radar,” Kelling says, “is it doesn't care what it bounces off of—bugs, smoke, birds.” He pulls up a familiar-looking radar image of moving clouds. But he is watching something else: not the blue of the storm cells but smaller green areas—flocks of birds flying through the night. By combining eBird data with radar images, weather information and computer models, BirdCast will soon be able to generate weekly migration predictions for any area of the country. (Currently the lab issues weekly forecasts during spring and fall migration periods, as well as special reports for unusual events such as superstorm Sandy.) These reports, Kelling says, could prompt cities to turn off their downtown lights or wind farms to shut off their turbines on nights when thousands of birds are passing overhead.

Citizen science projects of all stripes are generating research with practical applications. LiMPETS, a long-term monitoring program on the California coast, relies on students and teachers to gather data that will help direct cleanups after an oil spill or other coastal contamination. The Wisconsin Department of Natural Resources draws on citizens to keep tabs on local air, water and wildlife. Across the globe in the African Sahel, the Meningitis Weather Project, run by the University Corporation for Atmospheric Research, used villagers' observations of local weather patterns to predict the onset of the rainy season, when meningitis risk drops dramatically and vaccinations become unnecessary; the project helps to extend the vaccine supply.

Beyond aiding public policy, citizen science solves a problem of scale. Scientists cannot be everywhere at once, a fact that has

left us with what Arfon Smith, director of citizen science at Chicago's Adler Planetarium, calls "fogs of ignorance"—points on a map where we have almost no historical data on phenomena such as weather events or biodiversity. Expanding the number of people observing the world, whether flowers or stars or toxins, improves our capacity to understand it.

A NEW FIELD OF SCIENCE

ON A SWELTERING AUGUST weekend in Portland, nearly 300 people packed a room at the Oregon Convention Center for the Conference on Public Participation in Scientific Research. Over two days participants showcased their projects, introduced databases and other practical tools, chronicled the historical contributions of amateurs, and made the case that public participation in science could be an engine for change. The conference concluded with a massive brainstorming session about what exactly citizen science would look like as a formalized field—with a professional organization, annual meetings and a journal.

Miller-Rushing from Acadia and two researchers from the Cornell Lab, Rick Bonney and Jennifer Shirk, hatched the conference idea over dinner one night. In 2006 the lab received National Science Foundation funds to develop best practices for citizen science. Now the lab is the field's de facto headquarters. Bonney is credited with coining the term "citizen science" in the 1990s; Shirk, curious why scientists would undertake these projects given the professional risk and potential for logistical headaches, is studying the field for her Ph.D.

One reason they are pushing to create an official discipline is to trade ideas across far-flung research areas: ecology, astronomy, computer science, epidemiology. The scientists of citizen science need a forum, Shirk says, "to get together and say, 'Here's what I'm doing, here's what we're struggling with.'" Researchers could draw from one another's success or failure with such tasks as recruiting volunteers or coping with a crushing amount of data.

For public participation in scientific research to become its own field, it will have to solve some challenges. For one, how do you knit together the vastly different goals and project types? Researchers have tried to catalogue projects, but at a fundamental level citizen science projects fall into two categories: those where the public directly serves the scientists and those where the scientists directly serve the public. (The two groups are not mutually exclusive; having better data on animal migrations or droughts or molecular structures arguably also serves the public.)

Galaxy Zoo, home to some of the world's best astronomical information, began with a group of postdoctoral researchers drowning in downloads from the Sloan Digital Sky Survey. Galaxy Zoo now includes images from the Hubble Space Telescope and has spawned a family of online citizen science projects called Zooniverse, in which volunteers help to make sense of data. Zooniverse's nearly 720,000 participants transcribe weather observations from World War I warships, identify species in photographs from the seafloor and categorize whale calls. The scientists benefit from all these projects. At the other end of the spectrum, researchers participating in University College London's new Extreme Citizen Science (ExCiteS) group are helping marginalized communities empower themselves through science. In a recent project, residents of one blighted London neighborhood collected more than 1,100 noise samples, using decibel monitors, to show that a nearby scrap yard was deafen-

ing. The university's geographic information system (GIS) experts turned the data into a neighborhood noise map, which was instrumental in convincing local officials to regulate the scrap yard's volume.

Such community-based projects turn science into a social endeavor. At the Portland conference, one participant spoke of "incorporating multiple kinds of knowledge"—information from indigenous communities, local hunters, or other people with traditional learning or a deep sense of place. That concept may be hard for some scientists to stomach.

Muki Haklay, co-director of ExCiteS, believes it is time to evolve. Researchers need to think of citizen science as simply "a different way of producing scientific knowledge," he says. When the London neighborhood measured noise levels, for instance, Haklay says that he did not present the results as the final scientific conclusion. He merely passed them on to local authorities as evidence that they needed to come take a look. "You make a claim for what it's worth and how it's relevant to people's life," he notes.

One of citizen science's most important contributions may ultimately be to spread scientific literacy by giving laypeople direct contact with the process of science. "I really like the idea," Smith says, "of increasing an understanding of the scientific method, involving people in the nitty-gritty of science. If you can see more of the actual process and get exposure to more parts of the scientific work flow, then that's going to be good."

Whether it is learning the difference between elliptical and spiral galaxies, discovering how a protein's structure determines its function, helping to count wildlife or deciphering the chemical composition of a local stream, the act of directly engaging with science can be transformative. At the Portland conference, Wallace J. Nichols, a marine biologist known for his work protecting sea turtles, produced a tangible ripple of excitement in the room when he compared citizen scientists to sea star arms that break off, float away and form new organisms. "You never know what they're going to do," Nichols said.

One sunny afternoon last spring, out for a tour of a Colorado birding hotspot with eBird's Mlodinow, Schmoker and Nunes, I asked why they devote so much time to the project. I wondered if they were just do-gooders or if they felt some kind of responsibility to eBird now that it had given them handy new tools. "For a lot of serious birders," Mlodinow replied, "the scientific part of it is of note. We're frequently trying to dissect subspecies, to figure out what the ranges of subspecies are—which isn't really known, especially during migration. I think, in the long run, this will change our understanding of where subspecies are distributed." Spoken like a true scientist. ■

MORE TO EXPLORE

Citizen Science: A Developing Tool for Expanding Science Knowledge and Scientific Literacy. Rick Bonney et al. in *Bioscience*, Vol. 59, No. 11, pages 977–984; December 2009.

Reinventing Discovery: The New Era of Networked Science. Michael Nielsen. Princeton University Press, 2011.

Participatory Design of DataONE—Enabling Cyberinfrastructure for the Biological and Environmental Sciences. William K. Michener et al. in *Ecological Informatics*, Vol. 11, pages 5–15; September 2012. www.sciencedirect.com/science/article/pii/S1574954111000768

SCIENTIFIC AMERICAN ONLINE

See maps of bird migration forecasts at

ScientificAmerican.com/feb2013/citizen-science

RHONE RIVER, NOV. 29 – DEC. 6, 2013



For information on more trips like this, please log onto www.ScientificAmerican.com/Travel

In November, the tourists are gone from Provence. The harvest's been gathered. The south of France exhales, resuming her essential rhythms, manifesting her ancient uniqueness, effortlessly. It's the perfect time to relax, recharge, and revel in the latest with Scientific American Bright Horizons 18 on a Rhone River cruise from November 29 to December 6, 2013. We'll explore developments in cosmology, cancer, and wine science, and plumb Roman engineering.

Experience river cruising's panoramic charms on Bright Horizon 18's voyage on AmaWaterway's AmaDagio, sailing from Lyon to Arles, France. The light, colors, and flavors of France await.

Make your reservation at <http://www.insightcruises.com/SciAm-18>, call us at 650-787-5665 or email us at Concierge@InsightCruises.com.

The cruise fares start at \$2,799 for a Category E. French Balcony cabins start at \$3,378. A Junior Suite is available for \$4,498. Cruise fares include six half-day excursions. For those attending our educational Program, there is a \$1,395 fee. Additional per-person fees include: government taxes and fees (\$147) and gratuities are €15 per day. The Program, Cruise pricing, and options are subject to change. For more info please call 650-787-5665 or email us at concierge@insightcruises.com.



Quantum Physics

Speaker: Frank Linde, Ph.D.

The Wild World of Subatomic Particles

Explore the realm of electrons, protons, quarks, and Higgs bosons — a world where the normal rules don't apply. Dr. Linde will lead a tour of the smallest constituents of matter, illuminating the theories of quantum mechanics and relativity that govern the subatomic universe. You'll also learn about the mysteries of dark matter, missing antimatter, and the origin of mass.

The Story of the Higgs

A tiny particle called the Higgs boson was predicted 50 years ago to explain the quandary of why particles have mass. After decades of searching, physicists finally tracked down the Higgs in 2012, inside the world's largest particle accelerator. Learn why this one particle is so important, and how its discovery will shape the future of physics.



The Mystery of Dark Matter

Dark matter is thought to make up about a quarter of the universe, yet scientists don't know what it is. Learn the history of this mysterious stuff, as well as the best guesses for what it might be made of. Dr. Linde will explain how researchers study something that can't be seen, and the ongoing searches aiming to detect dark matter for the first time.

Particle Physics and You

Subatomic particle experiments deep underground and inside giant accelerators can seem far removed from everyday life. But the knowledge gained about the universe's smallest building blocks has real-world consequences. Dr. Linde will stir your curiosity about particle physics and answer the common question: What use is it?

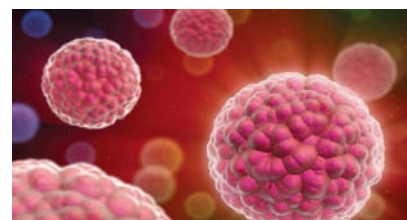

Targeting Cancer

Speaker: David Sadava, Ph.D.

Know the Enemy:

A Biography of the Target

Set the stage for understanding the attack on cancer by looking at its cellular biography. In most cases, cancer starts off as perfectly normal cells. And then something happens. Find out what those "somethings" may be, and how they transform the cell.

The War on Cancer: Then and Nowadays

In 1972, the U.S. declared war on cancer. Learn the scientific background that led to this bold declaration, and why victory has been elusive.

We see progress in extending the lives of cancer patients, and even cures. But the result is not victory but a long war of attrition. Find out why.

Targeting the Cancer Genome

Knowing the cancer genome in detail leads to precise targeting of potential cancer triggers in the cell. Two spectacular recent successes in targeting certain types of leukemia and breast cancer led to a proliferation of very expensive drugs similarly targeted to specific cancers. Are these drugs worth it? Explore the scientific accomplishments and ethical issues involved in medical progress.

Natural Medicine and the War on Cancer

Faced with a dreadful diagnosis, many cancer patients supplement or substitute their doctor's recommendations by "going alternative." Turns out that some common cancer-fighting drugs originated in traditional medicines. Learn about the process of transforming a traditional treatment to a mainstream therapy. How are alternative medicines evaluated? Are they effective? Join Dr. Sadava and make some surprising discoveries.



Archaeology

Speaker: Lynne Lancaster, Ph.D.

Introduction to Culture and Technology in Gaul

Gaul was influenced by the Iberians, Celts, Greeks, and Romans. Each culture brought skills and technologies such as town planning, architecture and construction, mining of salt and metals, and the adoption of coinage. Get an overview of the technology, culture, and politics of the Greek and Roman colonization of France.

Fire-Based Technologies in Gaul: Terracotta Production and Metal-Working

Terra cotta and metal artisans had to master techniques of balancing chemical interaction to achieve the desired results. Find out how the Romans adopted Greek methods to mass produce pottery. In contrast to this imported knowledge, learn about Celtic metal-working skills, which the Romans assimilated and put to military use.

Building an Amphitheater

Along with bath buildings, the construction of an amphitheater was one of the greatest investments a community could take on. Dig into the engineering and construction process: site preparation for enormous loads, quarrying and transporting great numbers of stone blocks, erecting the structure and distributing loads. Enrich your appreciation of ancient architecture in the Roman world and beyond.

Aqueducts, Baths and Water Mills

The Romans exploited water technology much earlier and on a greater scale than has been realized. This was all possible due to

the mastery of aqueducts. We will explore the principles behind the laying out and functioning of Roman aqueducts, including the use of inverted siphons, tunnel cutting, and arch construction.



Cosmology

Speaker: Mark Whittle, Ph.D.

The Birth of Our Universe: Evidence for the Big Bang

Is the current evidence for the Big Bang strong enough to consider it a fact? Survey the contents of the Universe and scrutinize the six key pieces of evidence for its birth in a "Hot Big Bang."

Billion Years of History: the Birth and Maturation of Galaxies

Study the natural history and structure of galaxies directly, from infancy to maturity. Orient yourself to our own Milky Way, and the types of galaxies that form a web of galaxies filling the Universe. Contemplate dark matter and black holes, and get the latest thought in cosmology.

The Universe's First Million Years: Primordial Light and Sound

Take a trip back in time to explore the incandescent fireball of the infant Universe, just ½ million years after the Big Bang. Learn the astounding qualities of its light and how cosmologists use the primordial sound of this period to measure a number of the Universe's properties. Listen, think, and wonder at the cosmological Dark Age before the first stars.

Cosmic Inflation: Making Universe(s) from Nothing!

How was our expanding Universe created? We'll look to cosmic inflation theory for answers and food for thought. Using the astonishing fact that the total mass/energy of the Universe is zero, and its implications, we can begin to understand how cosmic inflation both creates

and launches our expanding Universe — out of nothing! Examine cosmic puzzles, possibilities, and intriguing speculation.



Oenology

Speaker: James Kennedy, Ph.D.

Climate Change and Impact on the Wine World

Wine's chemical composition varies widely across different areas of the world. Much of a wine's uniqueness stems from the impact of place on wine composition. Discover how the climates in the wine regions of the world are changing, and what this means for wine as we know it. In a lab session, we'll taste wine from warm regions.

The Rhone and Its Wines

The Rhone River region produces some of the finest wines in the world. As the Rhone River flows south to the Mediterranean, the grapes and the wines produced from them change considerably. Combining a lecture with a wine tasting, Dr. Kennedy will discuss this amazing wine-growing region and the wines it produces.

Wine and Health

From the French Paradox to resveratrol and beyond, Dr. Kennedy investigates the composition of wine and the role that wine plays in human health. Is wine the wonder beverage as often portrayed in popular media, or is the fascination just a means to feel good about alcohol consumption?

Advances in Grape and Wine Production

Wine labels often evoke the tradition, romance, and history of winemaking. The flowery language and imagery obscures the technological progress made over the past century in viticultural and winemaking practices. Discover how some of the finest wines in the world are produced using sophisticated, state-of-the-art technology and science.

SCIENTIFIC AMERICAN

Travel

HIGHLIGHTS RHONE RIVER
NOV. 29 – DEC. 6, 2013



INSIDER'S TOUR OF CERN

Pre-cruise: November 28, 2013—From the tiniest constituents of matter to the immensity of the cosmos, discover the wonders of science and technology at CERN. Join Bright Horizons for

a private pre-cruise, custom, full-day tour of this iconic facility. (If the LHC is still undergoing its scheduled maintenance it is anticipated we will go into the LHC Cavern.)

Whether you lean toward concept or application there's much to pique your curiosity. Discover the excitement of fundamental research and get a behind-the-scenes, insider's look at the world's largest particle physics laboratory.

We'll have an orientation, visit an experiment, get a sense of the mechanics of the Large Hadron Collider (LHC). If at all possible, we'll go down inside the LHC tunnel (picture left), then make a refueling stop for lunch, and have time to peruse the grounds and exhibits on the history of CERN and the nature of its work. And if you're so inclined, you can visit the CERN gift shop.

The price is \$899 per person (based on double occupancy). This trip is limited to 50 people. NOTE: CERN charges no entrance fee to visitors.

For more info please call 650-787-5665 or log on to ScientificAmerican.com/Travel



WORM living on methane ice, Gulf of Mexico

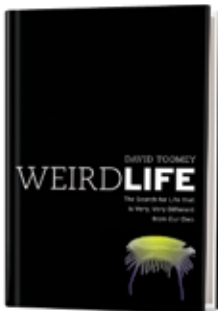

Weird Life: The Search for Life That Is Very, Very Different from Our Own

by David Toomey. W. W. Norton, 2013 (\$25.95)

Life, researchers have learned, can sometimes thrive in places that would kill most organisms. The strangest life bathes in acid (multihued bacteria growing in Yellowstone National Park), floats through clouds (microbial algae, fungi and bacteria), and flourishes around boiling hydrothermal vents (giant clams and tube worms sustained by heat-loving bacteria). As English professor Toomey tracks the work of scientists who hunt for such extreme examples, he explores the very definition of life. He also envisions the truly weird life-forms that might exist elsewhere in the universe—such as bacteria that ride on icy comets or even “living” networks of charged dust grains that circle black holes and communicate with one another electromagnetically.

—Marissa Fessenden



Animal Wise: The Thoughts and Emotions of Our Fellow Creatures

by Virginia Morell. Crown, 2013 (\$26)

For much of the 20th century the study of animal minds was off-limits to researchers. Endowing nonhumans with psychological or emotional traits was considered unscientific, an attitude that dates back nearly 400 years ago to René Descartes, who believed animals were lesser beings with no capacity for reason. Morell, a correspondent for *Science*, argues that biologists are finally breaking this taboo. Each chapter takes readers on an adventure alongside researchers as they probe the minds of such disparate creatures as ants, trout, dolphins, elephants and chimpanzees.



Blackett's War: The Men Who Defeated the Nazi U-Boats and Brought Science to the Art of Warfare

by Stephen Budiansky. Knopf, 2013 (\$27.95)

During World War II a relatively unheralded group of civilian researchers, led by British ex-naval officer and future Nobel Prize-winning physicist Patrick Blackett, collaborated on finding ways to subdue the Nazi U-boat fleet. Journalist Budiansky details how Blackett and his colleagues' unconventional application of science and mathematics changed military strategy—for example, by applying probability theory to help determine the location of submarines.

—Marissa Fessenden



The Measure of Manhattan: The Tumultuous Career and Surprising Legacy of John Randel, Jr. Cartographer, Surveyor, Inventor

by Marguerite Holloway. W. W. Norton, 2013 (\$26.95)

Holloway, a former editor at *SA*, uses the little-known story of the man behind Manhattan's street grid to talk about larger issues surrounding urban planning and the way humans “tame” the natural world. The grid's geometry reflected a belief at the time that math could elevate society.

SCIENTIFIC AMERICAN ONLINE

For more recommendations, go to ScientificAmerican.com/feb2013/recommended

COURTESY OF NOAA

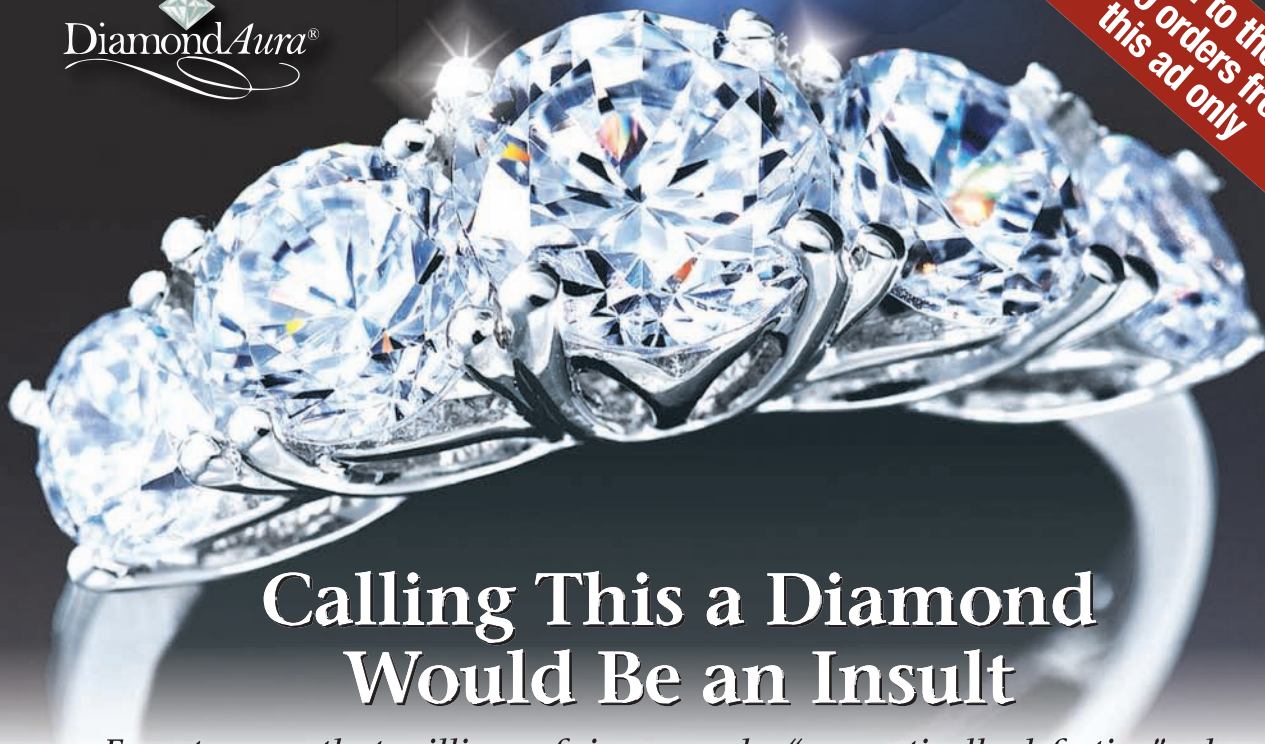

Limited to the first 2500 orders from this ad only

Calling This a Diamond Would Be an Insult

Experts warn that millions of rings may be "romantically defective" when compared to the stunning DiamondAura® 5-Stone Ring for **ONLY \$99!**

She loves natural diamonds. She loves you even more. But when even 1-carat stones can sell for as much as \$9,000, it's time to reconsider your relationship... with diamonds. Compared to the Stauer DiamondAura® 5-Stone Ring with nearly 2 1/2 carats, a skimpy diamond is "romantically defective." Have you over-paid only to be underwhelmed? Send it back. You can do better. You can do bigger. And you can absolutely take her breath away for **under \$100.**

When "cute" is a four-letter word. If you want to make a romantic impression, go big. Cute doesn't cut it. Your love deserves to be wowed. If you're a billionaire with money to burn, turn the page. Everyone else? What you read next just might change your life. There's only one way to find out...

Science not snobbery. Thanks to the advanced science behind our exclusive DiamondAura, you can experience superior clarity and larger carat weights without the outrageous cost of natural diamonds. DiamondAura is crafted using an incredibly complex process that involves heating rare minerals to temperatures of nearly 5000°F. After expert cutting and polishing, every lab-created DiamondAura retains the



EXCLUSIVE BONUS OFFER!
Order today to get these **FREE 1-Carat DiamondAura® sterling-silver studs PLUS \$300 in Stauer Gift Coupons!****

classic jeweler's specifications, including color, clarity, cut and carat weight. DiamondAura doesn't emulate the world's most perfect diamonds... it surpasses them. The color dispersion is **actually superior to mined diamonds.** You get more sparkle, fire and flawless beauty for a fraction of the price.

Scintillating in sterling silver. Our quest for perfection doesn't end in the lab. Passionate designers bring inspiration from history books and Fifth Avenue showrooms to every inch of the **5-Stone Ring.** The ring features a classic quintet of round-cut, lab-created DiamondAura, 2 1/3 carats prong-set in the finest .925 sterling silver. A spectacular alternative for those occasions when a lonely solitaire will simply not suffice.

Romantic satisfaction guaranteed. If for any reason she doesn't completely adore the **5-Stone DiamondAura Ring,**

return it within 30 days for a full refund of your purchase price. We're so confident you'll fall for DiamondAura, that we'll include a stunning \$99 pair of 1-carat DiamondAura studs in sterling silver... absolutely FREE. **Plus, when you call today, you'll also get \$300 in Stauer Gift Coupons (\$25 to use every month for 12 months with no minimum purchase required)! You played by the old rules and the big jewelry stores emptied your pockets. Our job is to fill them back up!

JEWELRY SPECS:

- 2 1/3 ctw brilliant white DiamondAura®
- .925 sterling-silver setting

DiamondAura® 5-Stone Ring
(2 1/3 ctw) **\$99**

Include \$99 Stud Earrings (1 ctw) ~~\$198~~

NOW BOTH ONLY — \$99 + S&P

Specify ring whole size 5-10 when ordering.

Call now to take advantage of this extremely limited offer.

1-888-870-7382

Promotional Code FSR231-03
Please mention this code when you call.

Stauer®

14101 Southcross Drive W.,
Dept. FSR231-03
Burnsville, Minnesota 55337
www.stauer.com



Rating of A+

Smart Luxuries—Surprising Prices

Michael Shermer is publisher of *Skeptic* magazine (www.skeptic.com). His book *The Believing Brain* is now out in paperback. Follow him on Twitter @michaelshermer



The Left's War on Science

How politics distorts science on both ends of the spectrum

Believe it or not—and I suspect most readers will not—there's a liberal war on science. Say what?

We are well aware of the Republican war on science from the eponymous 2006 book (Basic Books) by Chris Mooney, and I have castigated conservatives myself in my 2006 book *Why Darwin Matters* (Henry Holt) for their erroneous belief that the theory of evolution leads to a breakdown of morality. A 2012 Gallup poll found that “58 percent of Republicans believe that God created humans in their present form within the last 10,000 years,” compared with 41 percent of Democrats. A 2011 survey by the Public Religion Research Institute found that 81 percent of Democrats but only 49 percent of Republicans believe that Earth is getting warmer. Many conservatives seem to grant early-stage embryos a moral standing that is higher than that of adults suffering from debilitating diseases potentially curable through stem cells. And most recently, Missouri Republican senatorial candidate Todd Akin gaffed on the ability of women's bodies to avoid pregnancy in the event of a “legitimate rape.” It gets worse.

The left's war on science begins with the stats cited above: 41

percent of Democrats are young Earth creationists, and 19 percent doubt that Earth is getting warmer. These numbers do not exactly bolster the common belief that liberals are the people of the science book. In addition, consider “cognitive creationists”—whom I define as those who accept the theory of evolution for the human body but not the brain. As Harvard University psychologist Steven Pinker documents in his 2002 book *The Blank Slate* (Viking), belief in the mind as a tabula rasa shaped almost entirely by culture has been mostly the mantra of liberal intellectuals, who in the 1980s and 1990s led an all-out assault against evolutionary psychology via such Orwellian-named far-left groups as Science for the People, for proffering the now uncontroversial idea that human thought and behavior are at least partially the result of our evolutionary past.

There is more, and recent, anti-science fare from far-left progressives, documented in the 2012 book *Science Left Behind* (PublicAffairs) by science journalists Alex B. Berezhov and Hank Campbell, who note that “if it is true that conservatives have declared a war on science, then progressives have declared Armageddon.” On energy issues, for example, the authors contend that progressive liberals tend to be antinuclear because of the waste-disposal problem, anti-fossil fuels because of global warming, antihydroelectric because dams disrupt river ecosystems, and anti-wind power because of avian fatalities. The underlying current is “everything natural is good” and “everything unnatural is bad.”

Whereas conservatives obsess over the purity and sanctity of sex, the left's sacred values seem fixated on the environment, leading to an almost religious fervor over the purity and sanctity of air, water and especially food. Try having a conversation with a liberal progressive about GMOs—genetically modified organisms—in which the words “Monsanto” and “profit” are not dropped like syllogistic bombs. Comedian Bill Maher, for example, on his HBO *Real Time* show on October 19, 2012, asked Stonyfield Farm CEO Gary Hirshberg if he would rate Monsanto as a 10 (“evil”) or an 11 (“f—ing evil”)? The fact is that we've been genetically modifying organisms for 10,000 years through breeding and selection. It's the only way to feed billions of people.

Surveys show that moderate liberals and conservatives embrace science roughly equally (varying across domains), which is why scientists like E. O. Wilson and organizations like the National Center for Science Education are reaching out to moderates in both parties to rein in the extremists on evolution and climate change. *Pace* Barry Goldwater, extremism in the defense of liberty may not be a vice, but it is in defense of science, where facts matter more than faith—whether it comes in a religious or secular form—and where moderation in the pursuit of truth is a virtue. ■

SCIENTIFIC AMERICAN ONLINE

Comment on this article at ScientificAmerican.com/feb2013

Chicago Doctor Invents Affordable Hearing Aid Outperforms Many Higher Priced Hearing Aids

Reported by J. Page

CHICAGO: A local board-certified Ear, Nose, Throat (ENT) physician, Dr. S. Cherukuri, has just shaken up the hearing aid industry with the invention of a medical-grade, affordable hearing aid. **This revolutionary hearing aid is designed to help millions of people with hearing loss who cannot afford—or do not wish to pay—the much higher cost of traditional hearing aids.**

“Perhaps the best quality-to-price ratio in the hearing aid industry” – Dr. Babu, M.D. Board Certified ENT Physician

Dr. Cherukuri knew that untreated hearing loss could lead to depression, social isolation, anxiety, and symptoms consistent with Alzheimer’s dementia. **He could not understand why the cost for hearing aids was so high when the prices on so many consumer electronics like TVs, DVD players, cell phones and digital cameras had fallen.**

Since Medicare and most private insurance do not cover the costs of hearing aids, which traditionally run between \$2000-\$6000 for a pair, many of the doctor’s patients could not afford the expense. Dr. Cherukuri’s goal was to find a reasonable solution that would help with the most common types of hearing loss at an affordable price, not unlike the **“one-size-fits-most” reading glasses** available at drug stores.

- **Designed By A Board Certified Ear, Nose and Throat (ENT) Doctor**
- **Doctor-Recommended, Audiologist-Tested**
- **★★★★★ Top rated hearing aid online—thousands of satisfied customers**
- **FDA-Registered**
- **Save Up To 90%**
- **Free Shipping Available**
- **Batteries Included! Comes Ready To Use**
- **100% Money Back Guarantee**



He evaluated numerous hearing devices and sound amplifiers, including those seen on television. Without fail, almost all of these were found to amplify bass/low frequencies (below 1000 Hz) and not useful in amplifying the frequencies related to the human voice.

Inspiration from a surprising source

The doctor’s inspiration to defeat the powers-that-be that kept inexpensive hearing aids out of the hands of the public actually came from a new cell phone he had just purchased. **“I felt that if someone could devise an affordable device like an iPhone® for about \$200 that could do all sorts of things, I could create a hearing aid at a similar price.”**

Affordable Hearing Aid With Superb Performance

The high cost of hearing aids is a result of layers of middlemen and expensive unnecessary features. Dr. Cherukuri concluded that it would be possible to develop a medical grade hearing aid without sacrificing the quality of components. The result is the MDHearingAid PRO®, starting well under \$200. **It has been declared to be the best low-cost hearing aid that amplifies the range of sounds associated with the human voice without overly amplifying background noise.**

Tested By Leading Doctors and Audiologists

The MDHearingAid PRO® has been rigorously tested by leading ENT physicians and audiologists who have unanimously agreed that the **sound quality and output in many cases exceeds more expensive hearing aids.**

DOCTORS AND PATIENTS AGREE: “BEST QUALITY SOUND” “LOWEST AFFORDABLE PRICE”

*“I have been wearing hearing aids for over 25 years and these are the best behind-the-ear aids I have tried. **Their sound quality rivals that of my \$3,000 custom pair of Phonak Xtra digital ITE**” —Gerald Levy*

*“I have a \$2,000 Resound Live hearing aid in my left ear and the MDHearingAid PRO® in the right ear. **I am not able to notice a significant difference in sound quality between the two hearing aids.**” —Dr. May, ENT physician*

*“We ordered two hearing aids for my mother on Sunday, and the following Wednesday they were in our mailbox! Unbelievable! Now for the best part—they work so great, my mother says she hasn’t heard so good for many years, even with her \$2,000 digital! **It was so great to see the joy on her face.** She is 90 years young again.” —Al Peterson*

**For the Lowest Price Call Today
1-800-873-0680**

Phone Lines Open 24 Hours EVERY DAY

www.MDHearingAid.com/DJ09

**Use Offer Code DJ09 to get
FREE Batteries for a Full Year!**

FREE Shipping Available

MDHearingAidPRO® >>>
THE DOCTOR’S CHOICE FOR AFFORDABLE HEARING AIDS



**45 DAY
RISK FREE
TRIAL**



Proudly assembled in the USA



Steve Mirsky has been writing the Anti Gravity column since a typical tectonic plate was about 33 inches from its current location. He also hosts the *Scientific American* podcast Science Talk.



Still Crazy after All These Fears

The world will end,
but not for a long, long time

Congratulations, you survived the Mayan apocalypse. I knew you could do it.

I had complete confidence that I would live past the alleged planetary expiration date of December 21, 2012, provided I didn't get hit by a bus or slip in the bathtub. But those modes of demise are, of course, far less tantalizing than some end-of-the-world fantasy dreamed up by amateur archaeologists and sucked down by people who perhaps never worry that they have undiagnosed hypertension or that the highway bridge they cross daily hasn't been properly maintained.

So many people heard so much dumb stuff about the world ending that official government agencies went out of their way to calm down small segments of their populations.

According to the *New York Times*, Russia's minister of emergency situations assured his people that their Earth-monitoring technology (satellites and seismographs?) showed no existential threats to the planet. He then correctly reminded them that they were still under threat from "blizzards, ice storms, torna-

does, floods, trouble with transportation and food supply, breakdowns in heat, electricity and water supply."

In an attempt to stanch this minor madness, the U.S. government issued a blog post reassuring the populace that the world would continue on schedule. The blog quotes NASA scientist David Morrison: "At least once a week I get a message from a young person—as young as 11—who says they are ill and/or contemplating suicide because of the coming doomsday." Little kids can get really spooked by stray talk from parents and other elders who may seriously contemplate the reality of the end of the world while never musing over how they're going to financially survive their years of retirement.

By the way, the governmental blog notes that "the world will not end on December 21, 2012, or any day in 2012." Way to commit to another 10 days of assured existence.

Meanwhile Australian prime minister Julia Gillard showed that she is a force to be reckoned with on the world stage. In a stone-faced video performance worthy of Buster Keaton or even Nicole Kidman, she says, "My dear remaining fellow Australians, the end of the world is coming. It wasn't Y2K. It wasn't even the carbon price. It turns out that the Mayan calendar is true.... Whether the final blow comes from flesh-eating zombies, demonic hell beasts or from the total triumph of K-pop [for Korean pop music; also see "PSY"], if you know one thing about me, it is this: I will always fight for you to the very end. And at least this means I won't have to do Q&A again. Good luck to you all."

Take a moment and imagine the reactions from various quarters if an American president had summoned the spirit to joke like that on television. At the very least, there would have been a run on bread, milk and batteries.

Most people have already probably forgotten the exciting end-of-the-world action of 2011, when May 21 was supposed to be "Rapture and Judgment Day," according to radio evangelist Harold Camping. I live in New York City, so I'm used to seeing the representatives of doomsday cults—why, on any given day you can still spot people wearing Mets caps. But even here in Sodom and Gomorrah, dozens of mostly young women were wandering around last year with "May 21st Judgment Day" signs.

I passed the same group of women a few days in a row in the long, low tunnel connecting Grand Central's East Side IRT subway trains with the shuttle to Times Square. Having poor self-control, I finally said to one, "You'll be here on the 22nd." And lo, she looked as if she were wont to smite me. Still, I hope her Christmas was joyous in 2012 and that her existential threat load is low in 2013. Same to you. ■

SCIENTIFIC AMERICAN ONLINE

Comment on this article at ScientificAmerican.com/feb2013

ON SALE NOW!

Get this special collector's edition.

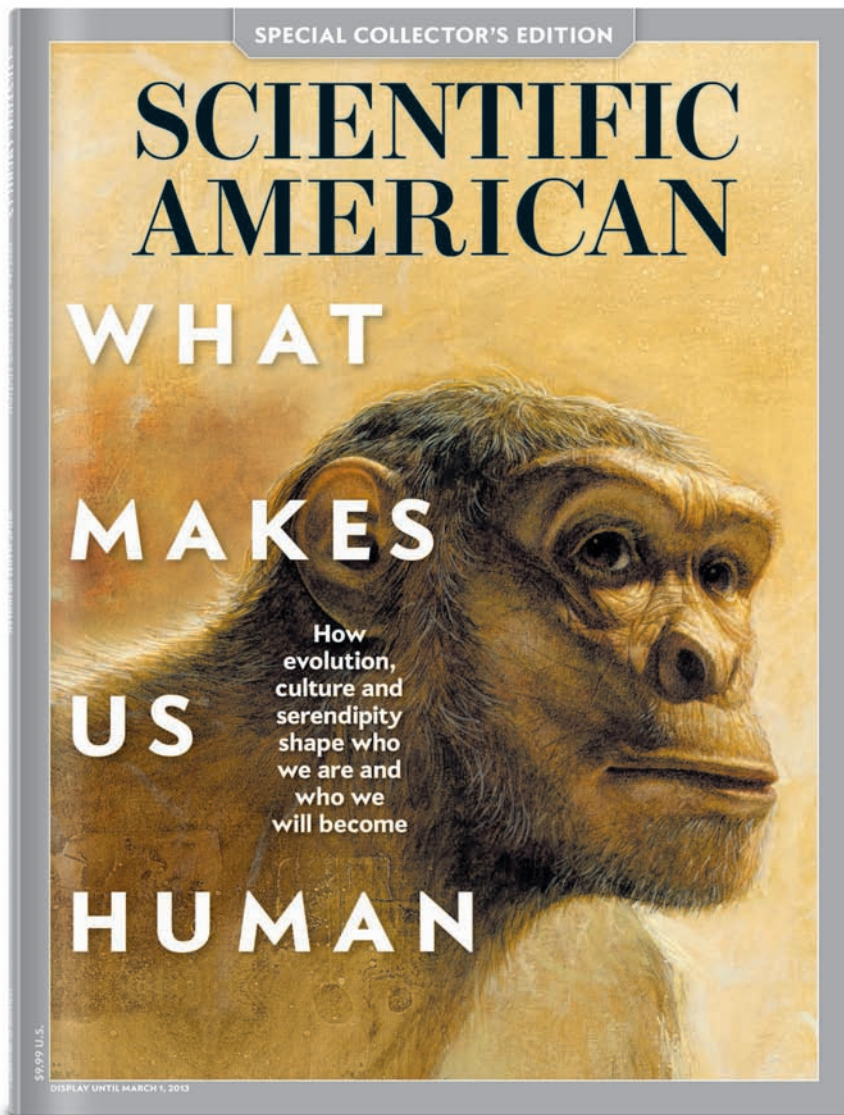

Available on newsstands.

Discover the latest research on what makes us different, the secrets of human survival and our continuing evolution with this special collection of over 15 in-depth feature articles. *What Makes Us Human* is available on newsstands for a limited time only. Get yours now.

**SCIENTIFIC
AMERICAN™**

YOUR
STORY
CAN
CHANGE
SOMEONE
ELSE'S.



ADDICTION IS HOPELESS WITHOUT YOU

Share your story of recovery or message of hope with someone who needs to hear it. Visit drugfree.org and join The Hope Share.

THE PARTNERSHIP[®]
[AT DRUGFREE.ORG](http://ATDRUGFREE.ORG)

SCIENTIFIC AMERICAN™

Publishing the latest in science and technology for more than 165 years

A site license provides online access to *Scientific American*,
Scientific American Mind and Special Issues



Recommend site license access to your library today:

www.nature.com/libraries/scientificamerican



February 1963

Smug Prosperity

“U.S. citizens—
known for their

material prosperity and a certain smug contentment in it—may be surprised to learn that samplings of public opinion in West Germany, Brazil and Cuba have shown that the peoples of these countries are even more buoyant about their recent progress and more hopeful of the future. Americans may be chastened as well to learn that these peoples also identify their personal wellbeing more closely with the fortunes of their countries. These very general statements represent the first findings of an experimental effort to develop a technique for making comparative studies, across national boundaries, of the concerns and aspirations of people around the world. —Hadley Cantril”



February 1913

Death of Scott

“In the desolate, icy waste of an unexplored Antarctic country
Capt. Robert Falcon

Scott gave up his life, after having reached the South Pole. He died a true hero of science. There was no buried treasure to seek in those untrodden southern snows—nothing but everlasting fame. Only those who are engaged in scientific research can understand the ideals of a man who willingly cuts himself off from the world for a period of three years and perishes in a blizzard—for what? For meteorological information, for geological data, for light on the fauna and flora of a cold, white, silent land that will probably never be peopled, in a word, for things that are infinitely removed from gold hunting.”

Paintings at Altamira

“Why should the primitive artists of the paleolithic paintings at Altamira

have chosen to decorate the darker recesses of their dwellings, rather than practice their art where the light of the sun would have helped them? It seems probable that the paintings were made not for the love of beauty, or to ‘show the hand’ of paleolithic Giotto, but with strictly business aims. They were, in fact, primitive pot-boilers, done to supply the larder with material. One hypothesis is that the paleolithic man of Southern Gaul and Northern Spain believed in his own paintings of deer, boars, aurochs, horses (considered good eating) and mammoths as potent to attract the animals themselves.”

Airplane Stability

“The most recent machine having automatic stability is the Drzewiecki following-surface monoplane [see illustration], which was exhibited at the last Paris Salon. This machine is of the Langley type. Its chief point of interest is that the wings are set at a 3-degree difference. The result is the production of righting forces that counteract diving and keep the machine on an even keel. The machine was designed as the result of experiments made in the Eiffel aerodynamic laboratory.”

See a slide show of aviation in 1913 at www.ScientificAmerican.com/feb2013/aviation

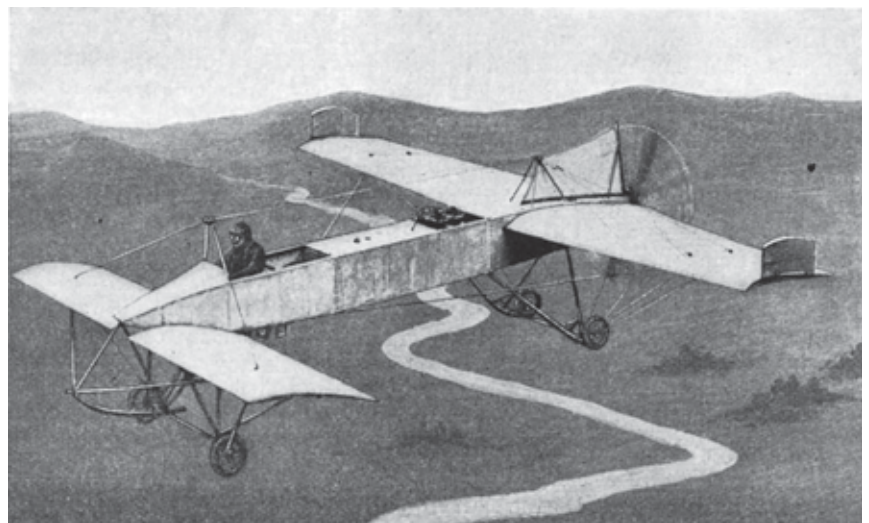

STABLE AIRPLANE DESIGN: The gifted Polish inventor Stefan D. Drzewiecki was known for his work on propellers, submarines and this interesting airplane, 1913



February 1863

Shocking Statistics

“The suicides in
France now average

ten a day. Not a day passes in which a suicide may not be directly traced to want of success in life; to the false moralities inculcated by wicked or ignorant writers; to the failure of parents in obtaining a proper influence over their children; and to unrestrained appetites and passions.”

Good Eats in Iceland

“In Iceland daily food consists chiefly of raw, dried stockfish and ‘skier.’ The latter dish is milk allowed to become acid and coagulate, and then hung up in a bag till the whey runs off. In this form it is both nutritive and wholesome, being more easily digested than sweet milk. To those who take to it, it is light, palatable, and delightfully cooling. Milk is prepared in this way by Shetlanders, who, in the first stage, call it ‘run milk,’ and when made into skier, ‘hung milk.’ Our idea, that milk is useless and hurtful when sour, is merely an ignorant prejudice. Those who depend for their subsistence chiefly on a milk diet prefer to use it sour, and medical authority endorses their choice.”

Adopt Me.

And change my world.



THE DIAN FOSSEY
GORILLA FUND
INTERNATIONAL

There are fewer than 800 mountain gorillas left on the planet.
Together we can save them.

Give A Gift to Yourself or to Someone You Love

gorillafund.org/adopt-a-gorilla

| 1 (800) 851 0203

Rising Risks

A survey of leaders shows growing concern over consequences of science and technology

The economy has dominated the headlines for years, but unforeseen consequences of life sciences and climate change mitigation are also beginning to weigh heavily on people's minds. The World Economic Forum experts and industry leaders have gauged the likelihood and potential impact of 50 risks of global significance (the 2013 *Global Risks Report* came out in January). We have arranged each risk according to how much views have changed in the past year (with the biggest combined increase in estimated likelihood and potential impact at the upper left of the page); orange shading highlights science and technology concerns. Population, species loss, weapons of mass destruction, pollution and information technology figure prominently. Climate change, including worries over greenhouse gas emissions and adaptation, also factor in significantly.

—Fred Guterl

SCIENTIFIC AMERICAN ONLINE

For an interactive version of the report, see ScientificAmerican.com/feb2013/graphic-science

Likelihood (left hemisphere)
Impact (right hemisphere)



1 Hard landing of an emerging economy

Rank, according to degree of change, from largest increase to largest decrease, in overall risk (combining likelihood and impact ratings) between 2012 and 2013

Red: Perceived risk has increased
Blue: Perceived risk has decreased

Large grey quarter: Largest relative change (entire quarter filled)
Thin grey line: Smallest relative change

Circle size: Reflects relative extent of assessed risk when likelihood and impact ratings are combined

Worry meters reflect risk assessments relating to 50 global problems

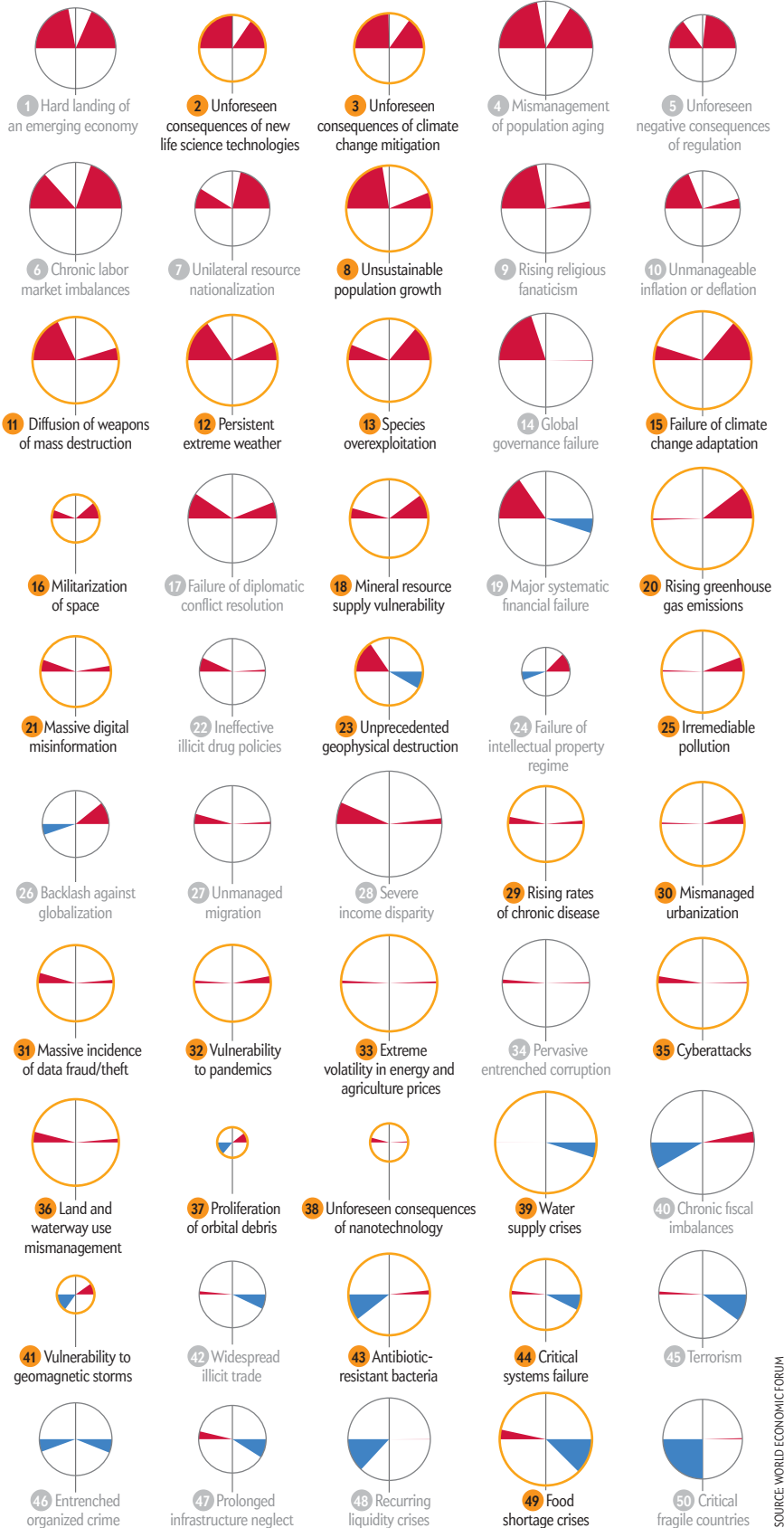

SOURCE: WORLD ECONOMIC FORUM

Albert Einstein, age 16.

An early fascination with magnets
led to his famous $E=mc^2$

You're never too young
to change the world.

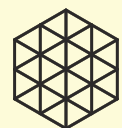

Google
Science
Fair 2013

googlesciencefair.com



The LEGO Group



SCIENTIFIC
AMERICAN



Determination is in our nature

Finding oil used to be easy. So was recovering it. Today, oil exploration requires highly specialized skills to deal with the vast challenges we are facing, like unfathomable depths and complicated geology. When we find the oil, it can be difficult to recover due to high pressure and low permeability. And most importantly, we have to meet the world's toughest safety standards – our own. Luckily, we have a secret weapon; our attitude of constantly raising the bar on everything we do. Or as we like to call it – never being satisfied.

