



28 HOT PRODUCTS Time to Upgrade! p. 28

THE ESSENTIAL GUIDE TO ASTRONOMY

SKY & TELESCOPE

JANUARY 2015

Investigative Report:

Big Hurdles for Big Scopes

p. 60

Backyard Winter Beauties p. 36

Hubble's New Gravity Glasses p. 20

See Mercury & Venus Pair Up p. 48

Lacaille's Furnace Brightens p. 56

HOW TO
Compose & Create
Striking Astrophotos p. 70

Visit SkyandTelescope.com

Reader Challenge:
Catch a Unique
Stellar Eclipse p. 50



fw US \$5.99

0 74808 02207 6 01

Display until December 29, 2014

Download Our Free SkyWeek App

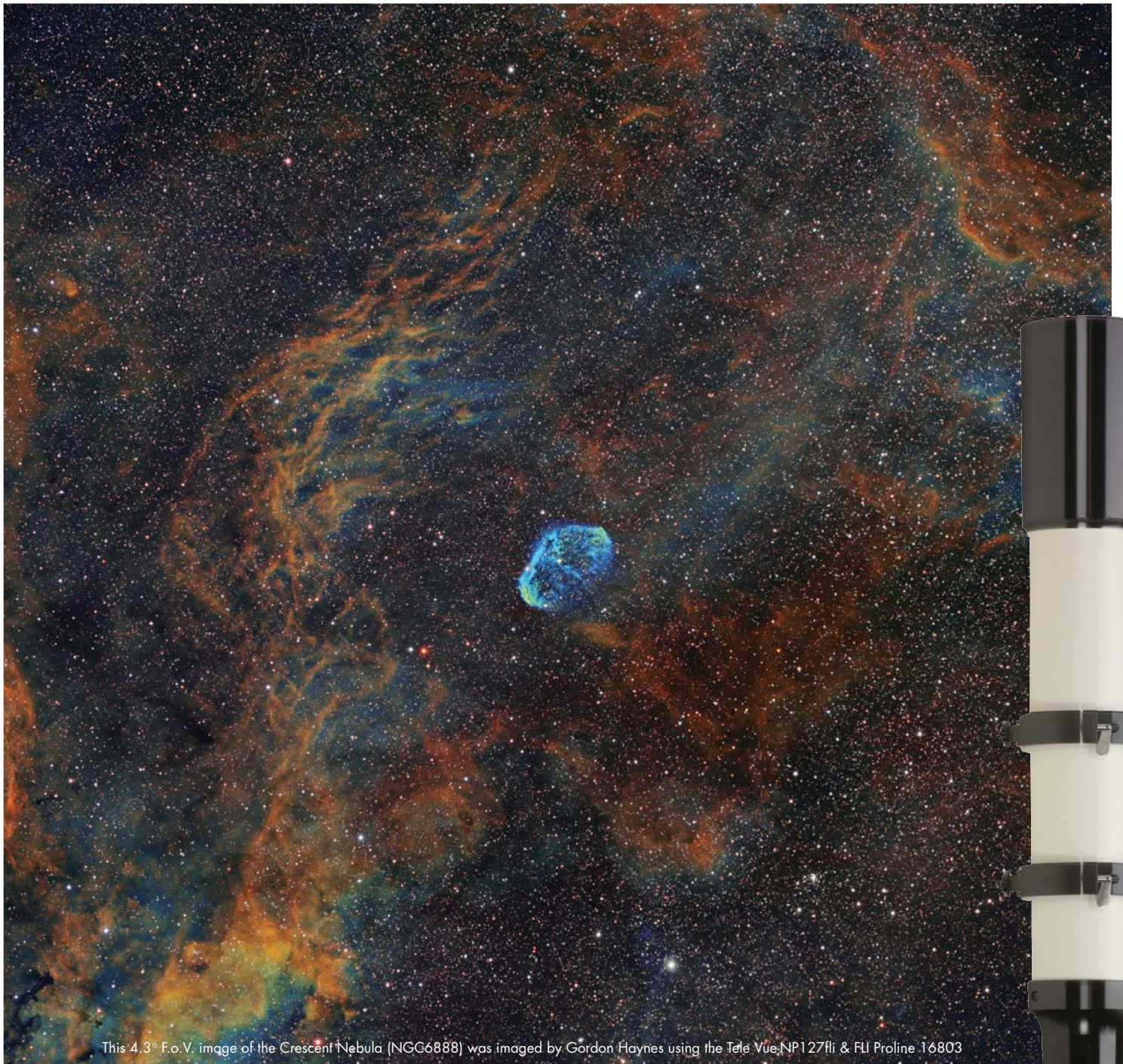

This 4.3° F.o.V. image of the Crescent Nebula (NGC6888) was imaged by Gordon Haynes using the Tele Vue-NP127fli & FLI Proline 16803

“Truly Plug and Play!”

Astroimaging still isn't “point & shoot,” but as Gordon says, it is finally “plug & play.” “I've never used such an easy to set up and use, trouble free imaging set up, not to mention the quality of the images! With my other scopes I'd have to interrupt sessions to adjust focus, not with the NP127fli. It simply allows more quality data gathering time. I would go as far as saying it is, without doubt, the best widefield astrograph available.” The Tele Vue-NP127fli marries its flat-field, f/5.3 optics with FLI's Atlas Focuser, Centerline Filter Wheel, and Proline series cameras to create a system that simply locks together rigid, square and properly spaced. Engineered as a system, there is nothing to figure out, source, or tweak. The work is done, just go image! See more images and learn about the unique features of the NP127fli at TeleVue.com



32 Elkay Dr., Chester, New York 10918 (845) 469-4551 . televue.com



A STAR IS BORN

Bob Ophiuchus's image taken with SBIG STX-16003 camera and processed with Maxim DL software. - Courtesy Tony Hallas



SBIG is now a division of

 *Diffraction Limited*

"The combination of high quality SBIG instruments with our industry-leading software will create the ultimate astronomical imaging solution."
- Doug George, President/CEO, Diffraction Limited.

"The resulting tighter integration of software and hardware can only benefit existing and future customers."
- Dr. Alan Holmes, SBIG.

"We could not have asked for a better combination than SBIG's innovative hardware and Diffraction's cutting edge software."
- Michael Barber, SBIG.

SBIG division of Diffraction Limited, 59B Grenfell Crescent, Ottawa, ON K2G 0G3, Canada www.sbig.com





On the cover:
Like its big-scope brethren, the Gran Telescopio Canarias has overcome big obstacles.

PHOTO:
PABLO BONET / IAC

FEATURES

- 20 Hubble Goes the Distance**
Using nature's gravitational lenses, astronomers are pushing the space telescope to its very limits to reveal primordial galaxies.
By Gvoert Schilling
- 28 Hot Products for 2015**
Our 17th annual roundup of Hot Products highlights the most intriguing new astronomy gear in the market.
By the Editors of Sky & Telescope
- 36 The Backyard Sky: Winter**
Embrace the cold nights of winter to observe these seasonal delights.
By Rod Mollise
- 60 Flawed Giants**
The world's largest optical telescopes have had to overcome serious hurdles, delaying their scientific successes. *By Robert Zimmerman*
- 70 Composing the Universe**
Planning your composition can raise your imaging to a whole new level.
By Robert Gendler

**COVER
STORY**

OBSERVING JANUARY

- 43 In This Section**
- 44 January's Sky at a Glance**
- 45 Binocular Highlight**
By Gary Seronik
- 46 Planetary Almanac**
- 47 Northern Hemisphere's Sky**
By Fred Schaaf
- 48 Sun, Moon & Planets**
By Fred Schaaf
- 50 Celestial Calendar**
By Alan MacRobert
- 54 Exploring the Solar System**
By Thomas A. Dobbins
- 56 Deep-Sky Wonders**
By Sue French

ALSO IN THIS ISSUE

- 6 Spectrum**
By Peter Tyson
- 8 Letters**
- 10 75, 50 & 25 Years Ago**
By Roger W. Sinnott
- 12 News Notes**
- 18 Cosmic Relief**
By David Grinspoon
- 68 Telescope Workshop**
By Gary Seronik
- 75 Gallery**
- 86 Focal Point**
By Bob Guzauskas & Colin Henshaw



Keck Observatory

60

NASA / T. WYNNIE / JPL

There's more to find online @
SkyandTelescope.com

EQUIPMENT GUIDES

Find advice on choosing the best tools to equip your backyard astronomy adventures.

SkyandTelescope.com/equipment/basics

TIPS FOR BEGINNERS

New to astronomy? Here's everything you need to jump into the fun.

SkyandTelescope.com/letsgo

SKY ON THE GO

Find information about all our skygazing apps, from SkyWeek to JupiterMoons.

SkyandTelescope.com/SkyApps

EBOOK LIBRARY

Enjoy our growing collection of eBooks, on subjects from Saturn to meteor showers.

SkyandTelescope.com/eBook

ASTRONOMY EVENTS

Check out our events calendar for upcoming museum exhibits, star parties, and more — or add your own event to our listings!

SkyandTelescope.com/astronomy-events

SKY & TELESCOPE (ISSN 0037-6604) is published monthly by F+W Media, Inc., 90 Sherman St., Cambridge, MA 02140-3264, USA. Phone: 800-253-0245 (customer service/subscriptions), 888-253-0230 (product orders), 617-864-7360 (all other calls). Fax: 617-864-6117. Website: SkyandTelescope.com. © 2015 F+W Media, Inc. All rights reserved. Periodicals postage paid at Boston, Massachusetts, and at additional mailing offices. Canada Post Publications Mail sales agreement #40029823. Canadian return address: 2744 Edna St., Windsor, ON, Canada N8Y 1V2. Canadian GST Reg. #R128921855. POSTMASTER: Send address changes to Sky & Telescope, PO Box 420235, Palm Coast, FL 32142-0235. Printed in the USA.



Find us on
Facebook & Twitter

Filling bigger spaces with smaller projectors



After nearly 60 years in smaller quarters, GOTO INC built our current factory in the western suburb of Fuchu in 1984. It includes two test domes, including an 18 meter (59 foot) diameter dome for work on the most powerful projectors. This dome has a 30 degree tilt, no seats, and a minimal sound system. For the past 30 years, this is where many generations of large planetarium projectors have been prototyped and tested. It is also the birthplace of modern full-dome video - where GOTO's VIRTUARIUM was first demonstrated in the summer of 1996.

Typically there are several projectors and full-dome systems here at any one time. Stacks of equipment boxes and racks of computers fill the upper level of the room. This working dome may not be the prettiest planetarium in the world, but wait until the lights go out and the GOTO projectors come on. Then be prepared for "awesome" to happen!

In this photo, you see our newest projector, the ultra-compact CHIRON III in the center of the dome. This 480mm (19 inch) starball now does the job of the much larger, older SUPER HELIOS projector seen on the floor below. The CHIRON III's super-bright LED illumination, fiber optics, and a totally new optic design lets this little projector fill domes up to 30 meters (98 feet) in diameter, beautifully!

CHIRON III features smaller yet brighter stars, and scintillation that can be controlled by the operator. ALL CHIRON III stars show true color temperature, and the long-life LEDs which power them allow for extremely quiet cooling fans. So our larger factory now makes smaller projectors!

**GOTO HYBRID PLANETARIUM
CHIRON III**

GOTO INC

4-16 Yazakicho, Fuchu-shi, Tokyo

183-8530 Japan

Tel : +81-42-362-5312

Fax: +81-42-361-9571

E-Mail : Info2@goto.co.jp

URL: www.goto.co.jp/index-e.html

GOTO USA LIAISON

5715 Susan Drive East

Indianapolis, IN 46250

Tel: +1-317-537-2806

E-Mail: gotousa@earthlink.net Contact : Ken Miller





January 2015 Digital Extra

BONUS WEB CONTENT

- **Mergers Create Pancake Galaxies**
Watch two galaxies collide and see what radio astronomers would see.
- **Fighting for Dark Skies**
Learn more about one club's battle against light pollution.
- **Mutual Events Among Jupiter's Moons**
Find out how to watch Jovian moons eclipse and occult one another.



Photo Gallery

Image by Reza Mofazely



ASTROPHOTOGRAPHY ONLINE CLASS

EXPLORE OUR WEBSITE!

- **Getting Started**
New to astronomy? Find out what resources we have to offer.
- **Astronomy Events**
Find a star party or museum opening near you — and list your own club's activities too!
- **Join an Astronomy Club**
Get involved in the amateur community — find an astronomy club near you.

TOUR THE SKY – ASTRONOMY PODCASTS

OBSERVING HIGHLIGHTS

Sign up for **Newsletters** and **AstroAlerts**

THIS WEEK'S Sky at a Glance



DOWNLOAD OUR OBSERVING APPS



SKY & TELESCOPE SOLAR SYSTEM COLLECTION MARS



New in Shop @ Sky

DIGITAL BACK ISSUES:
October, November, and December



Find us on Facebook & Twitter



ONLINE PHOTO GALLERY

David Fedorko caught this shot of the partial solar eclipse on October 23, 2014.





High Standards

ONE EVENING IN EARLY SEPTEMBER, not long after

I accepted this position, Bob Naeye, my predecessor, graciously invited me to pay a visit with him to Mario Motta. A committed amateur, Mario built an impressive 32-inch reflector in a rooftop observatory at his home in Gloucester, Mass. (*S&T*: May 2011, p. 32). As we sat on his porch later that evening — a bright moon had curtailed our observations — Mario asked me what my plans were for the magazine. Before I could answer, he added, “I have one request: don’t dumb it down.”

I answered him, and I’ll answer you, our readers: I have no intention whatsoever of doing that. I feel privileged to be furthering the legacy that Charles Federer began in 1941 when he launched *Sky & Telescope*, which many of us grew up with in our living rooms. It’s like owning an object of historical value: you have a responsibility to care for it properly before passing it on to the next steward. My goal is to continue striving to meet the needs of intermediate to advanced amateurs so that — to quote Federer when he assumed editorship of *The Sky* in 1940 — “amateur astronomers will come to regard it as essential in their pursuit, and professionals to consider it a worthwhile medium in which to bring their work before the public.”

That said, I do plan to try my best — as many of you do all the time — to pique the interest of the next generation of amateur astronomers. To accomplish that in our swiftly evolving digital world, we have to go where they go. We will need to think more online, more mobile, more video. That doesn’t mean dumbing down, in the sense of avoiding in-depth material. No: the technical level and sophistication you have come to rely on will remain. We just need to provide that information in new ways.

But make no mistake: even as I will be giving special thought to future readers, I will work as closely as my predecessors with *S&T*’s talented editorial and design team to continue publishing the authoritative magazine you know and love — *as you know and love it*.

I have a lot to learn from colleagues, from long-time contributors, and, most importantly, from you, our readers. If you’d like to share your thoughts on *Sky & Telescope*, in any of its forms, please email me at ptyson@skyandtelescope.com. I may not get back right away, as things are busy around here, but I will get back.

Editor in Chief



Founded in 1941
by Charles A. Federer, Jr.
and Helen Spence Federer

The Essential Guide
to Astronomy

EDITORIAL

Editor in Chief **Peter Tyson**
Senior Editor **Alan M. MacRobert**
Imaging Editor **Sean Walker**
Science Editor **Camille M. Carlisle**
Web Editor **Monica Young**
Equipment Editor **John S. Gianforte**
Observing Editor **Susan N. Johnson-Roeher**

Senior Contributing Editors **J. Kelly Beatty, Robert Naeye, Roger W. Sinnott**

Contributing Editors **Jim Bell, Trudy Bell, John E. Bortle, Greg Bryant, Thomas A. Dobbins, Alan Dyer, Tom Field, Tony Flanders, Ted Forte, Sue French, Steve Gottlieb, David Grinspoon, Ken Hewitt-White, Johnny Horne, Emily Lakdawalla, Rod Mollise, Donald W. Olson, Joe Rao, Dean Regas, Fred Schaaf, Govert Schilling, Gary Seronik, William Sheehan, Mike Simons, Alan Whitman, Charles A. Wood, Robert Zimmerman**

Contributing Photographers **P. K. Chen, Akira Fujii, Robert Gendler, Babak Tafreshi**

ART & DESIGN

Design Director **Patricia Gillis-Coppola**
Illustration Director **Gregg Dinderman**
Illustrator **Leah Tiscione**

PUBLISHING AND MARKETING

Advertising Sales Director **Peter D. Hardy, Jr.**
Advertising Services Manager **Lester J. Stockman**
IT Manager **Denise Donnarumma**
Consumer Marketing **Joseph Izzo**

F+W, A CONTENT + ECOMMERCE COMPANY

Chairman & CEO **David Nussbaum**
CFO & COO **James Ogle**
President **David Blansfield**
Chief Digital Officer **Chad Phelps**
VP / E-Commerce **Lucas Hilbert**
Senior VP / Operations **Phil Graham**
VP Communications **Stacie Berger**
Director of Magazine Marketing & Fulfillment **Mark Fleetwood**

Editorial Correspondence: *Sky & Telescope*, 90 Sherman St., Cambridge, MA 02140-3264, USA. Phone: 617-864-7360. Fax: 617-864-6117. E-mail: editors@skyandtelescope.com. Website: [SkyandTelescope.com](http://skyandtelescope.com). Unsolicited proposals, manuscripts, photographs, and electronic images are welcome, but a stamped, self-addressed envelope must be provided to guarantee their return; see our guidelines for contributors at skyandtelescope.com.

Advertising Information: Peter D. Hardy, Jr., 617-864-7360, ext. 2133. Fax: 617-864-6117. E-mail: peterh@skyandtelescope.com. Web: skyandtelescope.com/advertising

Customer Service: Magazine customer service and change-of-address notices: skyandtelescope@emailcustomerservice.com. Phone toll free U.S. and Canada: 800-253-0245. Outside the U.S. and Canada: 386-597-4387. Product customer service: skyprodservice@skyandtelescope.com. Phone toll free: 888-253-0230.

Subscription Rates: U.S. and possessions: \$42.95 per year (12 issues); Canada: \$49.95 (including GST); all other countries: \$61.95, by expedited delivery. All prices are in U.S. dollars.

Newsstand and Retail Distribution: Curtis Circulation Co., 730 River Rd., New Milford, NJ 07646-3048, USA. Phone: 201-634-7400.

SKY & TELESCOPE (ISSN 0037-6604) is published monthly by Sky & Telescope, a division of F+W Media, Inc., 90 Sherman St., Cambridge, MA 02140-3264, USA. Phone: 800-253-0245 (customer service/subscriptions), 888-253-0230 (product orders), 617-864-7360 (all other calls). Fax: 617-864-6117. Website: skyandtelescope.com. © 2015 F+W Media, Inc. All rights reserved. Periodicals postage paid at Boston, Massachusetts, and at additional mailing offices. Canada Post Publications Mail sales agreement #40029823. Canadian return address: 2744 Edna St., Windsor, ON, Canada N8Y 1V2. Canadian GST Reg. #R128921855. POSTMASTER: Send address changes to Sky & Telescope, PO Box 420235, Palm Coast, FL 32142-0235. Printed in the USA.

The following are registered trademarks of F+W Media, Inc.: *Sky & Telescope* and logo, *Sky and Telescope*, *The Essential Guide to Astronomy*, *Skyline*, *Sky Publications*, *SkyandTelescope.com*, <http://www.skypub.com/>, *SkyWatch*, *Scanning the Skies*, *Night Sky*, *SkyWeek*, and *ESSCO*.

LX600™ WITH STARLOCK™

EASIER TO USE. EASIER TO MOVE. SMART.

The LX600 f/8 ACF with StarLock technology takes a giant leap forward by making astro-imaging easier and making setup and transportation a breeze. The LX600 is a simple to operate, portable package that makes taking great astro-photos as easy as focusing your camera and opening the shutter.

+ FASTER, SHARPER OPTICAL SYSTEM

The LX600 employs a fast f/8 ACF™ optical system with high-contrast baffling that assures crisp, pinpoint imaging to the very edge of the field. The all-new OTA features an internal Crayford-style, zero image-shift focusing system with a two-speed, 7:1 control.

+ STARLOCK — FULL-TIME AUTOMATIC GUIDING

Full-time completely automatic guiding and closed loop Ultra High Precision Pointing. The LX600 StarLock system delivers long-exposure guiding without the hassle.

+ X-Wedge™

Precision machined aluminum for maximum stability with smooth, accurate altitude and azimuth adjustments. The X-Wedge is the essential accessory for polar mounting the LX600 for long exposure astrophotography.

+ PORTABILITY & TRANSPORTATION

With the LX600 Split Fork design the OTA can be quickly separated from the mount, reducing the total weight that must be lifted at one time by 35 lb. This allows for easy setup and transportation even with a 12" or 14" OTA.



Shown with 10" ACF f/8 OTA
On Optional X-Wedge
\$4,999



10" LX600 — Starting at \$4,499
12" LX600 — Starting at \$5,499
14" LX600 — Starting at \$7,999
16" LX600 — Starting at \$16,499
Optional X-Wedge — \$699

OPT Telescopes
800.483.6287
www.optcorp.com

B & H Photo
800.482.8143
www.bhphotovideo.com

Telescopes.com
800.303.5873
www.telescopes.com

Woodland Hills
888.427.8766
www.telescopes.net

Adorama
800.223.2500
www.adorama.com

Optics Planet
800.504.5897
www.opticsplanet.com

High Point Scientific
800.266.9590
www.highpointscientific.com

Astronomics
800.422.7876
www.astronomics.com

Canada • Khan Scopes
800.580.7160
www.khanscope.com

 **MEADE** INSTRUMENTS

www.meade.com



Earthshine in an Early Telescope

I am writing to express my appreciation for the very enjoyable article on earthshine by Kelly Beatty in the July issue (p. 54). Although this is a very simple phenomenon and accessible to everyone with the naked eye, its current use to monitor Earth's climate (as Beatty described) is quite brilliant.

Earthshine is particularly interesting in regard to the history of astronomy. As I suggest in my recent article in the journal of Galilean studies *Galilæana*, it is quite possible that Galileo first turned his telescope to the sky in order to study the nature of this strange and controversial light. One of the first detailed descriptions of the phenomenon appears in his *Starry Messenger* (March 1610). However, there he writes that he had found the explanation for earthshine many years earlier. Although he was not the first to suggest the glow came from Earth, he potentially delayed writing about it because the correct interpretation is strongly anti-Aristotelian: the sunlight reflected by Earth to the Moon and back again puts in communication the corrupted sub-lunar world with the uncontaminated world of the celestial spheres. Historians familiar with the work's creation suggest that the earthshine passage, together with the dedication to Cosimo de' Medici and the conclusions, were added only in the final stage of the book's hurried preparation.

Galileo also painted watercolors to illustrate what he saw with the telescope. The first documented observation is that of November 30, 1609. This watercolor clearly shows a crescent Moon, with the nightside of the Moon wrapped in the soft light of earthshine. But unlike the watercolors, the etchings in the book do not show the same feature. If Galileo indeed decided to discuss it only at the last moment, there might not have been time to replace the etchings: being extremely concerned with primacy in discovery, he might not have wanted to delay the press.

Paolo Molaro
Trieste, Italy

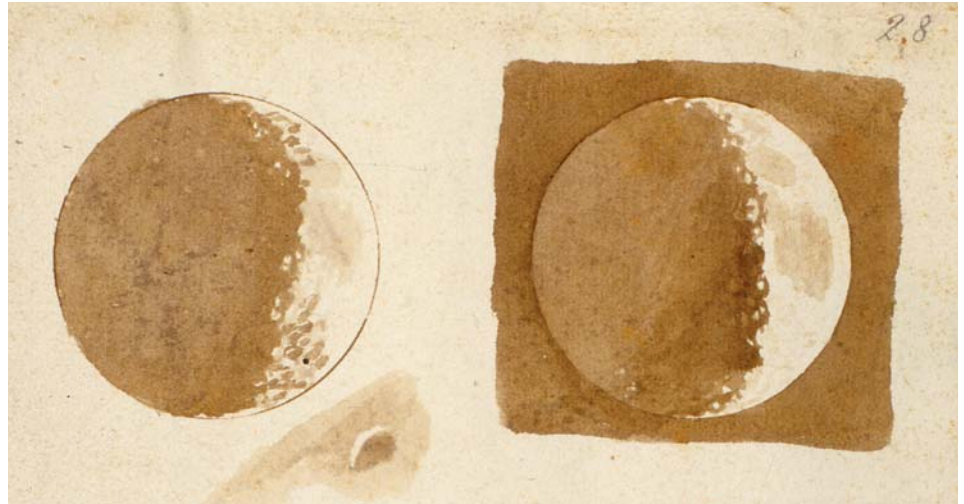

Watercolors by Galileo show lunar details illuminated by earthshine.

Experiencing Craters on Earth

The August *S&T* had two articles about lunar craters, including Charles Wood's column on how to find and view elevation information (p. 54). To have a sense of these features' scale, it helps to find places on Earth that have similar distances and elevations. It turns out that driving highway I-25 near Pueblo, Colorado gives such a perspective. If you are in Pueblo at 4,700-foot elevation, which is about 70 miles south of Pikes Peak (14,000 ft), the elevation change and distance between the two is very similar to what you'd see if standing on the northernmost part of Fracastorius Crater's low floor and looking at its high southern rim.

I used to work in Pueblo and saw Pikes Peak — as well as East (12,700 ft) and West (13,600 ft) Spanish Peak 90 miles south of Pueblo — on the drive to work every day. The sense that, "Hey, this is how I might see the edge of a crater from inside if I were on the Moon," was one of those wonder experiences. What other settings also give a feel for the size and elevation of lunar craters?

Rick Stewart
Placerville, California

I was interested to read William Sheehan's August *S&T* article on how explosion craters helped reveal lunar craters' origin (p. 28). You are probably unaware of the biggest manmade, non-nuclear explosion

of WWII (presumably in all history) — in part because it was kept hush-hush until the end of the war. The Fauld Crater is about 40 miles south of where I live in north Staffordshire and resulted from the accidental detonation of nearly 4,000 tons of bombs stored in a gypsum mine . . . for safekeeping! The explosion killed about 80 people and vaporized a farm, a reservoir, and a herd of cows.

Since about 1998 I have visited the site on multiple occasions. There is no ejecta rim; in fact, the crater is difficult to find until you reach its northwest corner, following paths from the nearby Cock Inn at Hanbury. The inn was nearly blasted flat by the detonation and now contains some interesting local newspaper cuttings from the time. The crater is roughly 1,000 feet across at its widest point and is too big to photograph in its entirety from ground level, although you can see it well on Google Earth: <https://goo.gl/maps/A57uc>. No one is allowed into the crater because of the danger of unexploded bombs, so a completely autonomous ecosystem has now arisen inside it.

Kevin Kilburn, FRAS
Cheddleton, Staffordshire Moorlands,
United Kingdom

Be Ever Vigilant

We have an extensive enclave of professional and amateur observatories here in the extreme southeast of Arizona. Our lat-

Now on SALE
for the holidays!

SkyTracker™

Take beautiful photos of the night sky
just like a pro!

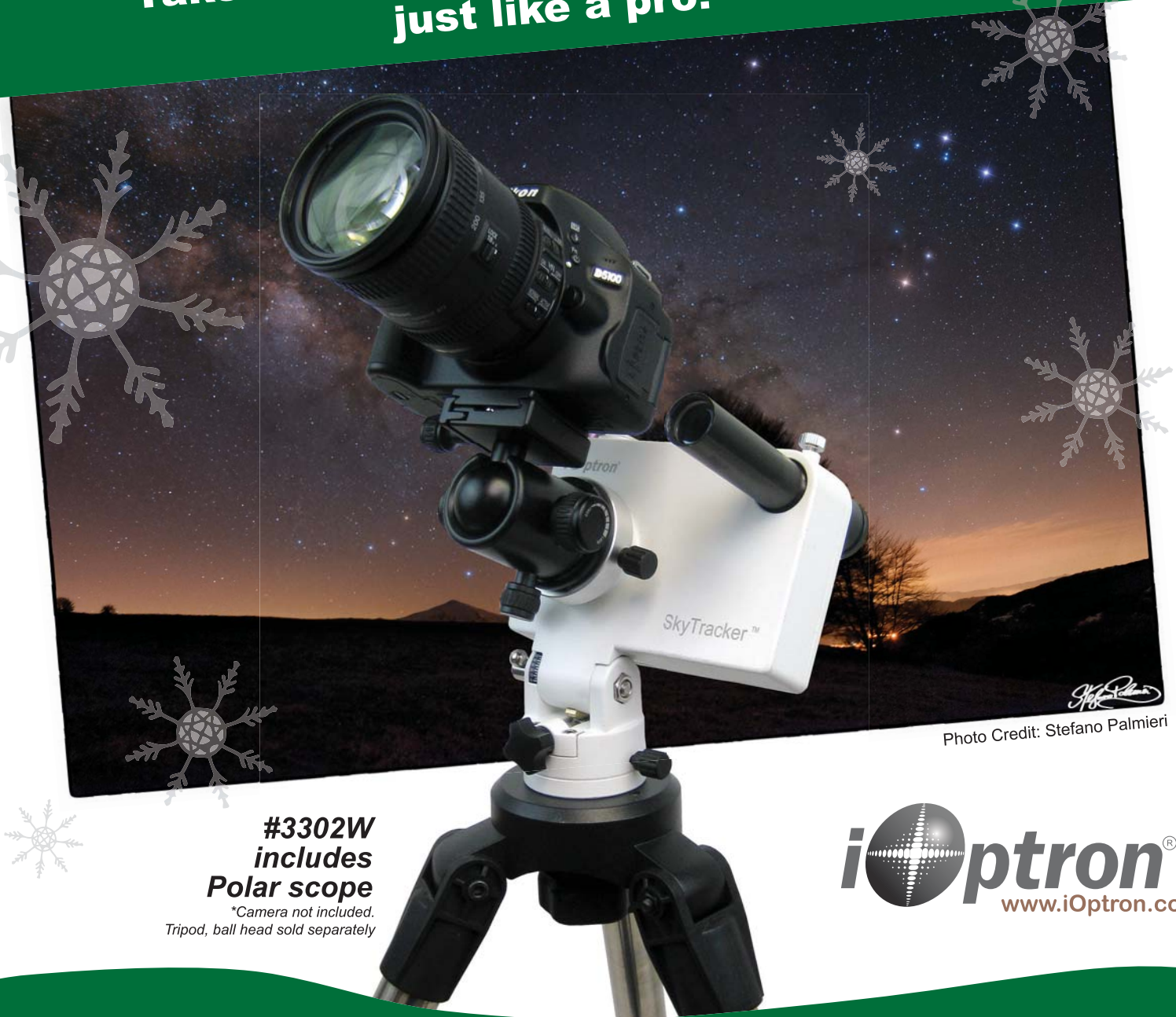

Photo Credit: Stefano Palmieri

**#3302W
includes
Polar scope**

**Camera not included.
Tripod, ball head sold separately*

iOptron®
www.iOptron.com

Featured Dealers:

Visit www.iOptron.com
for a complete list of dealers

B&H Photo 1.800.606.6969 www.bhphotovideo.com
Astronomics 1.800.422.7876 www.astronomics.com
High Point Scientific 1.800.266.9590 www.highpointscientific.com
OPT 1.800.483.6287 www.opttelescopes.com
Telescopes.com 1.800.303.5873 www.telescopes.com
Woodland Hills Telescopes 1.888.427.8766 www.telescopes.net
(Canada) Ontario Telescope 1.905.487.6363 www.ontariotelescope.com

est survey of observatories puts the number at about 50 in and around Cochise County. We moved here because of the clear, dark, steady skies, and the presence of city, county, and state governments that understand our needs.

Because of the continued commitment of the county's planning staff to retain the area's rural character and natural beauty, and of the determination of Huachuca Astronomy Club of Southeastern Arizona to keep our night skies dark, we have a revised county light-pollution code that squarely confronts LED signage.

In August, Lowell Observatory hosted a summit called "Blinded by the Light" to discuss the impacts of LED lighting and other technologies on astronomy, health, and public safety. During the discussion of the county's light-pollution code revisions, a county planning staffer was asked about what he had learned from attending the

summit. He said that he had expected to learn a lot from other governmental agencies at the conference, but instead found that the code on which he was working — which speaks to signage size, height, total light output, allowable colors and LED temperature, light trespass, and more — was on the leading edge, not playing catch-up.

The situation at the city level is not so positive. The city of Sierra Vista has had good laws to limit night lighting and signage. But outside money has an allure that can trump quiet, obedient citizens. A fast-food restaurant wanted a bright programmable LED message display — the kind with a matrix of lights that creates pictures and scrolling banners — as part of its signage for its upcoming store in town. A city-level "special planning department working group" formed to discuss a future that included these signs, which are currently prohibited by city laws.

Write to Letters to the Editor, *Sky & Telescope*, 90 Sherman St., Cambridge, MA 02140-3264, or send e-mail to letters@SkyandTelescope.com. Please limit your comments to 300 words. Published letters may be edited for clarity and brevity.

Our club's past president was on the working group, or we would have been blindsided. We've done outreach programs and shown up at committee meetings in force, and our letter-writing campaign has gathered support from local nature and wildlife clubs, international dark-sky groups, and world-class observatories. The outcome remains to be seen.

You can find out more on our club website: www.hacastronomy.com. Just remember: it can happen to you.

*David Roemer, club president
Sierra Vista, Arizona*

75, 50 & 25 Years Ago

January 1940

A Better Lap "Among the several types of laps used in polishing telescope mirrors are the traditional one made up of one-inch squares of pitch, the H.C.F. (honey-comb foundation) of Wally Everest, and that of Dr. Henry L. Yeagley [using a perforated rubber mat]. The last [as here described] is quite rapid and easy to make. . . .

"For the benefit of those who have made mirrors before and have used older techniques for forming and patterning the pitch lap, a list of [some of] the new lap's advantages is given:

"1. The water-rouge mixture is retained almost indefinitely. Polishing may continue easily for an hour or more without interruption.

"2. The larger amount of water-rouge mixture present acts as an effective heat distributor and levels off temperature differences over the surfaces.

"3. The danger of scratching the mirror edge or other zones is negligible."

Walter Howland also explained in detail how to cast a pitch lap with the perforated rubber mat. His article didn't settle the debate over the ideal lap, but it did launch a new monthly column, Gleanings for ATMs, which

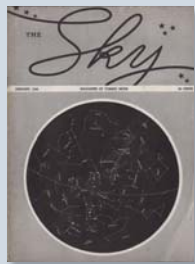

Roger W. Sinnott

complemented Albert G. Ingalls's similar column in Scientific American. The department continues today as Telescope Workshop (see page 68).

January 1965

Spectral Mystery "In the spectra of many hot stars are observed narrow dark lines, due to the absorption of light by the highly rarefied interstellar gas. Sodium, calcium, and iron atoms are among the constituents of this gas. But for the past 30 years, there has been considerable discussion about the identification of a broad, diffuse interstellar absorption feature, centered on 4430 angstroms wavelength. Now, Charles A. Whitney at the Smithsonian Astrophysical Observatory suggests that ice-coated sodium particles may be responsible. . . .

"Whether metallic sodium grains coated with ice can be produced in interstellar space is not known. The predicted number of particles required to cause the observed band intensities is about one per 100 cubic meters, a value not inconsistent with present data."

There is still no consensus about what produces the hundreds of diffuse interstellar bands

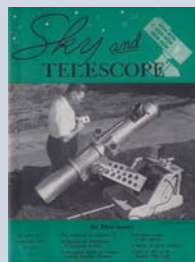

now known, but certain complex hydrocarbon molecules are a strong candidate.

January 1990

Biggest Thing "The discovery of what is hailed as the largest coherent structure in the universe, a 'wall' of thousands of galaxies at least 500 million light-years long, made front-page headlines late last year. The Great Wall of galaxies forms an arc stretching from at least 8 to 17 hours of right ascension. . . . It is the latest and largest example of enormous strings of galaxies separated by giant voids that Margaret J. Geller and John P. Huchra (Harvard-Smithsonian Center for Astrophysics) have discovered. . . .

"[F]eatures on such enormous scales pose severe problems for theories that describe how galaxies and clusters of galaxies formed. The 'wall,' for example, is too large . . . to have resulted from the mutual gravitational attraction of its constituent galaxies acting over the age of the universe."

Cosmologists now think such large arrangements of galaxies came about naturally in the early universe. But structures that are three times bigger await solid explanation.

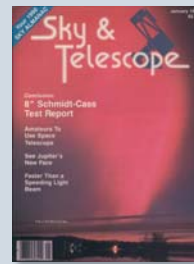

FALLING SNOW FALLING PRICES

With the holidays just around the corner, the coolest thing we could do is make it even easier to own an award-winning Sky-Watcher scope or mount.

So, from Nov. 15th to Dec. 31st we're offering some pretty frosty deals!

For complete details, go to skywatcherusa.com

NEW!
**Star Adventurer
Photo Package**

Lightweight and powerful, this mount is perfect for wide-angle terrestrial and astrophotography.

Only \$319

Shown with optional EQ base. Tripod, camera and ball-head adapter not included.



NEW!
**Star Adventurer
Astro Package**

The perfect grab-and-go tracking GoTo mount for globe-trotting astronomers.

Only \$339

Shown with optional EQ base and counterweight kit. Tripod and OTA not included.



Save up to \$150

on the top-performing ProED APO doublets. Perfect for visual and astrophotography!



Save 10% on the versatile Virtuoso mount. Create easy timelapse and panoramic videos and pics. **Only \$225!**



Save \$100 on the ProED 80/AllView mount combo. The ideal night and day, grab and go kit!



Save up to \$300

on an ultra-portable Sky-Watcher collapsible Dobsonian. Lots of light gathering in an easy-to-move package.

©2014 Sky-Watcher USA. Specifications subject to change without notice. 20-14024. From now until the day after Christmas, we're going to have it's A Wonderful Life on continuously here at Sky-Watcher USA. HD. We may throw in a viewing or two of Scrooged, but only because Carol Kane is the most awesome Christmas Ghost.

Sky-Watcher® USA
Be amazed.

For information on all of our products and services, or to find an authorized Sky-Watcher USA dealer near you, just visit www.skywatcherusa.com.

Don't forget to follow us on Facebook and Twitter!

SOLAR SYSTEM | Comet Siding Spring Skims Mars

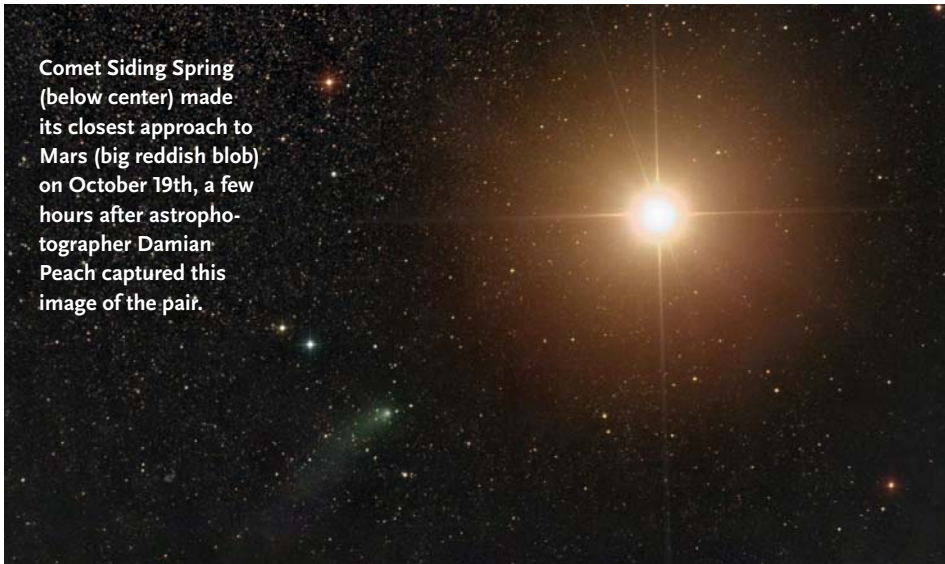

Comet Siding Spring (below center) made its closest approach to Mars (big reddish blob) on October 19th, a few hours after astrophotographer Damian Peach captured this image of the pair.

SEN / DAMIAN PEACH

History was made on October 19th, as a comet passed closer to a planet (without hitting it) than ever before in recorded memory. Unfortunately for backyard observers, that planet was Mars.

Comet Siding Spring (C/2013 A1) passed 137,000 km (85,000 miles) above the Red Planet's surface — about a third of the Earth-Moon distance. The dust tail in its wake missed Mars, but not by much.

This Oort Cloud comet is a first-time visitor to the inner solar system. When spotted in January 2013 by veteran comet-hunter Rob McNaught, C/2013 A1 was

still 7.2 astronomical units (1.1 billion km) from the Sun. By then its nucleus had already started releasing gas and dust to form a coma. Most comets don't "turn on" until they get much closer in.

Planetary scientists, excited by the prospect of studying a pristine relic from the solar system's formation, readied an armada of spacecraft and ground-based telescopes for the event. The most anticipated observations came from NASA's three orbiters: Mars Reconnaissance Orbiter, Mars Odyssey, and the Mars Atmosphere and Volatile Evolution

(MAVEN) spacecraft. Also on the scene were the European orbiter Mars Express and India's Mars Orbiter Mission (MOM), as well as the Opportunity and Curiosity rovers on the planet's surface.

As a precaution, engineers from NASA and the European Space Agency manipulated the trajectories of their respective orbiters to put the spacecraft all on the opposite side of the planet during the window of greatest danger. Initial results confirm these craft weathered the event unharmed by debris.

Comet Siding Spring passed through its orbit's perihelion just 5½ days after zipping past Mars, so activity was expected to be very high during its pass. However, observers noted a fall-off in the comet's brightness as the encounter neared. Preliminary images from MRO's HiRISE camera also suggest that the comet's icy nucleus is only half as large as the 700 meters (0.4 mile) scientists had estimated.

Meanwhile, MAVEN and MOM were both watching for changes in the composition and temperature of the planet's upper atmosphere as the comet's extended gas-and-dust coma briefly enveloped the planet. Scientists are working to disentangle the effects from the coronal mass ejection that passed Mars around the same time.

■ J. KELLY BEATTY

IN BRIEF

Citizen Scientists Probe Early Galaxies.

New data collected by Galaxy Zoo volunteers show galaxies form barred structures much earlier in cosmic history than previously thought. Previous observations have shown that the fraction of barred galaxies dropped from 50–70% in the nearby universe to 10% when the universe was only 6 billion years old. But as Brooke Simmons (Oxford, U.K.) and colleagues report in an upcoming *Monthly Notices of the Royal Astronomical Society*, extending the data back to when the universe

was only 3 billion years old shows that the number of barred galaxies was still as high as 10%, and not the expected zero. These early barred galaxies might have formed either because their contents settled down earlier than thought would happen, or because they were formed by two galaxies colliding.

■ SHANNON HALL

Neutrino Detection Confirms Sun's

Power Source. Deep inside the Sun pairs of protons fuse to form deuterium nuclei, kick-starting nuclear fusion. Although the complex "proton-proton" chain is now standard theory,

the solar neutrinos produced in the chain's first step have eluded detection for decades. Now, researchers using the Borexino detector — a tub of liquid designed to emit light when neutrinos interact with the liquid's electrons — have captured the elusive neutrinos. The results, published in the August 28th *Nature*, confirm that 99% of the Sun's power comes from the proton-proton fusion process and demonstrate the intricate interplay between theory and observation. Although the particles' existence was not in question, it's an incredible feat to detect them.

■ SHANNON HALL

The KAF-50100 has 3X more resolution than the KAF-16803



The KAF-50100 has 1/3 more area than the KAF-16803

NGC 5367 imaged with ProLine PL16803. Image courtesy of Wolfgang Pramper.

The New Standard for High Resolution: 50 Megapixels



The gray box above is the actual size of the KAF-50100 imaging area. Compare to the KAF-16803 (black box) and KAI-11002 (blue box).

KAF-50100:
8136 x 6132
6 micron pixels

The world's first KAF-50100 sensor with microlenses is the result of a year-long collaborative effort between ON Semiconductor (formerly Truesense, formerly Kodak) and Finger Lakes Instrumentation. Our goal: to create a sensor with both high resolution and excellent quantum efficiency (QE). The significantly boosted QE of the new KAF-50100 sensor brings it in line with popular sensors such as the KAF-16803 and KAI-11002 but with much higher spatial resolution. Initial tests indicate that the microlensed KAF-50100 has more than double the quantum efficiency of the original sensor.

At Finger Lakes Instrumentation, we design and build unrivaled cameras, filter wheels, and focusers to pave your way to success—whichever path you choose. Designed and manufactured in New York, USA.

Visit us at
www.flicamera.com
for more information
about our cooled CCD
cameras, focusers, and
color filter wheels.



LUNAR | Geologically Recent Volcanism on the Moon

Images from NASA's Lunar Reconnaissance Orbiter show 70 small, curious features that might be from volcanic eruptions in the past 50 to 100 million years, Sarah Braden (Arizona State University) and colleagues report October 12th in *Nature Geoscience*.

The suspect locations are what geologists term *irregular mare patches*, or IMPs. These distinctive rock deposits, up to 5 kilometers long, can be either rough, blocky outcrops or smooth patches with uniform texture. Both types exhibit very few impact craters, even down to the 0.5-meter resolution of the narrow-angle camera on NASA's Lunar Reconnaissance Orbiter. The lack of craters suggests that the features are relatively young.

The best known IMP, named Ina (or Ina D), was spotted in images taken by the crew of Apollo 15 in 1971. Even back then, lunar geologists had a hunch that Ina was a collapsed vent topping a low, broad shield volcano. But Ina's age has been uncertain.

Now, thanks to LRO's keen resolution, that site and many others appear to be

quite young. The IMPs' spectral characteristics suggest relatively fresh surfaces that have not been darkened by eons of exposure to space radiation. The smooth deposits are also the same thickness as other lunar basalt flows and haven't had their steep edges worn down, as older features have. Curiously, all the IMPs are on the Moon's nearside hemisphere, although statistically a few should have been spotted on the farside.

So, rather than a complete shutdown of lunar volcanism at least a billion years ago, as had been widely assumed, the process was apparently much more drawn out. Pockets of molten rock must have remained in the lunar mantle until very recently — and might still be there now. These findings have implications for how warm the lunar interior still is (and the true extent of its partially molten core). They also might suggest that heat flow measurements taken during the Apollo 15 and 17 missions were not anomalously high after all, as many have thought.

■ J. KELLY BEATTY

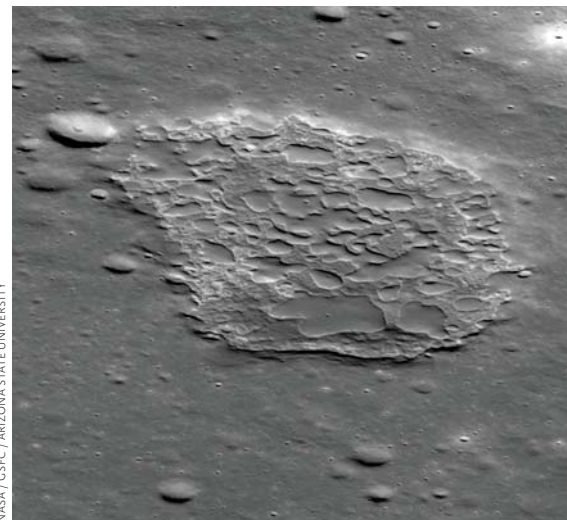

NASA / GSFC / ARIZONA STATE UNIVERSITY

Shown in this oblique view from NASA's Lunar Reconnaissance Orbiter, the feature Ina (big mottled region) might be from a recent volcanic eruption on the Moon. The shallow depression is about 50 meters deep. Illumination is from the bottom; the smooth patches are convex and lie above the rough surface. (If the smooth patches look like holes to you, imagine pressing your thumb into Ina's depression — it can help reset your perspective of the edges.)

IN BRIEF

Work Begins on Thirty Meter Telescope.

Officials gathered on October 7th for the dedication and groundbreaking of the Thirty Meter Telescope (TMT), slated for completion in 2022. TMT will combine 492 individual hexagonal reflectors, each 1.4 meters across, in a honeycomb primary mirror with an effective diameter of 30 meters. The primary promises to provide 144 times more collecting area and 10 times better spatial resolution than the Hubble Space Telescope. Ceremonies were interrupted for several hours by a peaceful protest from native Hawaiians who oppose additional telescopes on the sacred summit of Mauna Kea. (See page 60 for more on hurdles faced by big scopes.)

■ J. KELLY BEATTY

Gamma-ray Novae Explained? Astronomers might have an explanation for why classical novae emit gamma rays (*S&T*: Nov. 2014, p. 14).

Laura Chomiuk (Michigan State University) and colleagues used several radio arrays to observe the nova V959 Monocerotis, starting about two weeks after the gamma-ray discovery and spread over several months. The observations revealed synchrotron radiation, which is created by relativistic particles and suggests the presence of shock fronts. What probably happened is, when the white dwarf went nova, it first spewed out thick, warm gas in a spherical shell around itself and its companion. As the gas flowed past the other star, the interaction forced the gas into a dense belt instead of a sphere. When the white dwarf later blew out a fast wind, the thick stuff funneled that wind out along the poles. Shocks formed at the boundaries between the slower, thick outflow and the faster, thin outflow. These shocks accelerated the particles responsible for the gamma rays and the synchrotron emission, the team reports October 8th in *Nature*.

■ CAMILLE M. CARLISLE

Small Galaxy Boasts Big Black Hole.

Astronomers have detected a supermassive black hole in the center of the ultracompact dwarf galaxy M60-UCD1 — where it has no right to be. Ultracompact dwarf galaxies are similar in size to globular clusters but at least 10 times more massive. Scientists have debated whether they are unusually massive star clusters or the remnants of larger galaxies that have been stripped down to their cores. But dwarf galaxies normally don't have supermassive black holes, and M60-UCD1's black hole is 21 million times the mass of the Sun, about 5 times more massive than the Milky Way's black hole. The mass suggests the original galaxy had a central bulge roughly 100 times more massive than M60-UCD1's total stellar mass, Anil Seth (University of Utah) and colleagues report September 18th in *Nature*. The detection is the first observational evidence for the stripped-down theory.

■ EMILY CONOVER



ORION®

Since 1975

EVERYTHING FOR THE AMATEUR ASTRONOMER



FREE SHIPPING on orders of \$250 or more — **INSTALLMENT BILLING** on orders of \$350 or more
See website for details.

Gobble up light with its 5.0" lens

Orion® StarSeeker™ III 127mm GoTo Mak-Cass
#10069 \$599.99



Deluxe upgrade of our popular XT8 Classic

Orion® SkyQuest™ XT8 PLUS Dobsonian
#8974 \$499.99

WE ALSO SUGGEST



Orion® 1.25" 13% Transmission Moon Filter
#5662 \$19.99



Orion® Padded Telescope Case
#15174 \$89.99



Orion® MoonMap 260
#51919 \$12.99



Orion® Observer™ 70mm Equatorial Refractor
#9882 \$169.99



Orion® StarShoot™ AutoGuider Pro Mono Camera
#52031 \$379.99



Orion® GoScope™ II 70mm Travel Telescope Moon Kit
#10034 \$79.99



Orion® StarMax™ 90mm TableTop Maksutov-Cassegrain
#10022 \$199.99



Orion® Atlas™ EQ-G Computerized GoTo Mount
#24338 \$1,499.99



Orion® SpaceProbe™ 130ST Equatorial Reflector
#9007 \$299.99



Orion® Shorty™ 1.25" 2x Barlow Lens
#8711 \$46.99



Orion® SkyScanner™ 100mm TableTop Reflector
#10012 \$119.99



Orion® StarBlast™ 90mm Altazimuth Travel Refractor
#10029 \$219.99



Orion® Planetary Observing Guide Kit
#25703 \$49.99



Orion® Awesome AutoGuider Refractor Telescope Package
#24770 \$399.99



FunScope 76mm TableTop Reflector Telescope Moon Kit
#10033 \$64.99



Orion® StarShoot™ G3 Deep Space Color Imaging Camera
#53082 \$399.99

Retail prices shown are current as of 10/22/14 from Orion. Prices are subject to change without notice. Please check OrionTelescopes.com for the most current pricing. Dealer pricing and/or promotions may vary.

OrionTelescopes.com

Shop Orion On-the-Go. Easy Access right on your Smartphone.



Shopping has never been easier. To learn more about Orion products and see a larger assortment, please check out the digital eCatalogs on our website!

BLACK HOLES | No Big Beast for Two ULXs

Two studies suggest that some of the ultraluminous X-ray sources (ULXs) thought to be beefy black holes are created by much less massive objects.

ULXs spew out X-rays at luminosities roughly a trillion times the Sun's X-ray luminosity. The standard explanation for a ULX is that the X-rays come from extremely hot material that a black hole has pulled from a companion star. The more massive the black hole, the brighter its accretion disk can be.

But ULXs are uncomfortably bright: to explain them, a stellar-mass black hole would need to reach or surpass its maximum gas-gobbling rate, called the Eddington limit. That might be possible due to "force-feeding" that can occur under certain conditions. Or these sources might be intermediate-mass black holes (IMBHs), theoretical objects with masses of hundreds to thousands of Suns that would fill the no-man's land between stellar-mass and supermassive black holes.

Among ULXs, the sources M82 X-1 and ESO 243-49 HLX-1 are the two best IMBH candidates; evidence suggesting that M82 X-1 is a 400 solar-mass black hole

appeared in the September 4th *Nature*.

Now, a pair of papers published on October 9th in *Nature* demonstrate that two other ULXs are *not* IMBHs.

Christian Motch (University of Strasbourg, France) and colleagues observed variations in a ULX's emission in the spiral galaxy NGC 7793. The measurements pegged the orbital period of the black hole and its companion to 64 days and constrained the black hole's mass to be less than 15 solar masses. This means that the black hole gobbles up matter at twice its Eddington limit, confirming the force-feeding picture.

The more surprising result comes from Matteo Bachetti (University of Toulouse, France) and colleagues, who detected pulsations from another ULX in the galaxy M82, proving it's not a black hole at all, but a pulsar. Astronomers hadn't expected pulsars to be ULXs, because to do so pulsars would have to exceed their Eddington limits to an extreme degree. In this case, the pulsar surpasses its Eddington limit by a factor of 100 — an unprecedented amount, difficult to reconcile with theory.

■ EMILY CONOVER

GALAXIES | Mergers Create Disk Galaxies

Observations from several radio telescopes confirm that, when two galaxies merge, their progeny often have extended gaseous disks.

Simulations from the 1970s suggested that, when two big disk-shaped galaxies merged, they'd create a big elliptical, a fairly featureless spheroid of stars. But about a decade ago, better simulations by several teams showed that, if the disk galaxies have a lot of gas, the object their merger creates will also be a disk galaxy, with spiral arms or maybe even a central bar.

Junko Ueda (National Astronomical Observatory of Japan) and colleagues have now confirmed this prediction with observations, published in the September *Astrophysical Journal Supplement*. The team looked at emission from cold molecular gas from 37 merger-created galaxies, using both new and archival data. Of the 37 galaxies, the team easily detected gas in 30, and 24 showed signs of disk rotation.

Of the 24, 11 (46%) have big gas disks, meaning they are on their way to forming either spiral or lenticular galaxies. The disks of the remaining 13 are smaller than their stellar bulges; those galaxies will become ellipticals.

■ CAMILLE M. CARLISLE

Watch a video of how the collisions and observations work at skypub.com/diskmergers.

GALACTIC CENTER | G2 Survives Pass

This past spring, the world's astronomers watched a mysterious, gaseous object called G2 slingshot around the Milky Way's supermassive black hole (*S&T*: June 2013, p. 22). Astronomers first spotted G2 in 2011, and its crazy orbit immediately sparked debate: G2 makes a beeline for the black hole, whips around it, and shoots straight back out again. To do so, the object must have somehow lost enough angular momentum that, instead of following a more circular orbit, it started to fall headlong toward the black hole, Sagittarius A*.

The answer to the mystery is twisted up in G2's nature: is it merely a gas cloud, or does it hide a star inside?

The hope was that G2 would reveal its nature during its close encounter with Sgr A* in March 2014. However, the data are still inconclusive. The issue is that the two

teams that spearhead the infrared observations of our galactic downtown depend on different types of data.

The Max Planck Institute team has fabulous measurements from the SINFONI spectrograph at Paranal Observatory in Chile. These data show an extended gas tail disrupted during the close pass. On the other hand, the UCLA team has exquisite images from the Keck Observatory on Mauna Kea. The images for spring and summer 2014 show an unresolved compact object that didn't brighten and stuck to its orbit during the pass, as you'd expect for a dust-enshrouded star.

The discrepancy might exist because the two types of observations are looking at different features: the spectra catch gas that's stretched out from the orbit, while the images catch the dusty shell heated

by the star within. The MPI observations thus wouldn't rule out a star; they would just show that gas was yanked out during the close pass.

As G2 moves farther from Sgr A*, the view will become clearer. And if Sgr A* slowly brightens in the next few years, it'll indicate that it did indeed tear gas off G2 and that this gas fell through the accretion flow toward the black hole. That could reveal G2's nature and how much stuff it lost during the pass.

A completely different probe is also in place: the star S2, which at closest approach whizzes closer to the black hole than G2 did. S2 will reach pericenter around 2018, and the effect it has (or doesn't have) on the hot gas surrounding the black hole could reveal much about the environment and, potentially, why G2 behaved the way it did during its pass. ♦

■ CAMILLE M. CARLISLE

Only the Best for Santa's Bag

OPT's elves are waiting to help you, too

Nice List

Apogee, ASA, Astro-Physics, Astrodon,
AstroTrac, Atik, Baader, Canon,
Celestron, Coronado, Explore Scientific,
FLI, iOptron, JMI, Kendrick,
Losmandy, Lunt, Meade, Nikon,
Officina Stellare, Orion, PlaneWave,
QSI, SBIG, Software Bisque,
Starlight Xpress, Stellarvue,
Takahashi, Tele Vue, TPO, Vixen
ZWO...and lots more!

The logo for OPT (Optical Products Technology) features the letters 'OPT' in a bold, white, sans-serif font. The letters are set against a white, curved swoosh that starts under the 'O' and extends to the right, ending under the 'T'. The entire logo is positioned on a red background at the bottom left of the advertisement.

OPT

OPTtelescopes.com | 800.483.6287



The Big Payback

We're causing a mass extinction now. Can we prevent the next one?



© CAN STOCK PHOTO INC. / FREEZING PICTURE

YOU'VE HEARD HOW humanity is currently causing a new mass extinction rivaling, in rate and numbers of species lost, the other five such events that have occurred since the Cambrian explosion 530 million years ago filled our planet with complex life.

But we're not the first kind of life to radically change the environment. For example, 2.5 billion years ago, cyanobacteria began flooding Earth's atmosphere with poisonous oxygen. The rise of oxygen triggered extinctions and a climate catastrophe, destroying a methane greenhouse and plunging Earth into a global deep-freeze. All because cyanobacteria figured out how to exploit solar energy — using photosynthesis to grow and releasing oxygen as a byproduct.

Today we humans see ourselves behaving in a similar way, and it seems deeply irresponsible. In theory, we, unlike microbes, have awareness of our actions and thus bear responsibility for them. But do we have awareness or control of ourselves as global actors? Sometimes it seems as though on a planetary scale we are watching ourselves from afar, unable to control our actions, as in a nightmare when you can't stop yourself from doing something bad.

Yet I think we are awakening. The world is being knitted together electronically. Slowly we are developing more of a global view of ourselves and of the need to act collectively with some sense of intentionality and responsibility. This does not require any higher moral sense, only an enlightened sense of self-interest and self-preservation.

We may be in for a rough century, but hopefully we'll get through it with an eventually stabilized population and by developing a new global energy system that does

not wreck the natural systems upon which we depend. Then it may be time for payback. What can humanity do for Earth that would possibly help atone for the damage we are now doing?

We could build a planetary defense system. Sooner or later another huge asteroid or comet will be on course to strike Earth, but as long as our descendants are on the case, our biosphere never need suffer another mass-extinction-causing impact. Maybe this could be some kind of long-term compensation to the biosphere.

We could potentially intervene against harmful climate swings, even perhaps prevent future ice ages. Another ice age would be much more extreme than the climate changes we are facing now. We don't want to try to live through that, and, if we get our act together, we'll never have to. And we would save a lot of other species in the process.

If we last that long then we will have become a new kind of entity on the planet: self-aware world-changers with the sense to work with the planet, not against it. In the distant future, our successors may even be able to help defeat another threat to the biosphere: the eventual runaway greenhouse that will envelop Earth as the Sun heats up in its later years. Given billions of years of engineering prowess, we may be able to solve this problem and help Earth's biosphere outlive the Sun. Someday we may be the best thing to ever have happened to life on Earth.

But first we need to get through this century. ♦

David Grinspoon is an astrobiologist and author at the Library of Congress. Follow his escapades on Twitter at @DrFunkySpoon.



The Horsehead Nebula in Orion (IC 434) courtesy of R. Jay GaBany (www.cosmotography.com)

This image was produced with a RCOS half meter telescope, an Apogee Alta U16M camera and Astrodon E-Series filters. Exposure times: 720 minutes Luminance, 270 minutes Red, 270 minutes Green, 270 minutes Blue and 420 minutes h-alpha (all 1X1).

Apogee has been manufacturing and supplying cooled CCD cameras to astronomers around the world since it was founded in 1993.

Apogee's Alta camera series is designed to offer a broad range of sensor options attractive to the Astronomy community. The new Aspen and Ascent cameras further extends the Apogee portfolio providing higher performance and better affordability.

In 2013 Apogee was acquired by Andor Technology, adding further expertise in camera development, manufacturing and customer support.

Apogee
IMAGING SYSTEMS

www.ccd.com

ANDOR
an Oxford Instruments company

■ Deep Fields

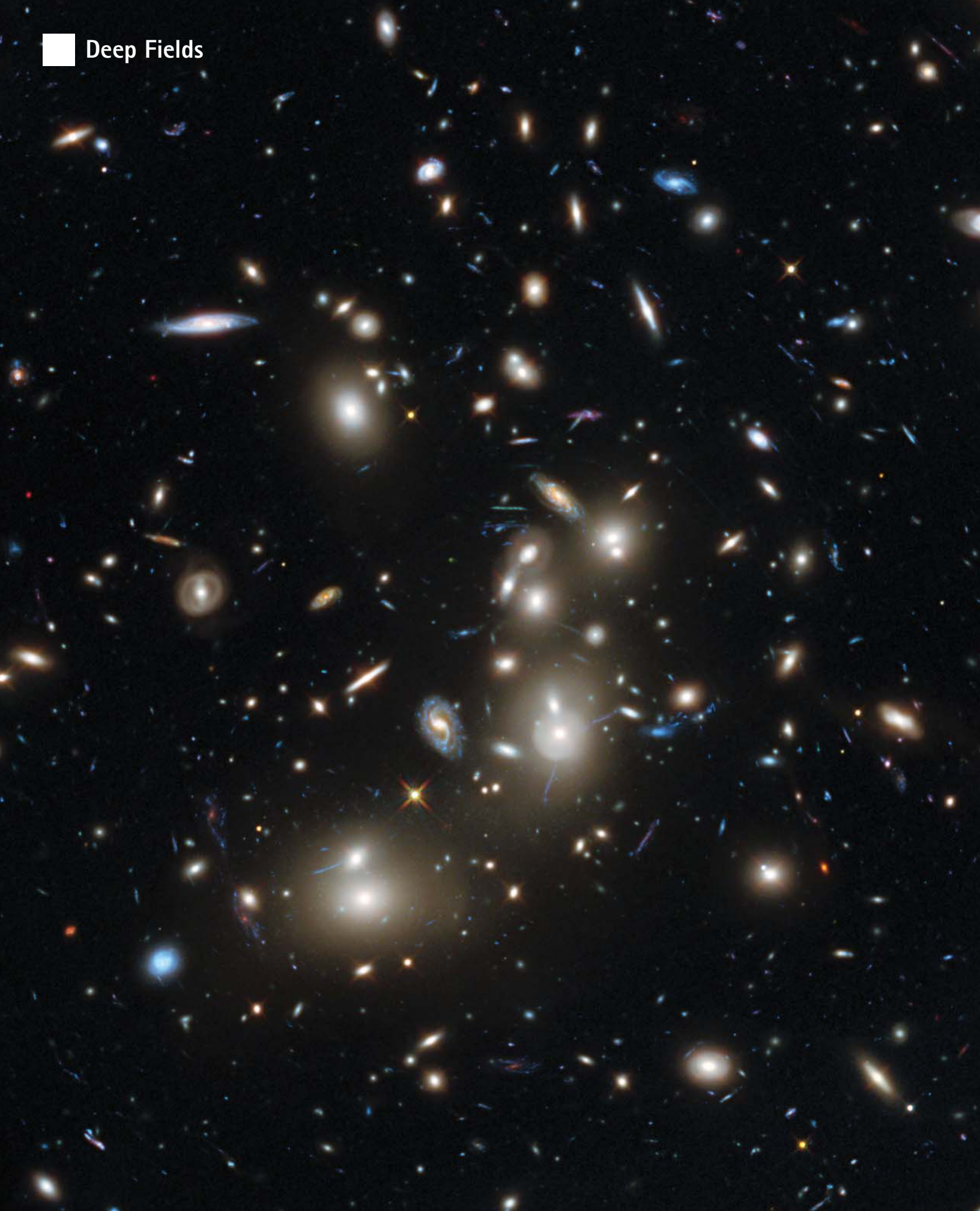

Hubble Goes the Distance



Govert Schilling

Using nature's gravitational lenses, astronomers are pushing the Space Telescope to its very limits to reveal primordial galaxies.

The Hubble Space Telescope, which will celebrate its 25th anniversary in April 2015, is the symbol of our era for every astronomer. Orbiting above the distorting effects of Earth's atmosphere, it has provided unprecedented views of star clusters, nebulae, and galaxies. Using its suite of sensitive cameras and detectors, and focusing on "blank" patches of sky, Hubble has also revealed the building blocks of galaxies so far away that their light took many billions of years to reach us.

But cosmologists want to reach even farther. And since they can't swap Hubble's 2.4-meter mirror for a larger one, they're now seeking assistance from nature's own zoom lenses. Using the gravitational-lensing effects of six remote clusters of galaxies, the new Frontier Fields program aims to push back Hubble's limits and study the true dawn of galaxy formation. "We're going deeper than ever before," says principal investigator Jennifer Lotz of the Space Telescope Science Institute (STScI).

Last March, at a conference in Rome, Lotz presented the first results of the new program. Her showpiece is a November 2013 Wide Field Camera 3 (WFC3) image of Abell 2744, nicknamed Pandora's Cluster. But a second cluster, MACS J0416.1-2403, has also been observed by Hubble's Advanced Camera for Surveys (ACS). In the summer of 2014, WFC3 was aimed at MACS J0416,

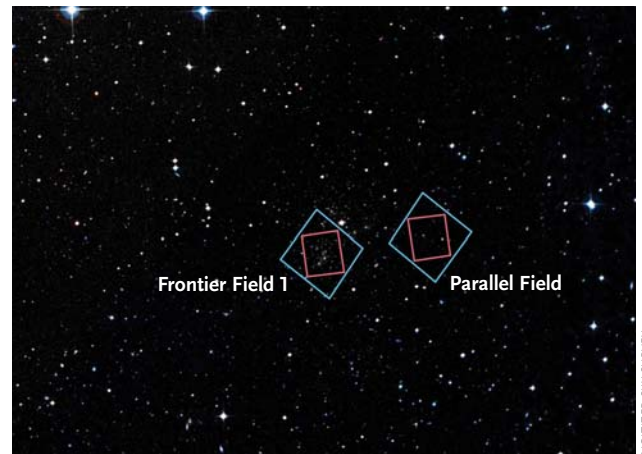

DIGITIZED SKY SURVEY

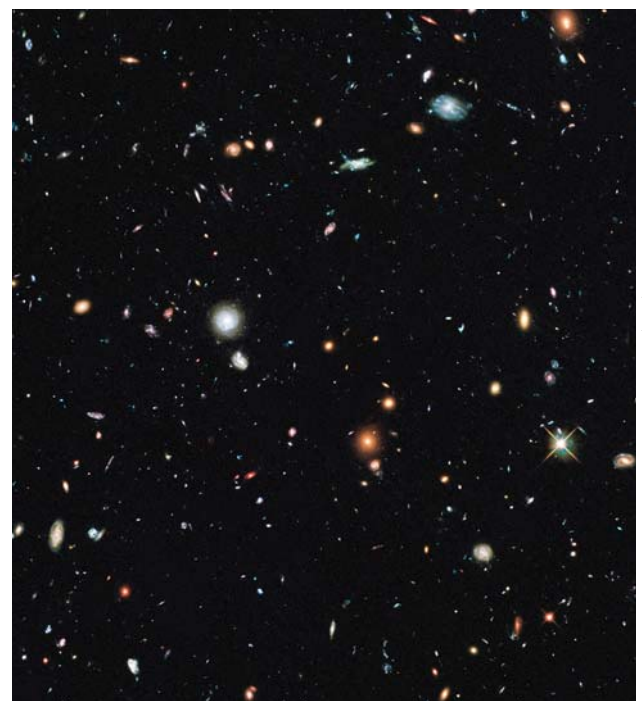

NASA / ESA / J. LOTZ / M. MOUNTAIN / A. KOEKEMOER / HFF TEAM (STScI)

FRONTIER FIELD 1 *Left:* The gravity of the giant galaxy cluster Abell 2744 (Pandora's Cluster) is distorting and magnifying the images of small, faint background galaxies.

PARALLEL FIELD *Right:* When astronomers first aimed Hubble's Wide Field Camera 3 at Abell 2744 to take Frontier Field 1, the Advanced Camera for Surveys was pointed nearby to image a parallel field. Later, the roles were reversed so that both fields could be imaged at three optical and four near-infrared wavelengths. Scientists use the parallel field as a basis for comparison. *Above right:* The ACS camera field is blue; the WFC3 field is red.

NASA / ESA / J. LOTZ / M. MOUNTAIN / A. KOEKEMOER / HFF TEAM (STScI)

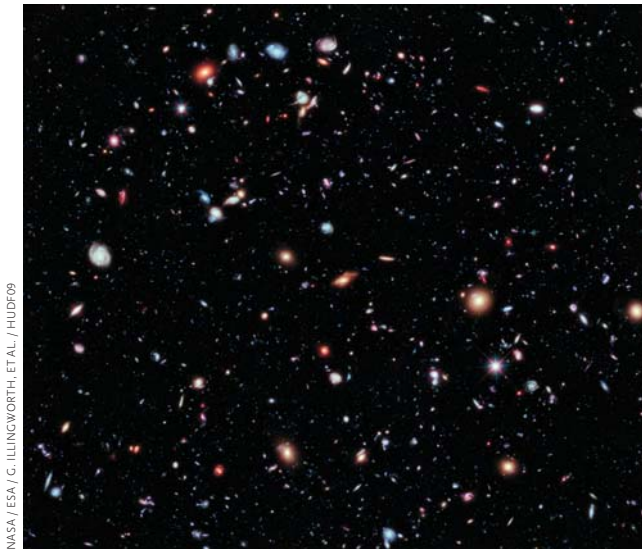

while ACS observed Abell 2744. In 2015 Lotz's team will target two other clusters with both cameras, and in 2016 the program is scheduled to conclude with observations of a fifth and sixth cluster. A whopping 140 orbits worth of precious Hubble observing time will be devoted to each of the six fields.

By studying remote galaxies that are gravitationally magnified and brightened by the foreground clusters' gravity, Lotz and her colleagues can study objects that are intrinsically fainter than would otherwise be possible to see. The team expects to obtain a more representative view of the galaxy population in the newborn universe.

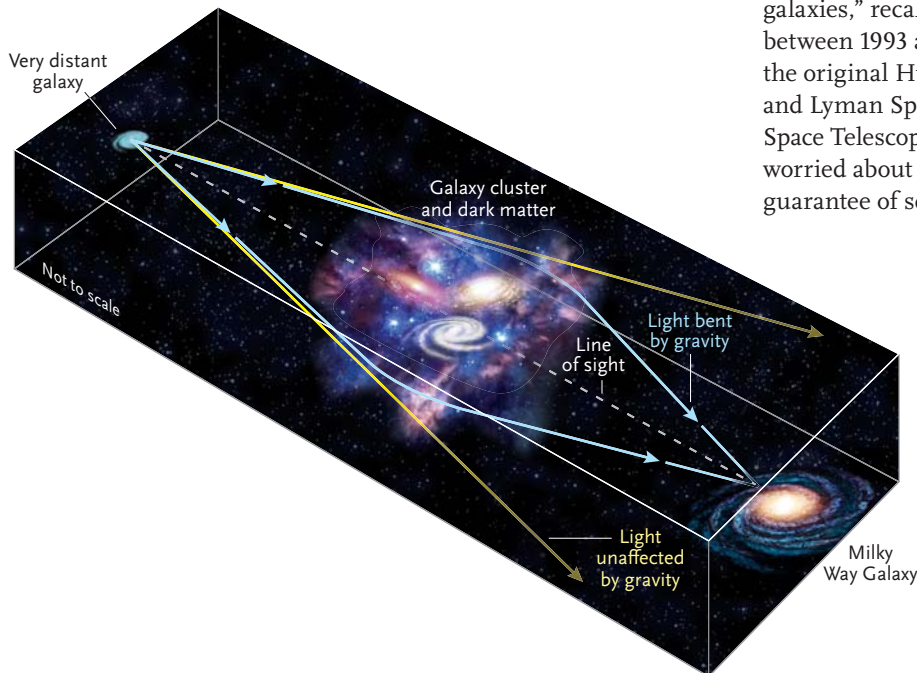

EXTREME DEEP FIELD Astronomers assembled the eXtreme Deep Field (XDF) by combining a decade of Hubble images of a tiny, 2-by-2.3 arcminute patch of the southern constellation Fornax. It contains about 5,500 galaxies at various distances, mostly small blue early ones. The data come from the Advanced Camera for Surveys and Wide Field Camera 3. The XDF is the deepest image yet taken, and reveals galaxies that existed as early as 500 million years after the Big Bang.

“We want to carry out a statistical study of the early formation history of galaxies,” says Lotz. “When did the lights in the universe come on? How many galaxies were formed within the first few hundred million years? Was the formation of the first galaxies a very gradual process, or did it happen more suddenly? To answer these questions, we need to go 10 times deeper than before.”

NASA's Spitzer Space Telescope and Chandra X-ray Observatory, as well as large ground-based telescopes, are making supporting observations of the Frontier Fields. In the Abell 2744 data, one group found that the number of galaxies drops significantly beyond a redshift of 8.5 or so (corresponding to a cosmic age of 600 million years). And two groups each recently found a galaxy at a redshift of 9.8, corresponding to a time only 490 million years after the Big Bang.

Pretty Picture to Treasure Trove

Twenty-five years ago, few could imagine that long-exposure observations of “empty” fields would yield exciting new results. “In a 1990 *Science* publication, Princeton astrophysicist John Bahcall wrote that he did not expect such deep observations to reveal a new population of galaxies,” recalls Bob Williams, who directed the STScI between 1993 and 1998. “In 1995, when we embarked on the original Hubble Deep Field program, both Bahcall and Lyman Spitzer, one of the fathers of the Hubble Space Telescope, were strongly opposed to the idea. They worried about the public response, since there was no guarantee of scientific success.”

GRAVITATIONAL LENSING The Frontier Fields program takes advantage of gravitational lensing, an effect predicted by Einstein's general theory of relativity that astronomers have already observed in a variety of contexts. Thanks to relativity, the gravity of a massive foreground object (in this case, a galaxy cluster) serves as a lens — redirecting toward Earth some of a background object's light that would otherwise miss us. Gravitational lensing thus magnifies the background object (though distorting it), enabling telescopes to detect distant galaxies that would otherwise fall below the detectability threshold.

S&T: LEAH TISCIONE

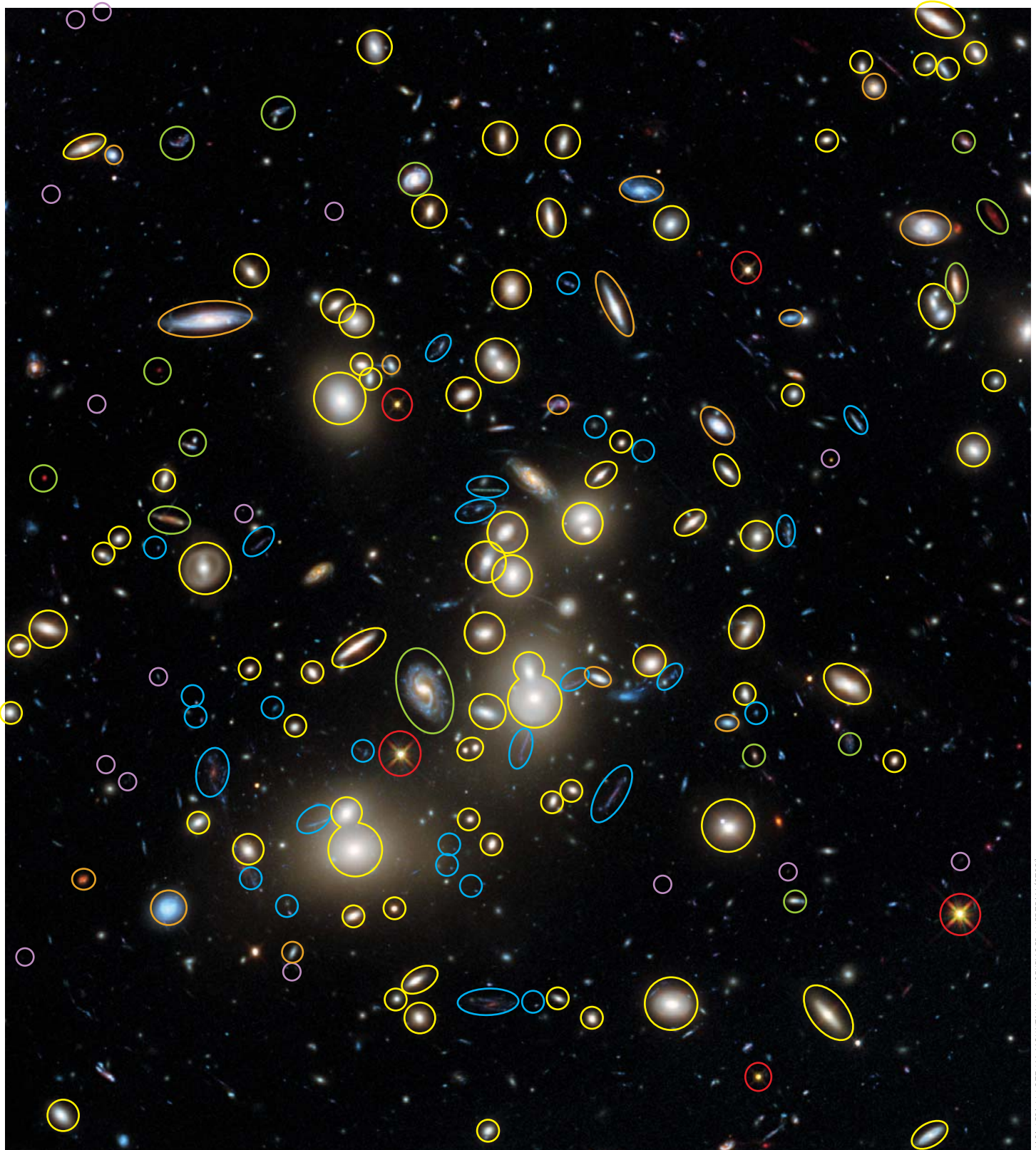

NASA / ESA / J. LOTZ / M. MOUNTAIN / A. KOEKEMOER / HFF TEAM (STSC)

- Foreground stars
- Foreground galaxies
- Weakly lensed galaxies
- Strongly lensed galaxies
- Extremely distant galaxies
- Cluster galaxies

TUNNEL THROUGH TIME All the Hubble deep fields are 3-dimensional tunnels through time, capturing objects from relatively nearby Milky Way stars to primeval galaxies whose light has taken 13 billion years to reach us. The labels identify different types of objects appearing in Frontier Field 1.

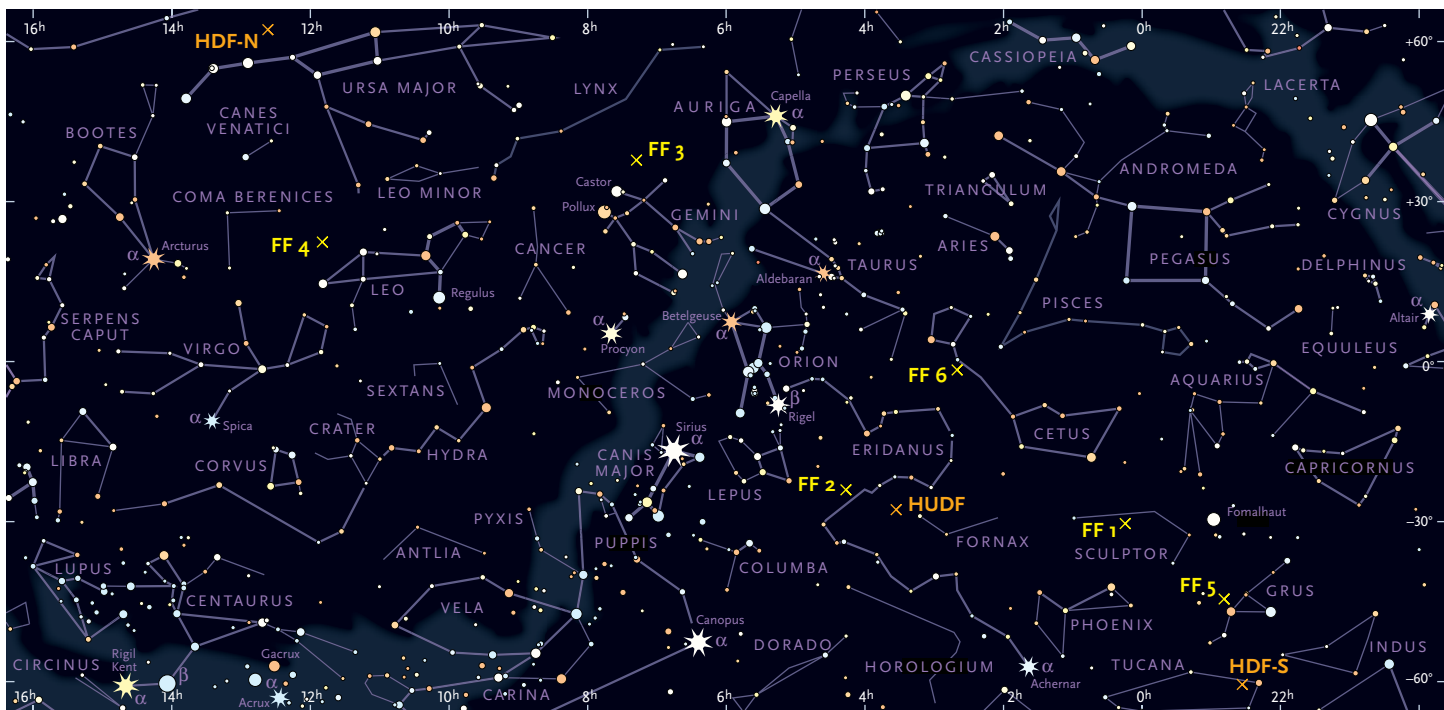

SOURCE: HFF TEAM (STSC)

THE SIX FIELDS The Frontier Fields Team targeted six patches of sky for their program. Unlike previous Hubble deep fields, which were selected for being relatively empty regions, the Frontier Fields all have foreground galaxy clusters that act as gravitational lenses.

Back then, Hubble’s public image was indeed something to worry about. The primary mirror’s spherical aberration had just been corrected — 3½ years after launch — and many people (and politicians!) saw Hubble as a costly, underperforming astronomy toy. Why would anyone devote 150 orbits worth of observing time to study an empty region of the sky? But Williams knew better. Recent long-exposure Hubble images taken by Mark Dickinson (now at the National Optical Astronomy Observatory) had shown misshapen “train-wreck” galaxies at a redshift of 1.2, corresponding to a look-back time of two-thirds of the age of the universe. “This to me was transformational,” says Williams.

At a morning coffee meeting in the Institute’s library,

Williams and his colleagues first brainstormed the idea of a Hubble Deep Field. “We were really excited. Everything was up for discussion,” he recalls. “Should we do one field or many? Should it be targeted at known objects or should it be blank? Which filters would be the best to use? When would the data be released to the astronomical community and to the public?” An outside advisory committee failed to reach a consensus, and in the end, Williams decided to spend a huge chunk of his director’s discretionary observing time — a total of 141 hours — on observations of a small, relatively empty patch of Ursa Major. “It had to be done,” he recalls, “so we did it.”

Hubble’s Wide Field and Planetary Camera 2 (WFPC2) obtained the 342 separate exposures (in four wavelength

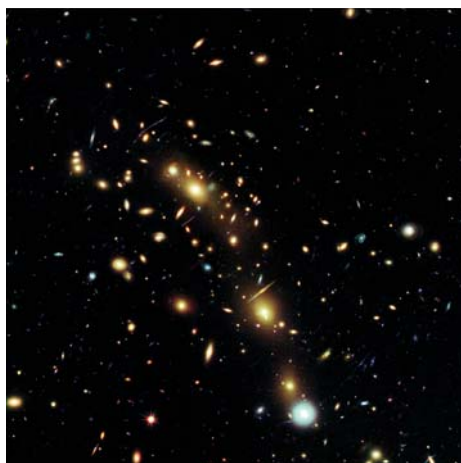

bands) between December 18 and 28, 1995, and a mere 17 days later, the fully reduced data set was made public. The iconic image revealed more than 2,000 individual galaxies, most of them at very large distances. “In retrospect, it was a huge success,” says Williams, “especially when spectra of 130 remote galaxies were taken over the subsequent three years by the Keck telescope. Keck turned the Hubble Deep Field from a pretty picture into a scientific treasure trove.”

Deeper and Deeper

A galaxy’s spectrum yields its redshift, and the redshift reveals how long the galaxy’s light has been traveling through expanding space. In other words, spectra turn deep-field images into 3-dimensional core samples of the early universe. Unfortunately, spectra can be obtained only for relatively bright objects, so the distances of the faintest galaxies in the Hubble Deep Field remained unknown. That is, until Chuck Steidel (Caltech), Piero Madau (University of California, Santa Cruz), and others perfected the photometric redshift technique, in which a galaxy’s redshift can be estimated from its relative brightness in various passbands.

This 1960s technique was originally quite inaccurate. But by developing better model spectra and comparing the results with the Keck spectra of Hubble Deep Field galaxies, astronomers significantly increased the precision. In fact, the technique has been extended to 30 or more passbands. “It’s almost like obtaining a low-resolution spectrum,” says Williams. “To me, the validation of the concept of photometric redshift is the single most important result that emerged from the Hubble Deep Field and its successors.”

Indeed, the new Frontier Fields program is far from the first campaign to follow in the footsteps of the original Hubble Deep Field. In September and October 1998, WFPC2 imaged the Deep Field South, in Tucana, which was simultaneously observed by the Space Telescope Imaging Spectrograph (STIS) and the Near Infrared Camera and Multi-Object Spectrometer (NICMOS). Next came

the Hubble Ultra-Deep Field (2003-04), with its infrared extension in 2012, and the Hubble eXtreme Deep Field (2012). Meanwhile, projects such as GOODS and CANDELS (*S&T*: June 2014, p. 18) provided astronomers with somewhat shallower data over wider fields of view. And of course, the various Hubble Deep Fields have also been studied in detail by space telescopes such as Chandra and Spitzer to obtain X-ray and mid-infrared images.

“These are marvelous programs yielding fascinating results,” says Williams. For example, the deep-field programs have shown that half a billion years after the Big Bang, the universe’s star-formation rate was quite low, but then it ramped up several orders of magnitude until it reached a peak when the universe was some 2.5 billion years old. They also indicated that there must have been large numbers of hot but low-luminosity objects in the early universe — probably enough to explain the reionization of intergalactic matter at a time when the universe was less than a billion years old.

And, of course, they have revealed the most distant galaxies known, including the current record holders, MACS0647-JD and UDFj-39546284, which are probably both at a redshift of 10 or 11. According to Williams, “Our current knowledge of the distant universe is largely based on the succession of deep fields. They have shown us the early history of cosmic processes that have ultimately led to the origin of humanity. Understanding these processes will make humanity much more comprehensible to all of us.”

The Deepest Views

So how can astronomers improve on what Hubble has done so far? In the summer of 2012, current STScI director Matt Mountain found himself discussing the prospects for yet another deep-field campaign with Hubble Mission Head Ken Sembach. After consulting a Hubble science working group and various experts within the community, the concept of the Frontier Fields program emerged — a name that was coined by Sembach. “The question was: Can we do better than the Hubble Ultra-



COMING SOON

These images show the other five planned Frontier Fields. All feature massive galaxy clusters whose gravitational lensing will reveal extremely faint galaxies in the early universe.

NASA / ESA / J. LOTZ /
M. MOUNTAIN / A. KOEKEMOER
/ HFF TEAM (STSCI)

NASA / ESA / A. ZITRIN (CALIF. INST. OF TECHNOLOGY) AND J. LOTZ, M. MOUNTAIN, A. KOEHOER, AND THE HFF TEAM (STSC)

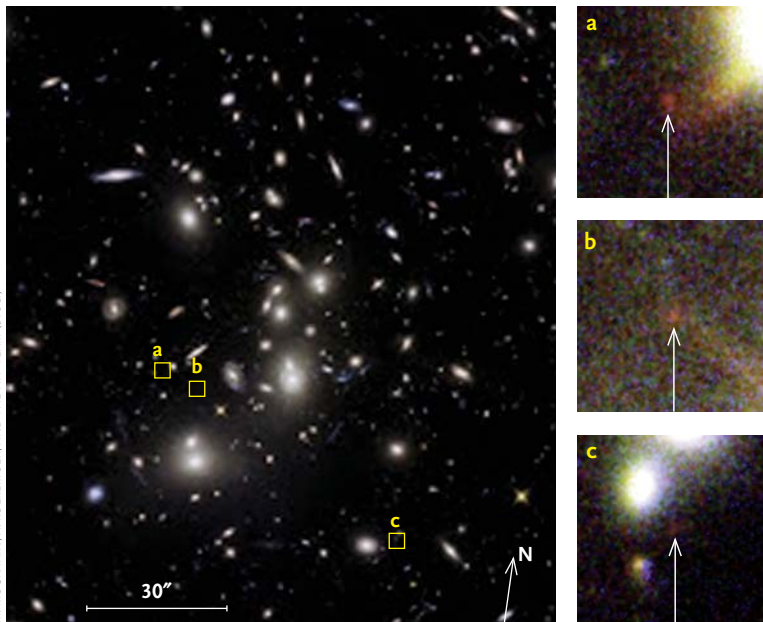

PRIMORDIAL GALAXY Astronomers found this small, extremely distant galaxy in Frontier Field 1. Based on its brightness at different wavelengths, this galaxy, triply lensed above, appears to have a redshift of 9.8, making it one of the most distant objects ever seen. Its existence proves that small galaxies were assembling when the universe was only 490 million years old.

Deep Field?” says Lotz. “The answer was: yes, if we use Hubble in tandem with one of nature’s own telescopes, and repeat the feat six times.”

Using gravitational lenses will give astronomers “a sneak peek at the JWST universe,” says Lotz, referring to Hubble’s infrared successor, the 6.5-meter James Webb Space Telescope, scheduled to launch in late 2018. During each observing run, one of Hubble’s main cameras (ACS and WFC3) will be trained at a carefully selected cluster of galaxies, while the other camera will observe a neighboring blank field. Half a year later, the fields will be swapped, so each cluster and each blank field will be imaged at three optical wavelengths with ACS and at four infrared wavelengths with WFC3.

Observations of the blank parallel fields are necessary because astronomers are concerned about *cosmic variance*. “On average, the universe looks the same everywhere, but not *exactly* the same,” explains Lotz. “The Ultra-Deep Field was just one pointing, so we will now add six other blank-field pointings as a control sample.” But the earliest and most distant galaxies are expected to be found in the cluster fields, where gravitational lensing might magnify their feeble radiation by tenfold or — in very rare cases — even a hundredfold. “Ours won’t be the deepest *images*,” says Lotz, “but they will provide by far the deepest *view*.”

The six clusters have been selected on the basis of the expected magnification they have to offer, on their apparent dimensions on the sky (they have to fit within the field of view of Hubble’s cameras), and on their locations: both the Keck telescope in Hawaii and the submillimeter

ALMA Observatory in Chile will be used for follow-up observations. Five independent groups have produced magnification maps of the clusters on the basis of existing observations, to carefully predict where lensed images of extremely faint background galaxies might show up.

In three years, Lotz’s team hopes to complete observations of all six Frontier Fields. By then, the project will have devoted a total of 840 orbits worth of Hubble observing time. At press time, only observations of the first four of the six fields have been approved; a committee will soon review the program and decide on whether or not to continue with the final two fields. Lotz is quite confident: “We may even add more fields in the future,” she says. “Hubble’s successor, the James Webb Space Telescope, may target these clusters in the future as well as better clusters that were not known when we selected the Frontier Fields.”

Scientific analysis of the first Frontier Fields observations is already in full swing. In a November 1st *Astrophysical Journal* paper, Wei Zheng (Johns Hopkins University) and his colleagues report the detection of 18 galaxies beyond a redshift (z) of 7 in the Abell 2744 data, but none at a redshift of about 9 or higher. But they caution that more Frontier Fields’ data will be needed before a definitive claim can be made regarding a rapid buildup of galaxies by redshift 8.

But other groups found a triply lensed galaxy at a redshift of 9.8. This object is a mere 300 light-years across, making it 500 times smaller than our Milky Way. It’s basically a small clump of matter that’s just starting to churn out stars at a rate about one-third that of our galaxy, and also at a slower rate than the redshift-8 galaxies. The object was first discovered by a team led by Adi Zitrin (Caltech), which published its results in the September 5 online edition of *The Astrophysical Journal Letters*. It was confirmed independently by a team led by Pascal Oesch (Yale University); the results have been submitted to *The Astrophysical Journal*. The discovery might represent the tip of the iceberg of a large population of small galaxies that later merged to form the behemoths we see today.

The Frontier Fields program is really the best Hubble can do with deep-field observations. The quarter-century-old space telescope won’t be equipped with any new cameras or detectors, and by teaming it up with nature’s own telescopes, astronomers are pushing Hubble to its very limits. Bob Williams, the father of the original Hubble Deep Field, is impressed: “It’s great stuff. In some other disciplines, scientists can study remains from the past. But astronomy is the only science that really lets you *witness* the past.” ♦

Contributing editor **Govert Schilling** is author of the new book *Deep Space*. He won the American Astronomical Society’s prestigious David N. Schramm Award for Science Journalism for “*The Frozen Neutrino Catcher*” (*S&T*: Jan. 2014, p. 18.)

CORONADO®

THE ULTIMATE IN SOLAR OBSERVATION



Personal Solar Telescope (PST)
Shown Double Stacked
Shown on optional DSM GOTO mount
Prices starting at \$699



SolarMaxII 90
Shown Double Stacked
Prices starting at \$3,599

SolarMaxII 60
Shown Double Stacked
Prices starting at \$1,299

THE SUN ALWAYS RISES

Unless you live at our extreme northern or southern latitudes, you can count on this daily occurrence and, unless it is cloudy, you can also count on observing our closest star, the Sun. The Sun's weather is always changing; calm one moment, a frenetic mass of turbulence the next. Don't miss an opportunity to witness this through a **Coronado SolarMax™ II** telescope.

Only the Meade's Coronado SolarMaxII has the exclusive, patented, RichView™ system that delivers quick and easy tuning for highest contrast, yielding detailed views of active regions, flairs, filaments and other surface features or, just as quickly, retune for prominences on the solar limb. With apertures of 90mm, 60mm and 40mm there is a Coronado solar telescope that will meet everyone's needs. Meade has you covered.

OPT Telescopes
800.483.6287
www.optcorp.com

B & H Photo
800.482.8143
www.bhphotovideo.com

Telescopes.com
800.303.5873
www.telescopes.com

Woodland Hills
888.427.8766
www.telescopes.net

Adorama
800.223.2500
www.adorama.com

Optics Planet
800.504.5897
www.opticsplanet.com

High Point Scientific
800.266.9590
www.highpointscientific.com

Astronomics
800.422.7876
www.astronomics.com

Canada • Khan Scopes
800.580.7160
www.khanscope.com

 **MEADE** INSTRUMENTS

www.meade.com



Hot Products

By the Editors of *Sky & Telescope*

Each year, S&T editors scour the marketplace searching for what we consider to be some of the year's most exciting new products. To make our list, a product must not only be new but should introduce new technologies or processes, provide a solution to an old problem, or simply deliver exceptional value. Our Hot Products list for 2015 includes a variety of gadgets ranging from a mobile astronomy app to filters, cameras, mounts, and, of course, telescopes. This year prices range from a free Apple planetarium app to an astrograph priced at over \$15,000. We hope you enjoy reading about these innovative products that piqued our interest in late 2014.

► **THE HDX110 EQ-G
GOTO EQUATORIAL MOUNT**

Orion Telescopes & Binoculars
www.telescope.com

The budget-minded amateur looking to step up to a high-capacity mount should take a closer look at Orion's new flagship Go To mount. Billed as an observatory-class German equatorial mount, the HDX110 can handle payloads of up to 110 pounds (not including counterweights), which translates to a mount that can keep up with anyone having a case of "aperture fever." Its innovative use of closed-loop Go To electronics allows the mount to retain pointing accuracy even when manually slewed, making this a tough package to beat.

U.S. price: \$4,999.99





◀ AO-X ACTIVE OPTICS

Santa Barbara Instrument Group • www.sbig.com

SBIG brings high-speed corrections to its flagship STX and STXL CCD cameras with its AO-X unit. The ultra-compact design minimizes back-focus requirements. Its generous 3-inch optical element used to rapidly tip-and-tilt the optical path ensures your stars are round and sharp across the largest CCD detectors.

U.S. price: \$2,195

▶ NEXSTAR EVOLUTION

Celestron • www.celestron.com

Continuing its long tradition of innovative improvements to the fork-mounted Schmidt-Cassegrain telescope (SCT), Celestron's new NexStar Evolution series is loaded with extremely well-thought-out features for the beginning or experienced amateur. First and foremost is its built-in wireless network, which allows users to control the telescope pointing using their own smartphone or tablet running Celestron's *SkyPortal* mobile app. Additionally, each of the 6-, 8-, and 9.25-inch Evolution telescopes includes a built-in rechargeable battery that frees observers from the tether of needing an electrical outlet or cumbersome power supply.

U.S. price: from \$1,199.95



◀ DAYSTAR QUARK H α FILTER

Daystar Filters
daystarfilters.com

How many of us have thought about owning a solar hydrogen-alpha filter without the bother of custom adapters? Daystar Filters' Quark H α filter fits the bill by combining an electronically controlled, temperature-regulated etalon and 4.2 \times telecentric Barlow into a safe, lightweight unit that's placed directly into your small refractor's focuser. Simply plug in the power and you'll be enjoying stunning views of prominences, filaments, and other solar features. See our in-depth review in the November 2014 issue, page 38.

U.S. price: \$995





▲ **WO-STAR 71 ASTROGRAPH**

William Optics • www.williamoptics.com

William Optics unleashes the WO-Star 71, a small astrograph built with the travelling astrophotographer in mind. This compact 5-element 71-mm (2.79-inch) f/4.9 apochromatic refractor provides a 45mm imaging circle designed to cover the popular mid-sized detectors on the market today. Designed specifically for astrophotography, its 2½-inch focuser terminates in a 48mm thread and includes a wide-aperture Canon EOS T-ring adapter. **U.S. price: \$998**

▼ **FULL-FRAME FILTERS**

Astronomik • www.astronomik.com

Astronomik keeps up with the growing popularity of full-frame DSLRs for astrophotography by expanding its series of clip-in imaging filters for Canon cameras. The EOS XL-Clip Filters for Canon EOS 5D and 6D cameras come in a variety of passbands to meet your imaging needs whether you've modified your camera or not.

U.S. price: from \$129.95

► **VIP-3010 BIG PARACORR**

Tele Vue • www.televue.com

Newtonian reflectors continue to be a popular (and relatively inexpensive) gateway into the world of large-aperture observing and imaging. But all large, fast Newtonians suffer from coma, an optical aberration that makes stars appear as distorted seagulls away from the center of the field. Tele Vue's newest addition to its line of coma correctors tackles this issue for fast Newtonians with 3-inch focusers to provide coma-free star images across the widest fields for both visual and photographic use.

U.S. price: \$1,095



◀ **GOSKYWATCH PLANETARIUM**

GoSoftworks Development Co. • www.gosoftworks.com

This free planetarium app for Apple devices lets you quickly identify stars, planets, and constellations by simply holding your device up towards the sky. *GoSkyWatch* is most useful when showing a family member or guest an object in the night sky; simply point your device at a planet, say, and the app will announce what object you're looking at. There are no cumbersome buttons to push or modes to select — just you, your device, and the sky above. And it's certainly hard to complain about the price.

U.S. price: FREE



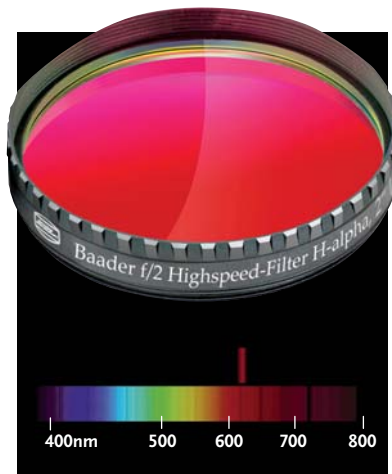

▶ **ML50100 CCD CAMERA**

Finger Lakes Instrumentation
www.flicamera.com

Finger Lakes Instrumentation becomes the first camera manufacturer out of the gate with the newest big-chip detector. This compact camera incorporates the sensitive KAF-50100 CCD detector with a whopping 50 megapixels, enabling users to capture vast, high-resolution vistas in one fell swoop. But be forewarned: a top-of-the-line astrograph will be required to take full advantage of the chip's huge 61.3-mm image circle.

U.S. price: \$15,495



▲ **HIGH-SPEED NARROWBAND FILTERS**

Baader Planetarium • www.baader-planetarium.com

Despite the blazing-fast photographic speed of exotic astrographs (see below), imagers using these instruments are at a disadvantage when photographing through narrowband filters. Light passing through a narrowband filter at a steep angle is significantly shifted, often outside of the target wavelength. Baader Planetarium solves this issue with its High-Speed Narrowband Filter series tuned specifically for use with these fast instruments, resulting in deep, high-contrast images.

U.S. price: from \$213



▼ **NTM CRESCENT BEARING**

New Moon Telescopes • www.newmoontelescopes.com

In the quest to build large-aperture, lightweight Dobsonian telescopes, one area often overlooked for weight-saving measures is the altitude bearings. New Moon Telescopes' innovative new design sheds pounds without sacrificing stability by incorporating an open-framework design. As an added bonus, its textured powder coating provides the perfect "stiction" for tracking at high magnifications.

U.S. price: from \$298



◀ **THE ROWE-ACKERMANN SCHMIDT CAMERA**

Celestron • www.celestron.com

At long last, Celestron rolls out the true successor to its legendary Schmidt camera series from the 1980s, and at an attractive price to boot. The 11-inch f/2.2 Rowe-Ackermann Schmidt Astrograph produces pinpoint stars across its sprawling 70mm image circle to take advantage of the largest detectors on the market today. It incorporates a host of convenient features, including a custom FeatherTouch Micro Focus knob and a built-in cooling fan. The telescope includes both T-thread and M48 adapters to attach your camera.

U.S. price: \$3,499.95



◀ **VARI-MAX PRO-SERIES VARIABLE EYEPIECE PROJECTION ADAPTER**

CNC Parts Supply • www.telescopeadapters.com

A few years ago, many amateurs may have thought the technique of eyepiece projection astrophotography (which uses an eyepiece to focus light onto your camera's detector) was going the way of film cameras. But the increasing quality of HD video modes incorporated into the latest DSLR cameras has caused a resurgence in this classic technique. CNC Parts Supply's VariMax Pro Series Variable Eyepiece Projection Adapter accepts some of the largest, high-quality eyepieces to help you take advantage of the latest wide-field, corrected eyepieces for your imaging needs.

U.S. price: \$129

▶ **IOPTRON CEM60**

iOptron • www.ioptron.com

Taking the center-balanced mount design to the next level, iOptron's CEM60 uses another novel approach to the issues of the equatorial drive and stability. By placing the mass of the mount closer to the middle of the equatorial head, the mount achieves greater stability and load capacity than other designs. In other words, this relatively small mount boasts an impressive weight rating of 60 lbs, not including the counterweights. Coupled with the mount's robust drives and GOTONOVA controller, this is a sturdy mount designed with the travelling astro-imager in mind.

U.S. price: \$2,499



◀ **HTN SERIES NEWTONIANS**

Hercules Telescopes • www.telescopeshercules.com

Newtonian reflectors aren't often thought of as versatile instruments. Their shallow back focus often limits their use to single applications. Hercules Telescopes aims to change that perception with its HTN series of Newtonian reflectors. Most intriguing is the series' 4-position indexed secondary mirror. This allows users to add visual accessories to one port, a camera on another, and effortlessly switch from imaging to visual use, making them perform like four telescopes in one. The HTN series also incorporates many weight-reducing features without sacrificing stability.

U.S. price: starting at \$9,950



◀ **IMAGING HARMER WYNNE ASTROGRAPH**

AG Optical Systems • www.agoptical.com

Another astrograph that piqued our interest this year, this large-aperture scope packs a fast f/3.9 focal ratio into a compact carbon-fiber truss design. The Imaging Harmer Wynne Astrograph incorporates a 3-element corrector that eliminates coma and astigmatism to achieve tight, round stars across its 52mm image circle. Additionally, the design provides a generous 8 inches of back focus, allowing users to include a wide variety of additional accessories within the optical path.

U.S. price: from \$15,775

▼ **STELLARVUE SVQ100 ASTROGRAPH**

Stellarvue • www.stellarvue.com

While many 4-inch refractors have made an appearance over the years, few are designed for photography from the get-go. That's why the Stellarvue SVQ100 Astrograph makes our list. This 100-mm apochromat incorporates a unique 4-element optical configuration with Ohara FPL53 glass to capture sharp, color-free stars across full-frame DSLR cameras and other large detectors. Other thoughtful features include an integrated 3-inch dual-speed Feather Touch focuser, sturdy tube rings, and both T-thread and 48mm adapters to attach your camera.

U.S. price: \$3,800



▲ **PIERRO-ASTRO ADC**

Pierro-Astro • www.pierro-astro.com

Planetary enthusiasts are well aware of our planet's atmosphere propensity to act as a prism while targeting the planets at low altitudes, splitting the target into an elongated smear of colors that robs the view of fine detail. Pierro-Astro's ADC (Atmospheric Dispersion Corrector) uses two adjustable prisms in a compact housing to counter this detrimental effect, resulting in fringe-free images of even the most challenging targets in our solar system.

Price: starting at 339 €



▶ **MAXIM DL 6**

Diffraction Limited • www.cyanogen.com

The popular CCD imaging program *MaxIm DL* gets a major upgrade in its newest edition. This time-tested software package now includes a host of new features to become the integrated solution for all your imaging needs. *MaxIm DL 6* not only controls your CCD camera and autoguider, it now incorporates *complete* observatory integration. Whether you're operating a single camera or a remote observatory, *MaxIm 6* now controls it all from your telescope to the building in which it resides, including autoguiding, weather monitoring, roof control, and remote switches, as well as a host of new image-processing features for producing accurate science.

U.S. price: starting at \$199

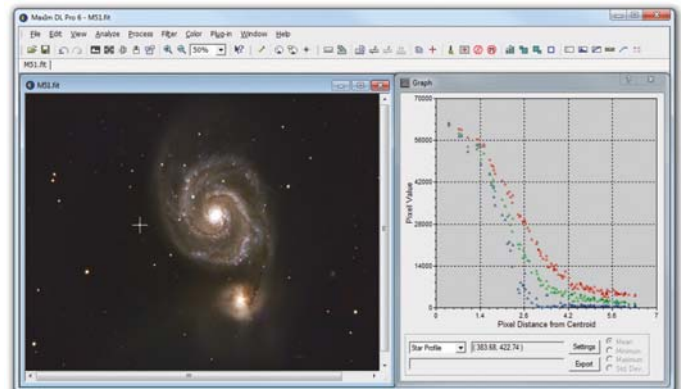



▲ **SKYGUIDER**
iOptron • www.ioptron.com

iOptron expands on its product line geared toward the “skyscape” astrophotographer with its new SkyGuider camera mount. Utilizing the same drive and gear used in the company’s capable iEQ25 German equatorial mount, the SkyGuider is designed to support a moderately hefty payload of cameras and lenses, and can also be configured with ball heads and cameras at both axes of the polar drive to double your photographic output.

U.S. price: starting at \$479

▶ **QHY INTERCAM IC8300**
QHYCCD • www.qhyccd.com

Many cameras have been built around the popular KAF8300 CCD detector, so it may come as a surprise to see another on this list. But none of them until now have made a camera with a built-in wireless router, allowing you to image without any cables tethering your computer to the camera. QHYCCD’s new InterCam IC8300 makes the arduous task of cord management a thing of the past.

U.S. price: starting at \$3,000

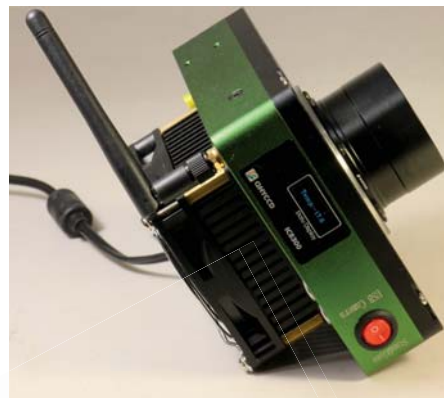

▲ **AFFORDABLE RITCHEY-CHRÉTIEN**

Astro-Tech
www.astronomics.com

As a company that’s built its reputation on high-quality instruments at an eye-catching price point, we weren’t really surprised when Astro-Tech announced its new line of truss-mounted Ritchey-Chrétien astrographs. What did surprise us was *how* affordable they are; even the largest, the AT16RCT, comes in at an attractive price of \$6,995. These astrographs incorporate advanced features not often found in such an affordable package, including cooling fans to aid in cooling the fused-quartz primary mirror, and multiple dovetail mounting plates. Considering that comparable models sold a decade ago for almost 5 times that, these are sure to turn heads.

U.S. price: \$6,995

◀ **PARAMOUNT MYT**
Software Bisque
www.bisque.com

Industry leader Software Bisque expands its selection of robotic telescope mounts to a wider audience with its newest and smallest offering, the Paramount MYT. Incorporating everything from its larger cousins and more, the MYT supports a load of up to 50 lbs., excluding counterweights, and comes complete with a copy of *The SkyX Professional Edition* with T-point and camera control add-ons for both PC and Apple platforms. And did we mention its low price?

U.S. price: \$6,000





▲ STAR ADVENTURER PHOTO PACKAGE

Sky-Watcher Telescopes
www.skywatcherusa.com

This compact camera drive caught our attention when we found out it not only will track your camera with the sky, but it also can control your camera and fire the shutter! The Sky-Watcher Star Adventurer Photo Package attaches to your tripod and can be accurately polar-aligned for long exposures. It also connects directly to your DSLR, acting as a programmable intervalometer to take time-lapse images and videos. The package also includes a ball-head tripod mount (not pictured above).

U.S. price: from \$319

► MERCURY GLOBE

Sky & Telescope
www.shopatsky.com

Crafted with a base map assembled from more than 18,000 images captured by NASA's Messenger spacecraft, the Mercury Globe is the first to portray the entire planet with true photographic detail. The names of more than 350 craters and other features are labeled, including craters named after famous artists, composers, and authors.

U.S. price: \$99.95



► EARTH GLOBE

Sky & Telescope
www.shopatsky.com

While countless globes of our home planet have been produced over the years, most are crisscrossed with lines and labels denoting political boundaries. The editors at *Sky & Telescope* present a photographic globe that depicts the Earth like the other rocky planets in our solar system. Major geographic features including continents, mountain ranges, and oceans are labeled, as well as some notable seafloor features. Based on NASA satellite imagery.

U.S. price: \$99.95



◀ LS50THA

Lunt Solar Systems
www.luntsolarsystems.com

Although there are other small solar hydrogen-alpha systems on the market, none come close to the quality and versatility of the Lunt Solar Systems LS50THa. The company updates its reliable package with the patented pressure tuner to allow users to view Doppler-shifted prominences. The system is upgradable with options for a larger back filter diagonal (which performs better for photography), and accepts a second front-mounted etalon (shown) to "double-stack" the system, further increasing visual contrast. ♦

U.S. price: starting at \$799

◀ INOVA PLM SERIES MULTI-PURPOSE CAMERAS

iNova • www.inovaccusa.com

While high-speed planetary video cameras have dominated the realm of planetary imaging over the past decade, rarely are these cameras suitable as a truly multi-purpose instrument. But that's just what caught our attention when we took a look at iNova's cameras. Its PLxCam series offers the respectable frame rate that planetary imagers desire, and accepts an optional cooling module to reduce noise in long exposures of deep-sky objects. Each model also functions as a capable autoguider.

U.S. price: starting at \$209





The dark Cone Nebula crowns the Christmas Tree open star cluster.

The Backyard Sky



Rod Mollise

Embrace the cold nights of winter to observe these seasonal delights.

Winter

Winter's here and I'm ready for it. By the time fall is over, I've had my fill of the clouds and haze that plague autumn on the U.S. Gulf Coast. Winter's passing cold fronts cleanse the sky and reduce the effects of light pollution, which is scattered and amplified by haze and humidity. There's always plenty to see from the backyard, but winter's clean, dry skies are naturally darker and better for deep-sky observing.

When you walk outside and look to the east on an early winter evening, the first constellation that catches your eye is mighty Orion. If you want to swing the telescope over to M42 for a quick look, be my guest. The Great Nebula is always a marvel, but tonight we're after less familiar quarry.

Let's begin our evening's journey in Monoceros, the Unicorn, Orion's neighboring constellation to the east. Despite an evocative name, the Unicorn is dim, with its most prominent star, Beta (β) Monocerotis, shining weakly in the backyard sky at magnitude 3.8. A computer-controlled Go To telescope will stand you in good stead when touring this constellation.

If there's a deep-sky object that spells "winter" for me other than the Orion Nebula, it's **NGC 2237**, the Rosette Nebula, an emission nebula shaped like a huge Christmas wreath that floats among the dim stars of Monoceros. I enjoyed this object for years from dark sites, but never tried to view it from my light-polluted backyard until a visiting amateur astronomer friend clued me in one cold night.

The Rosette is difficult, but it can be conquered with 8-inch and larger scopes if you remember the words "field" and "filter." The nebula is large, $80' \times 60'$, and you'll need to put some dark space around it to provide contrast. That will require an eyepiece capable of encompassing over a degree of sky. Unfortunately, using a low-magnification, wide-field eyepiece in light pollution will make the nebula harder to see rather than easier. Low power makes the background sky appear brighter. The cure is a nebula filter, which blocks most of the skyglow while allowing through the few specific wavelengths that many nebulae emit.

Following my friend's advice, I screwed an O III filter onto an eyepiece that yielded $1\frac{1}{2}^\circ$ of field in my 12-inch telescope, and had a look. The emission-line filter dimmed the stars but brought out the nebosity, first as disconnected patches, then as a big doughnut. The "doughnut hole" is occupied by a little dipper-shaped asterism, which is part of a larger open cluster, **NGC 2239**, involved with the nebula.

Our Monoceros holiday theme doesn't end with the Rosette's wreath; there's also a Christmas tree, **NGC 2264**, a lovely open cluster 5° northeast of our first stop. This big and bright star cluster shines at magnitude 4.1 and stretches across $40'$ of sky. Long-exposure images of the Christmas Tree Cluster don't do it justice, since they show hordes of background stars that obscure its shape.

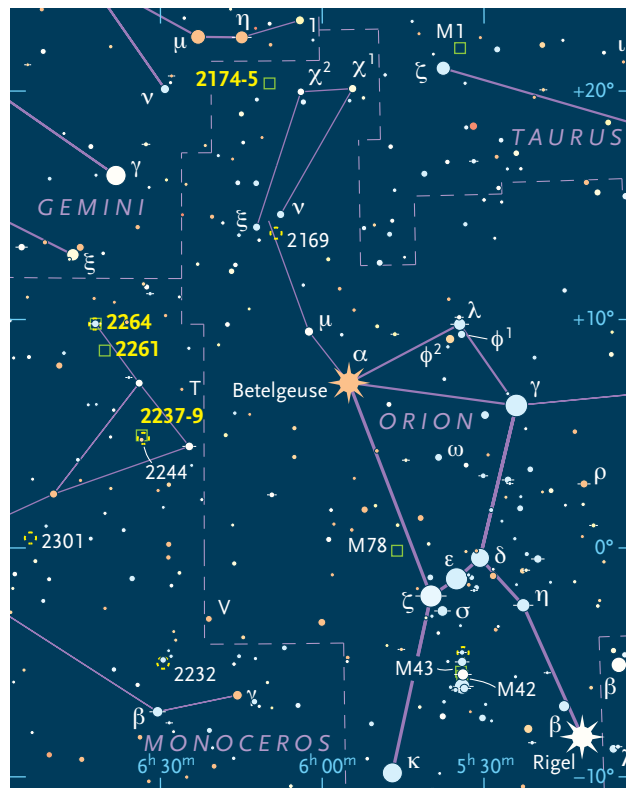

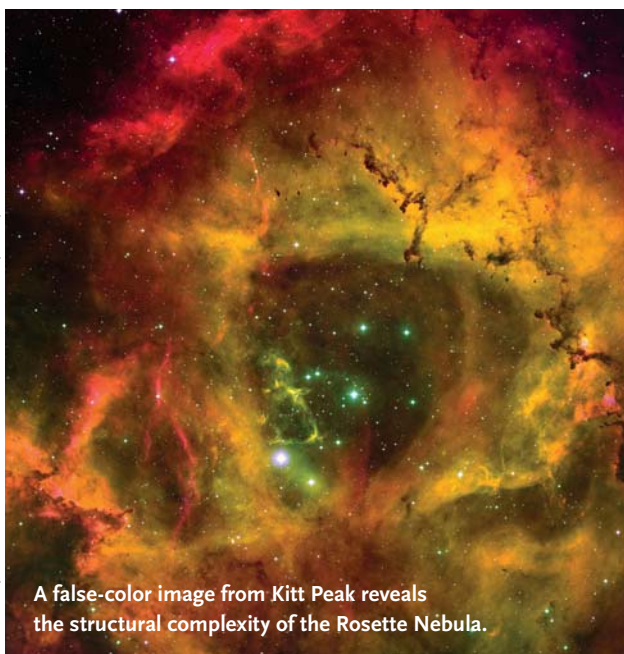

T. A. RECTOR / UNIVERSITY OF ALASKA ANCHORAGE, WYN AND NAO / AURA / NSF

A false-color image from Kitt Peak reveals the structural complexity of the Rosette Nebula.

In a low-power ocular, however, the triangular Yule tree, which extends about 20' from the variable star S Monocerotis at its "base," jumps right out. This Christmas tree even has a "star" at its top, the famous dark Cone Nebula, but that is a challenge for the largest scopes under the darkest skies.

Continuing in Monoceros, turn south for a degree to find a small, bright, and interesting nebula, **NGC 2261**, also called Hubble's Variable Nebula. At times, the little cloud appears slightly dimmer or brighter, and its shape will change between observing sessions. That's because R Monocerotis, an old, evolved star within the nebula, is blowing off its outer layers. The interaction between the material coming from the star and the dust already in the area creates shadows that cause the reflection nebosity to dim and brighten. NGC 2261's variable nature impelled the famous American astronomer Edwin Hubble to do the first in-depth study of it.

In a telescope at a magnification of 150×, Hubble's Variable Nebula is one of the best reflection nebulae in the sky. This type of object, which glows by the reflected light of nearby stars rather than by its own emissions, is often faint, but not NGC 2261. It's immediately obvious through the scope, looking remarkably like a small comet. R Monocerotis, shrouded in dust, forms the head, and the triangular 2.2' × 1.5' nebula extending from it makes the tail. Remarkably, it doesn't take a large telescope to see changes in the nebula. An 8-inch scope at high magnification is capable of detecting these variations. Dark streaks and patches can change shape over the course of just a few days.

I love winter's nebulae and star clusters, but as the season hits its midpoint, I find myself wanting galaxies.

Tips for Backyard Observers

You can't do anything about sky glow, but you can do something about ambient light. Light from nearby sources prevents your eyes from attaining as much dark adaptation as possible. Turn off any lights you can and shield your eyes. I drape a piece of dark cloth over my head when I'm at the eyepiece.

Many deep-sky observers use too little rather than too much magnification. Most objects are small to medium-sized targets, and magnifications of 100× and above will show more detail and spread out the background sky glow.

Wait for special nights. If you're after a particularly difficult object, look for it after a front passage when the sky is at its cleanest and driest.

Wait for special times. If you're having trouble with a target, allow it to culminate, or to rise as high in the sky as it ever will. You will then be looking at it through the thinnest layer of atmosphere possible.

Wait for calm nights. Good "seeing" — atmospheric steadiness — can be almost as important for faint galaxies as for planetary detail.

Nebula filters can reduce background sky glow and improve the contrast of emission and planetary nebulae. Unfortunately, they don't work on galaxies, star clusters, or reflection nebulae.

Keep trying. If you miss an object, keep after it night after night and you will often be rewarded.

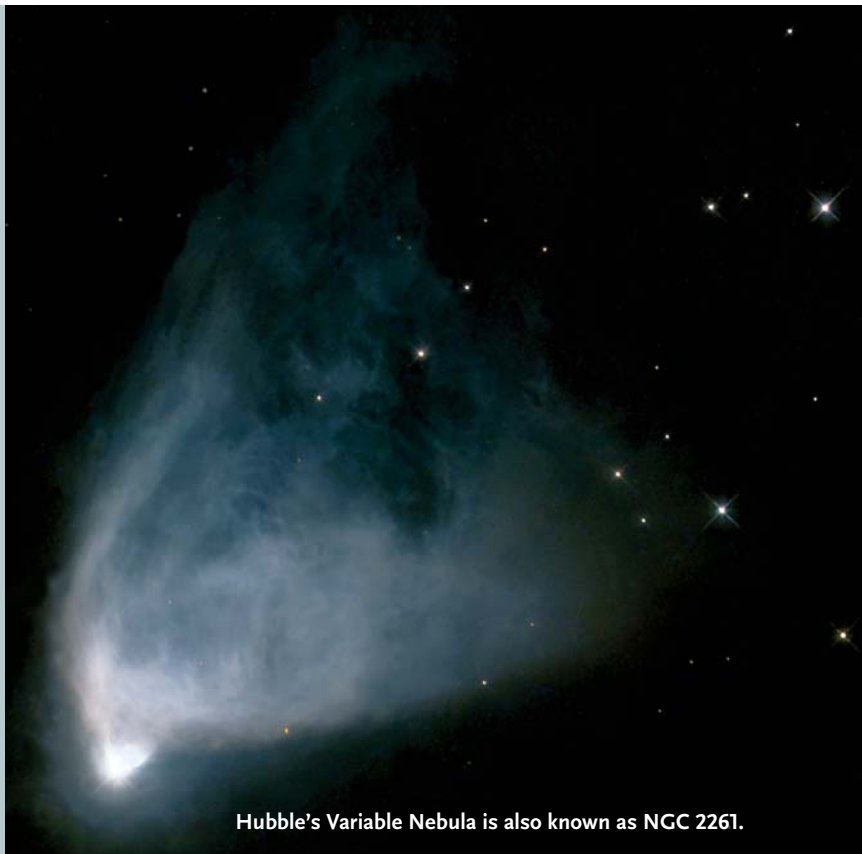

Hubble's Variable Nebula is also known as NGC 2261.

NASA / THE HUBBLE HERITAGE TEAM (AURA/STSCI)

Backyard Deep-Sky Treats for Winter

Object	Const	Type	Mag (v)	Size	RA	Dec
NGC 2237	Mon	Emission nebula	—	90' × 90'	6 ^h 30.9 ^m	+05° 03'
NGC 2239	Mon	Open cluster	—	24'	6 ^h 31.9 ^m	+04° 57'
NGC 2264	Mon	Open cluster	4.1	20'	6 ^h 41.0 ^m	+09° 54'
NGC 2261	Mon	Reflection nebula	—	2' × 1'	6 ^h 39.2 ^m	+08° 45'
NGC 1023	Per	Lenticular galaxy	9.5	8.7' × 3.0'	2 ^h 40.4 ^m	+39° 04'
NGC 2174/2175	Ori	Nebula with open cluster	—	40' × 30'	6 ^h 09.7 ^m	+20° 29'
NGC 2362	CMa	Open cluster	3.8	8'	7 ^h 18.7 ^m	-24° 57'
NGC 2359	CMa	Emission nebula	—	10' × 5'	7 ^h 18.5 ^m	-13° 14'
NGC 2354	CMa	Open cluster	6.5	20'	7 ^h 14.3 ^m	-25° 42'
NGC 1514	Tau	Planetary nebula	10.9	2.2' × 2.0'	4 ^h 09.3 ^m	+30° 47'

Winter, with the obscuring band of the Milky Way crossing the sky, isn't thought of as a good time for hunting galaxies. They are visible, however, including several in Perseus, which is beginning to sink in the west on January nights. The most prominent of these is **NGC 1023**, a member of our local galaxy supercluster.

Not only is this lenticular galaxy routinely visible in suburban skies, on a good night it can surprise. At magnitude 9.6, it's fairly bright for a galaxy, but its light is spread out over a relatively large area (7.6' × 2.8'), which dims it down a little. Under better conditions, NGC 1023's large lens-shaped disk may put in an appearance. On a poor night, all you may see is the galaxy's strongly elongated central region. I had no trouble spotting the galaxy with a 4-inch telescope from downtown Mobile, Alabama.

Now, let's move back southeast to mighty Orion. You're probably aware there are other nebulae in the constellation besides M42. The Hunter is near the Milky Way, in a star-forming region rich in gas clouds and star clusters. The constellation is home to several famous objects, including the notoriously dim Horsehead Nebula. Tonight, however, we're after a less well known target, one few amateurs seem to know about: **NGC 2174**, the Monkey Head Nebula.

This large 40' × 40' emission nebula is located away from Orion's body in the area of the upraised club in the northeastern part of the constellation. This probably explains why it isn't better known. It's also not an easy object. My best views of it from the suburbs have been through 10- to 12-inch telescopes equipped with nebula filters. At first, all you'll probably see is the sparse open cluster **NGC 2175** embedded in the nebula. Keep looking, however, and you may begin to make out a faint haze around the cluster's stars. In my 12-inch Newtonian telescope, "Old Betsy," the nebula extends for 20', so use a

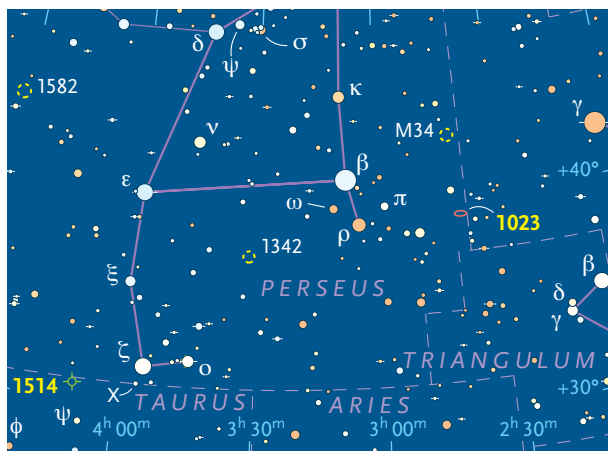

The bright star Tau Canis Majoris resides smack dab in the middle of the open star cluster NGC 2362.

wide-field eyepiece. Why “Monkey Head”? In images, the nebula looks a *little* like the head of a simian.

Let’s continue our tour with Canis Major, the Big Dog trotting along at Orion’s heels. **NGC 2362** is a bright and attractive 4.1-magnitude open star cluster spanning a mere 6’ × 6’. Depending on your scope and skies, you’ll see as many as 30 stars in this small area. That’s not the main attraction, however; that’s the bright 4.4-magnitude star Tau Canis Majoris near the center of the cluster.

Tau makes NGC 2362 an easy find, and also provides an amazing “special effect.” Stare at Tau and tap on the telescope’s tube. Naturally, the stars will jiggle, but Tau will seem to move *in a pattern different from the other stars*, undoubtedly due to the contrast between it and the dimmer cluster stars. This weird effect gives Tau its nickname, “The Jumping Spider Star.”

NGC 2359, Thor’s Helmet, Canis Major’s premier nebula, has a reputation for being tough. That was true before nebula filters came to amateur astronomy, but this 9’ × 9’ cloud, like many other formerly challenging nebulae, can now be seen from the backyard. In a filter-equipped 8-inch telescope, all I can detect is the oval body of the nebula, the helmet. With 12 inches of aperture, however, I can begin to see how the nebula got its name. There are two faint streamers of nebulosity extending to the west, the horns of Thor’s helmet.

Surprisingly, some deep-sky objects look better in the backyard than under country skies. From dark sites, **NGC 2354**, a 6.5-magnitude, 18’ × 18’ open cluster that lies 11° south of Sirius, is fairly rich but nothing special. From a



ESO / DIGITIZED SKY SURVEY 2 / DAVIDE DE MARTIN

This wide-field view highlights the nebulous “horns” of Thor’s Helmet (NGC 2359).

poorer location, however, it’s startling. With the dimmer stars gone, at 115× I see a 9.0-magnitude star surrounded by a ring of medium-bright suns. This ring, about 4’ in diameter, is so perfect as to look artificial.

We’ll move northeast to the celestial Bull to complete our backyard odyssey. The winter sky is full of planetary nebulae, but once you leave the Messier list, most are small or dim, or both. There are exceptions, however, including Taurus’s **NGC 1514**, the Crystal Ball Nebula. This 10th-magnitude, 2.8’-diameter gas ball is a marvel in a medium-power eyepiece equipped with an O III filter. The Crystal Ball’s 9.4-magnitude central star is easy to see; it’s surrounded by tenuous but obvious nebulosity. In large telescopes the nebula is elongated, but in my 12-inch it just looks round.

The night is old and my bones are cold. There’s always the temptation to observe “just one more object” on particularly good nights, but I’ve learned when to say when, to stop when I am still feeling good and wanting more. The beauties of the deep sky will be there waiting for me tomorrow, or next month, or next year over a lifetime of backyard nights. ♦

Contributing editor *Rod Mollise* keeps an astronomy blog at uncle-rods.blogspot.com and is author of several books, including *The Urban Astronomer’s Guide*.

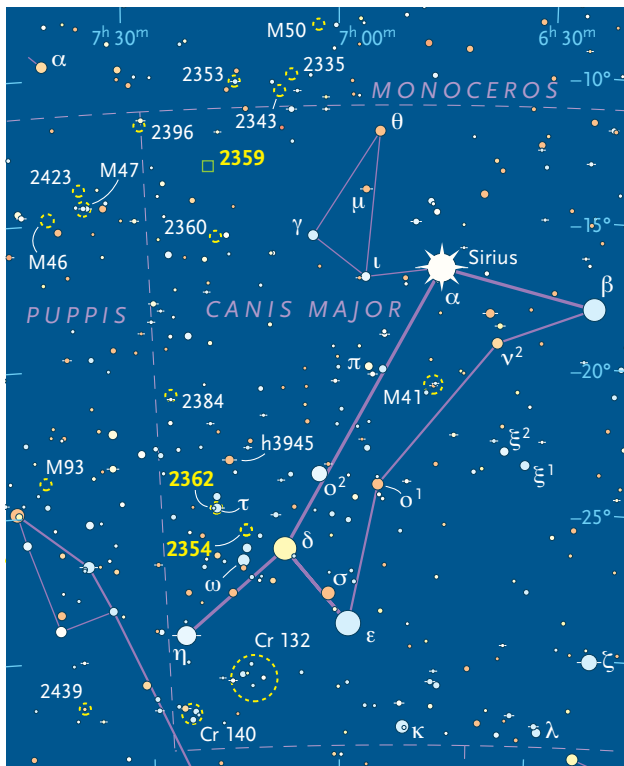



Smithsonian®

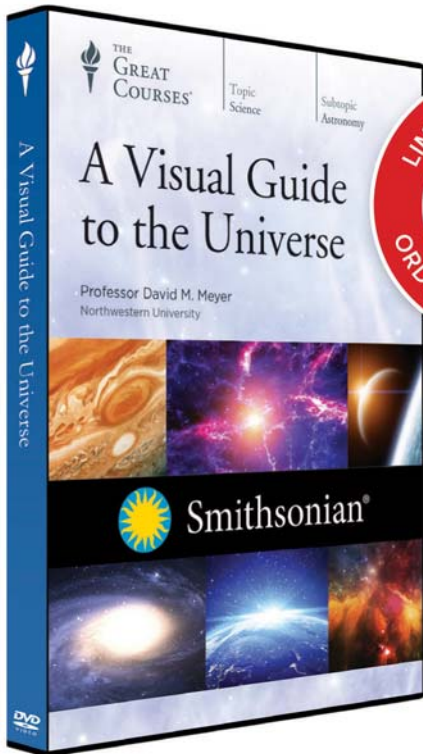

A Visual Guide to the Universe

Taught by Professor David M. Meyer
NORTHWESTERN UNIVERSITY

LECTURE TITLES

1. Probing the Cosmos from Space
2. The Magnetic Beauty of the Active Sun
3. Mars—Water and the Search for Life
4. Vesta and the Asteroid Belt
5. Saturn—The Rings of Enchantment
6. The Ice Moons Europa and Enceladus
7. The Search for Other Earths
8. The Swan Nebula
9. The Seven Sisters and Their Stardust Veil
10. Future Supernova, Eta Carinae
11. Runaway Star, Zeta Ophiuchi
12. The Center of the Milky Way
13. The Andromeda Galaxy
14. Hubble's Galaxy Zoo
15. The Brightest Quasar
16. The Dark Side of the Bullet Cluster
17. The Cosmic Reach of Gamma-Ray Bursts
18. The Afterglow of the Big Bang

Explore the Universe with the Smithsonian

From Saturn's rings to the heart of the Milky Way, and from colliding galaxies to cataclysmic gamma-ray bursts at the edges of visible space, some of the most spectacular sights in the cosmos are now as easy to see as the stars above. **A Visual Guide to the Universe**, produced in partnership with the Smithsonian, takes you there in 18 lavishly illustrated lectures taught by award-winning professor and distinguished astronomer David M. Meyer of Northwestern University.

Among your many adventures, you will orbit Saturn with the *Cassini* probe, see an asteroid up close with the *Dawn* spacecraft, and search for water and life on Mars with the Mars rovers. Looking beyond our solar system, you will witness how an armada of remarkable space telescopes is uncovering the secrets of the cosmos. Embark on our era's greatest voyages of discovery. Without leaving home, you'll find the view is truly out of this world!

Offer expires 12/18/14

THEGREATCOURSES.COM/4SKY
1-800-832-2412

A Visual Guide to the Universe

Course no. 1893 | 18 lectures (30 minutes/lecture)

SAVE \$155

DVD ~~\$219.95~~ NOW \$64.95

+\$10 Shipping, Processing, and Lifetime Satisfaction Guarantee
Priority Code: 105513

For 24 years, The Great Courses has brought the world's foremost educators to millions who want to go deeper into the subjects that matter most. No exams. No homework. Just a world of knowledge available anytime, anywhere. Download or stream to your laptop or PC, or use our free mobile apps for iPad, iPhone, or Android. Over 500 courses available at www.TheGreatCourses.com.

Crystal clear viewing with LUNT Engineering

LUNT 100mm ED APO shown with the optional Red Dot Finder (sold separately)



EXPERIENCE the night sky with both eyes. LUNT 100mm 45° ED APO binoculars allow you to observe spectacular, color free, high power views of planets, double stars and deep space objects. Give us a call or visit our website for complete specifications.

\$2,950

www.luntengineering.com
520.344.7351

Also check out the newest SOLAR scope, the LS50TH α at www.luntsolarsystems.com



www.observa-dome.com

As the country's oldest dome manufacturer, Observa-DOME has developed an expertise unmatched in the industry. Our clients are world-wide, from the United States Government to the amateur astronomer. No matter what the use, the climate, the installation, the design, Observa-DOME meets the challenge.

Alfa Planetarium
Monterrey, Nuevo León, Mexico

PHOTO: ENRIQUE PÉREZ GARCÍA

Phone (601) 982-3333 • (800) 647-5364
Fax (601) 982-3335 • mail@observa-dome.com

371 Commerce Park Drive
Jackson, MS 39213



DARK SKIES INSTANT

Carbon Fiber
REBATE PROMOTION

September 15, 2014 through
October 31, 2014



ED80 APO ▶ **\$150 OFF**
Carbon Fiber



ED102 APO ▶ **\$250 OFF**
Carbon Fiber



ED127 APO ▶ **\$350 OFF**
Carbon Fiber



ED152 APO ▶ **\$700 OFF**
Carbon Fiber

Visit Our Website
For More Information
www.explorescientificusa.com



EXPLORE
SCIENTIFIC

What will you discover™

▶ explorescientificusa.com
866.252.3811

©2014 Explore Scientific



In This Section

- 44 Sky at a Glance
 - 44 Northern Hemisphere Sky Chart
 - 45 Binocular Highlight: The Alpha Persei Association
 - 46 Planetary Almanac
 - 47 Northern Hemisphere's Sky:
The Winter Hunter
 - 48 Sun, Moon & Planets:
Venus and Mercury Draw Close
 - 50 Celestial Calendar
 - 50 Vigil for a Unique Stellar Eclipse
 - 51 Weird R Gem Climbs to Maximum
 - 52 Mutual Events of Jupiter's Moons
 - 52 Lunar Occultations
 - 52 Asteroid Occultations
 - 53 Further Action at Jupiter
 - 53 Phenomena of Jupiter's Moons
 - 54 Exploring the Solar System:
An Observational Mystery
 - 55 Lunar Phases and Librations
 - 56 Deep-Sky Wonders: The Fire Down Below
- Additional Observing Stories:**
- 36 The Backyard Sky Winter

NGC 2174, the Monkey Head Nebula, cloaks the open star cluster NGC 2175 in cosmic dust; see page 39.

PHOTOGRAPH: S&T: SEAN WALKER

OBSERVING Sky at a Glance

JANUARY 2015

- 3, 4 AFTER MIDNIGHT:** The short-lived Quadrantid meteors should peak between these two mornings for North America. A nearly full Moon makes viewing any of this shower's meteors a challenge.
- 5 MIDNIGHT:** Algol shines at minimum brightness for roughly two hours centered at 12:07 a.m. EST; see page 51.
- 7 EVENING:** Algol is at minimum for roughly two hours centered at 8:56 p.m. EST.
- 7 NIGHT:** Look for Jupiter's blaze within 5° of the waning gibbous Moon.
- 8–12 DUSK:** Look low in the southwest sky in early evening to find Mercury and Venus within 1° of each other; see page 48.
- 16 BEFORE DAWN:** Saturn shines about 2° from the waning crescent Moon for North America.
- 21 DUSK:** Look to the west shortly after sunset, where a hairline crescent Moon forms a nearly equilateral triangle with Mercury and Venus (for North America). Bring binoculars. The Moon is to the right of bright Venus.
- 22 DUSK:** The waxing crescent Moon shines about 4° to the right of Mars for North America.
- 23–24 NIGHT:** A rare triple shadow transit occurs on Jupiter from 6:27 to 6:52 a.m. on the 24th UT (1:27 to 1:52 a.m. EST); see page 49.
- 27 NIGHT:** Algol shines at minimum brightness for roughly two hours centered at 10:42 p.m. EST.
- 30 EVENING:** Algol is at minimum for roughly two hours centered at 7:31 p.m. EST.

Using the Map

Go out within an hour of a time listed to the right. Turn the map around so the yellow label for the direction you're facing is at the bottom. That's the horizon. Above it are the constellations in front of you. The center of the map is overhead. Ignore the parts of the map above horizons you're not facing.

EXACT FOR LATITUDE 40° NORTH.

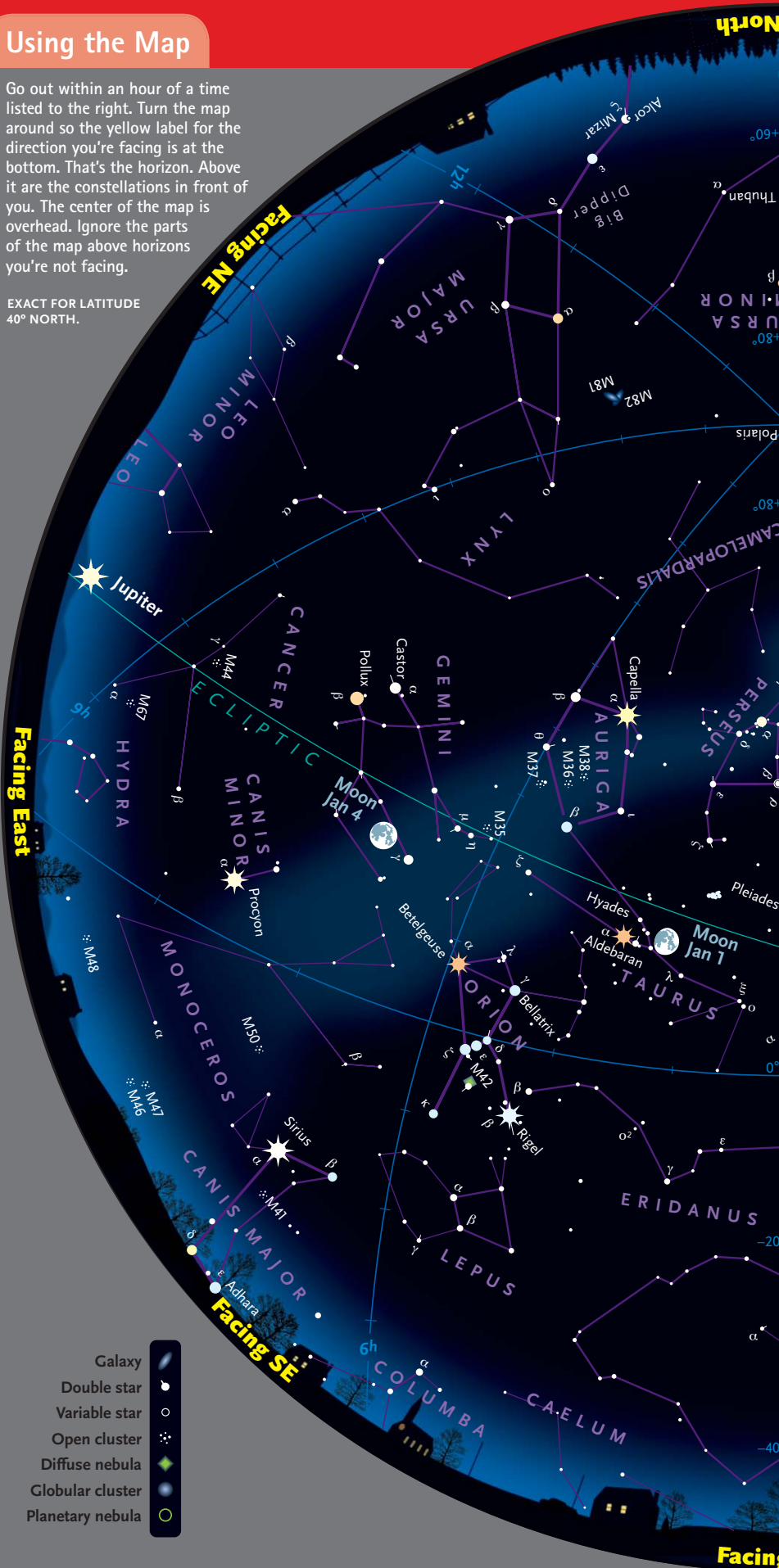

Planet Visibility SHOWN FOR LATITUDE 40° NORTH AT MID-MONTH

	SUNSET	MIDNIGHT	SUNRISE
Mercury	SW	Visible through Jan 22	
Venus	SW		
Mars	SW		
Jupiter		E	S W
Saturn			E SE

Moon Phases

- Full January 4 11:53 p.m. EST
- Last Qtr January 13 4:46 a.m. EST
- New January 20 8:14 a.m. EST
- First Qtr January 26 11:48 p.m. EST

SUN	MON	TUE	WED	THU	FRI	SAT
				1	2	3
4	5	6	7	8	9	10
11	12	13	14	15	16	17
18	19	20	21	22	23	24
25	26	27	28	29	30	31

- Galaxy
- Double star
- Variable star
- Open cluster
- Diffuse nebula
- Globular cluster
- Planetary nebula



When

Late November 11 p.m.
Early December 10 p.m.
Late December 9 p.m.
Early January 8 p.m.
Late January 7 p.m.
These are standard times.

The Alpha Persei Association

Binocular observers tend to work with the same deep-sky catalogs as telescope users, so it's no surprise that the biggest and brightest Messiers and NGCs are also the best known binocular targets. Yet there are some objects that look great in bins, but don't appear on these popular lists. For example, consider the Alpha Persei Association, also known as Melotte 20.

Although the terms "star cluster" and "stellar association" are often used interchangeably, there is a subtle difference between them. Both are groups of stars that formed in the same place at the same time, but members of an association aren't gravitationally bound to one another. Or to put it another way, a star cluster can become an association (thanks to orbital dynamics, stars in older clusters tend to drift apart), but an association won't evolve into an open cluster.

The Alpha Persei Association lies roughly 600 light-years away, and features some two dozen stars brighter than 7th magnitude. Most of these lie between Alpha (α) and Delta (δ) Persei, the two brightest members of the group. Together, association stars fill a binocular field with plenty of sparkle. Indeed, the Alpha Persei group is one of the few objects that looks interesting *only* in binoculars. The unaided eye can perceive only the brightest few stars, whereas the restrictive field of view of a typical telescope excludes too many members for a satisfying view.

Because the Alpha Persei Association has so many bright stars, it's one of the finest binocular deep-sky targets for light-polluted skies. I've viewed it under all kinds of sky conditions and have always enjoyed it. Not bad for an object that didn't make the cut for the Messier or NGC lists! ♦

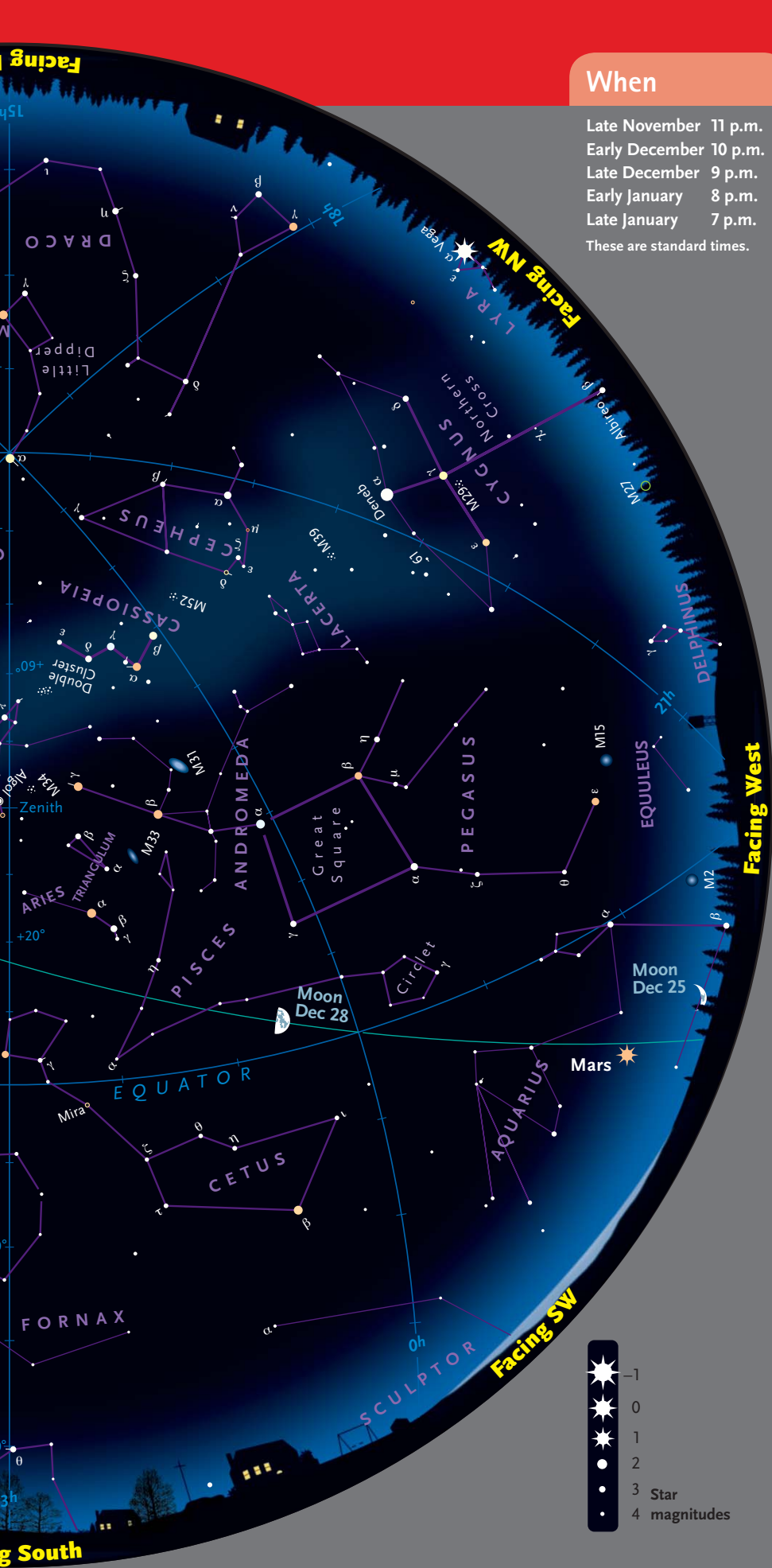

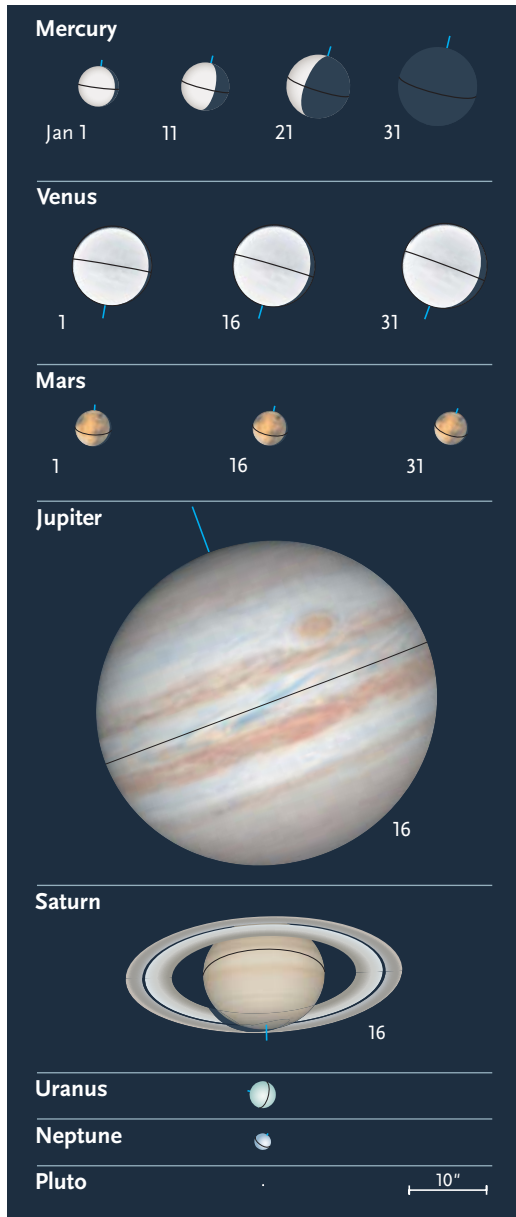

Sun and Planets, January 2015

	January	Right Ascension	Declination	Elongation	Magnitude	Diameter	Illumination	Distance
Sun	1	18 ^h 43.6 ^m	-23° 04'	—	-26.8	32' 32"	—	0.983
	31	20 ^h 52.1 ^m	-17° 35'	—	-26.8	32' 28"	—	0.985
Mercury	1	19 ^h 42.8 ^m	-23° 30'	14° Ev	-0.8	5.3"	91%	1.278
	11	20 ^h 44.9 ^m	-19° 22'	18° Ev	-0.8	6.2"	71%	1.077
	21	21 ^h 15.8 ^m	-14° 46'	16° Ev	+0.3	8.3"	29%	0.814
	31	20 ^h 44.3 ^m	-14° 28'	4° Mo	+5.2	10.2"	1%	0.657
Venus	1	19 ^h 55.3 ^m	-22° 11'	17° Ev	-3.9	10.3"	96%	1.615
	11	20 ^h 47.6 ^m	-19° 28'	19° Ev	-3.9	10.5"	95%	1.585
	21	21 ^h 37.8 ^m	-15° 50'	21° Ev	-3.9	10.8"	94%	1.552
	31	22 ^h 25.8 ^m	-11° 28'	23° Ev	-3.9	11.0"	92%	1.514
Mars	1	21 ^h 34.4 ^m	-15° 37'	41° Ev	+1.1	4.8"	94%	1.970
	16	22 ^h 19.7 ^m	-11° 28'	37° Ev	+1.1	4.6"	95%	2.038
	31	23 ^h 03.4 ^m	-6° 56'	34° Ev	+1.2	4.4"	96%	2.106
Jupiter	1	9 ^h 36.8 ^m	+15° 08'	138° Mo	-2.4	43.4"	100%	4.544
	31	9 ^h 24.2 ^m	+16° 15'	172° Mo	-2.6	45.3"	100%	4.352
Saturn	1	15 ^h 55.7 ^m	-18° 24'	39° Mo	+0.6	15.5"	100%	10.695
	31	16 ^h 06.4 ^m	-18° 51'	67° Mo	+0.5	16.1"	100%	10.297
Uranus	16	0 ^h 47.5 ^m	+4° 23'	77° Ev	+5.8	3.5"	100%	20.198
Neptune	16	22 ^h 30.7 ^m	-10° 08'	40° Ev	+7.9	2.2"	100%	30.712
Pluto	16	18 ^h 57.7 ^m	-20° 38'	12° Mo	+14.2	0.1"	100%	33.760

The table above gives each object's right ascension and declination (equinox 2000.0) at 0^h Universal Time on selected dates, and its elongation from the Sun in the morning (Mo) or evening (Ev) sky. Next are the visual magnitude and equatorial diameter. (Saturn's ring extent is 2.27 times its equatorial diameter.) Last are the percentage of a planet's disk illuminated by the Sun and the distance from Earth in astronomical units. (Based on the mean Earth-Sun distance, 1 a.u. is 149,597,871 kilometers, or 92,955,807 international miles.) For other dates, see SkyandTelescope.com/almanac.

Planet disks at left have south up, to match the view in many telescopes. Blue ticks indicate the pole currently tilted toward Earth.

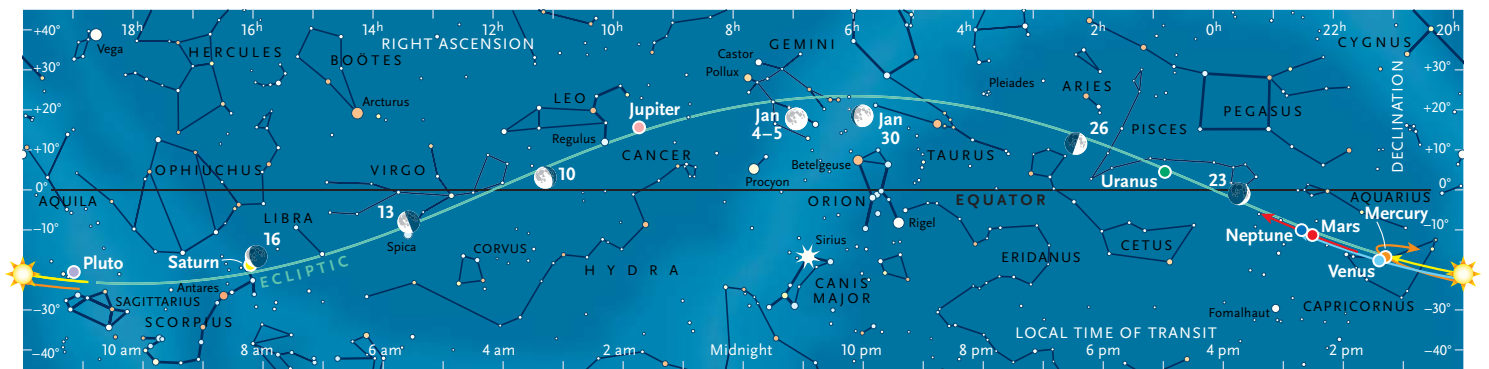

The Sun and planets are positioned for mid-January; the colored arrows show the motion of each during the month. The Moon is plotted for evening dates in the Americas when it's waxing (right side illuminated) or full, and for morning dates when it's waning (left side). "Local time of transit" tells when (in Local Mean Time) objects cross the meridian — that is, when they appear due south and at their highest — at mid-month. Transits occur an hour later on the 1st, and an hour earlier at month's end.



The Winter Hunter

Orion's splendor exceeds that of all other constellations.

When you just look up, which constellation is the most spectacular in the sky? Orion, most amateur astronomers would no doubt say. But I'd go even further. In my opinion, no other constellation comes close to equaling the visual impact of Orion.

Why is that? Let me review some of the reasons Orion virtually brands our minds with its stunning starfire.

The Brightness. Skywatchers often consider Orion the brightest constellation, even though Scorpius stands as summer's brightest for observers at mid-northern latitudes. Mighty Scorpius does include an impressive number of stars brighter than magnitude 2.5, and an even more impressive number brighter than 3.0. But it has only one 1st-magnitude star, Antares, which is always dimmer than Orion's Rigel, and almost always dimmer than Orion's variable Betelgeuse.

If you watch the heavens from farther south, you might name Centaurus and Crux as constellations that, like Orion, contain two 1st-magnitude stars. But Orion also features a remarkable supporting cast: the other five stars of its main pattern are all 2nd magnitude. Fainter stars define the less symmetrical, more rambling pattern of Centaurus. But what about Crux, with its very compact, very striking symmetrical pattern? The "missing" bright star at its center often disappoints first-time viewers. Crux's fourth-brightest star shines at magnitude 2.8, which is relatively feeble compared to the 2.2 of Orion's 7th-brightest star (the faintest in Orion's main pattern).

The Pattern. The brightness of Orion's stars is accentuated by their placement in one of the sky's two most eye-catching patterns of stars in the mid-size range (say about 10° to 30° across). The other such pattern is not a constellation but a large asterism: the Big Dipper. The Big Dipper has one more 2nd-magnitude star than Orion, but no 1st-magnitude star to compete with Orion's Rigel and Betelgeuse. Additionally, the least bright star of the Big Dipper's seven, Megrez, is a surprisingly dim magnitude 3.3.

Orion has the tremendous plus of the Belt as well. Unless we count the tiny dipper of the brightest Pleiades stars, there is no small asterism that can compare with the row of three bright stars in Orion's Belt. I've written before of my amazement when I once saw first one bright star, then another almost identically bright, break into view through a tiny gap in extensive cloud cover. These were the two more easterly stars of the Belt. No such



The red glow of Betelgeuse marks the shoulder of a rising Orion.

arrangement of just two stars — let alone three — could compete with this asterism for catching the eye.

Of course, when we consider the larger patterns of Orion and the Big Dipper, we have to acknowledge how comforting it is to see the familiar form of a saucepan or ladle hanging in the north. Some cultures have seen a plow here, though, and for many the seven stars of our modern Big Dipper were part of a larger pattern forming a bear — a strange long-tailed beast. Both interpretations are memorable and evocative, but in many cultures throughout history, Orion's main stars have suggested the form of the greatest possible interest to sky watchers: the human body itself.

Artistry Beyond Analysis. We can say more. The symmetries associated with Orion's form are amazing: the Belt is about halfway between Betelgeuse and Rigel, and halfway between Sirius and Aldebaran or the Hyades. It's jauntily aslant in relation to the north-south orientation of the larger frame of Orion's body. Like all good art, Orion's form deviates a little from what would otherwise be a boringly perfect symmetry. And as with great art, some of what makes Orion fascinating to our eye seems to go, wondrously and beautifully, beyond all analysis. ♦

Venus and Mercury Draw Close

Nightfall reveals a planetary pairing.

For much of January, brilliant Venus and lesser Mercury are paired low in the west-southwest, with much dimmer Mars well to their upper left. On the opposite side of the sky, Jupiter comes up ever earlier in the evening as January progresses, in bright

twilight by month's end. Jupiter transits the meridian not long after midnight. Saturn rises long after midnight but is high enough for good viewing by dawn.

DUSK & SOON AFTER

Venus and **Mercury** linger prominently near each other at dusk through the first half of January. Spot them low in the west-southwest. Look for Mercury to the lower right of Venus for the first week or so of the month, then to Venus's right through about the 17th.

Venus shines all month at magnitude -3.9 . Mercury dims from -0.8 on January 1st to -0.4 on the 17th, then fades very rapidly (0.0 on the 19th, $+0.3$ on the 21st, $+1.4$ on the 23rd). Mercury is never more than about 7° high 45 minutes after sunset for viewers at mid-northern latitudes. That altitude still makes this the second highest evening display of Mercury in 2015.

But what's really exciting is the apparent separation between the two planets. From January 8th through 12th, Venus and

Mercury stay within 1° of each other. Their least separation, $39'$, comes on January 10th around 7 p.m. EST, right around their best viewing time for the Americas. And yet there is no actual conjunction in right ascension during this encounter. The event is a particularly close "quasi-conjunction" — two planets coming to within 5° of each other without ever having the same right ascension. This is the first quasi-conjunction of bright planets since July 2012, and the closest since a similar encounter of Mercury and Venus back in 2001.

This is also the nearest together Mercury and Venus have been since 2012 and their closest readily observable pairing (with both planets far enough from the Sun) since 2005. During this close encounter, telescopes show Venus as an almost imperceptibly out-of-round disk only about $10.5''$ wide. Mercury looks like a distinctly gibbous disk $6''$ to $7''$ wide.

Mercury reaches a greatest elongation of 19° from the Sun on January 14th, appearing a little more than half-lit. During the following week Mercury fades, its phase quickly thins, and it starts dropping farther away to the lower right of Venus. Mercury is soon lost from view and plummets through inferior conjunction with the Sun on January 30th.

Mars glows far dimmer than Venus and, for most of the month, than Mercury. Look for it about 20° (two fist-widths at arm's length) to the upper left of the pair. Mars shines at only magnitude $+1.1$ to $+1.2$, and in telescopes it's less than $5''$ wide.

On January 19th, a telescope can show 8th-magnitude **Neptune** just $\frac{1}{4}^\circ$ north (upper right) of Mars once the sky darkens. On the last evening of January and the first of February, Neptune is hardly more than 1° from Venus.

Uranus can be found higher in the southwest at the end of dusk (see [skypub](#)).

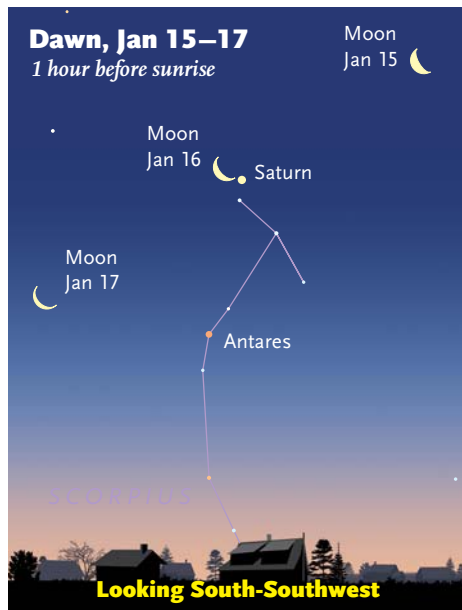
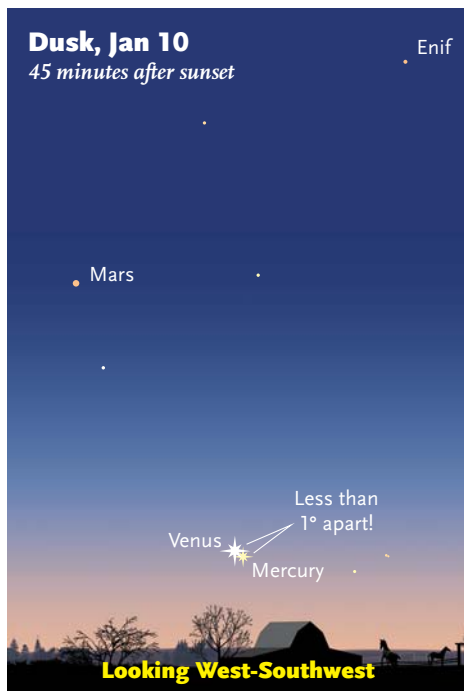
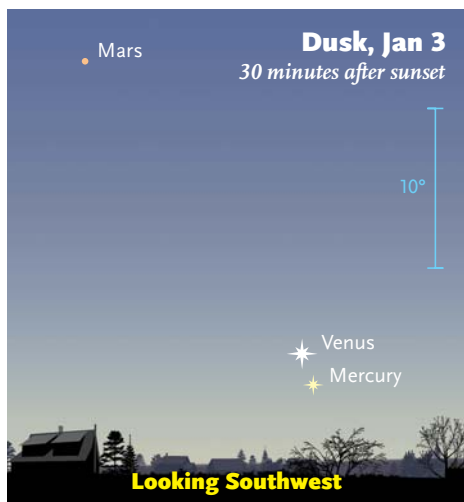



ORBITS OF THE PLANETS

The curved arrows show each planet's movement during January. The outer planets don't change position enough in a month to notice at this scale.

com/urnep for finder charts for Uranus and Neptune).

Pluto is in conjunction with the Sun on January 3rd and is therefore not viewable this month.

ALL NIGHT LONG

Jupiter, in Leo, comes up around 8 p.m. as January begins, but only about 20 minutes after sunset as the month ends. The magnificent world brightens from -2.4 to -2.6 during January and swells from $43.5''$ to $45.3''$ wide in the telescope. Jupiter will reach opposition on February 6th, but the planet is already a rich and splendid sight through the eyepiece.

Jupiter starts January about 10° above Regulus as they ascend the eastern sky. But the giant world retrogrades noticeably farther from Regulus during the month; they end January almost 12° apart.

A rare attraction occurs on the American night of January 23–24, when three of

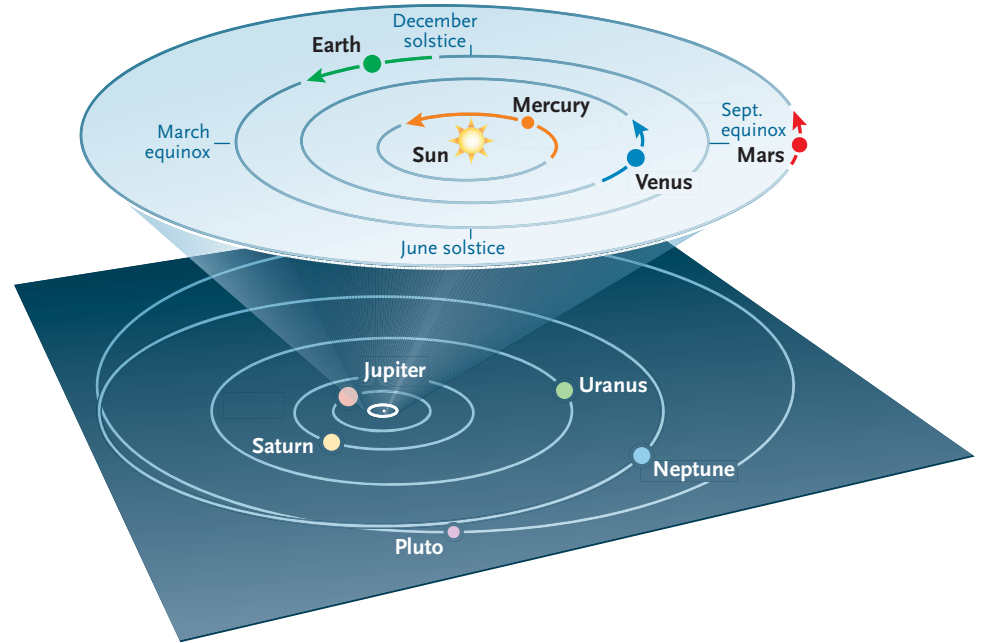

the Galilean satellites cast their tiny black shadows onto Jupiter at once.

PRE-DAWN & DAWN

Saturn rises after 4 a.m. in the opening days of 2015, but by month's end it's coming up around 2:30 a.m. The ringed world

glows at magnitude $+0.5$ with an equatorial diameter of about $16''$. The rings are tilted nearly 24° from edge-on this month. Saturn creeps east relative to the stars in January and by the end of the month has come to within a little more than a degree north of the double star Beta (β) Scorpii (Graffias).

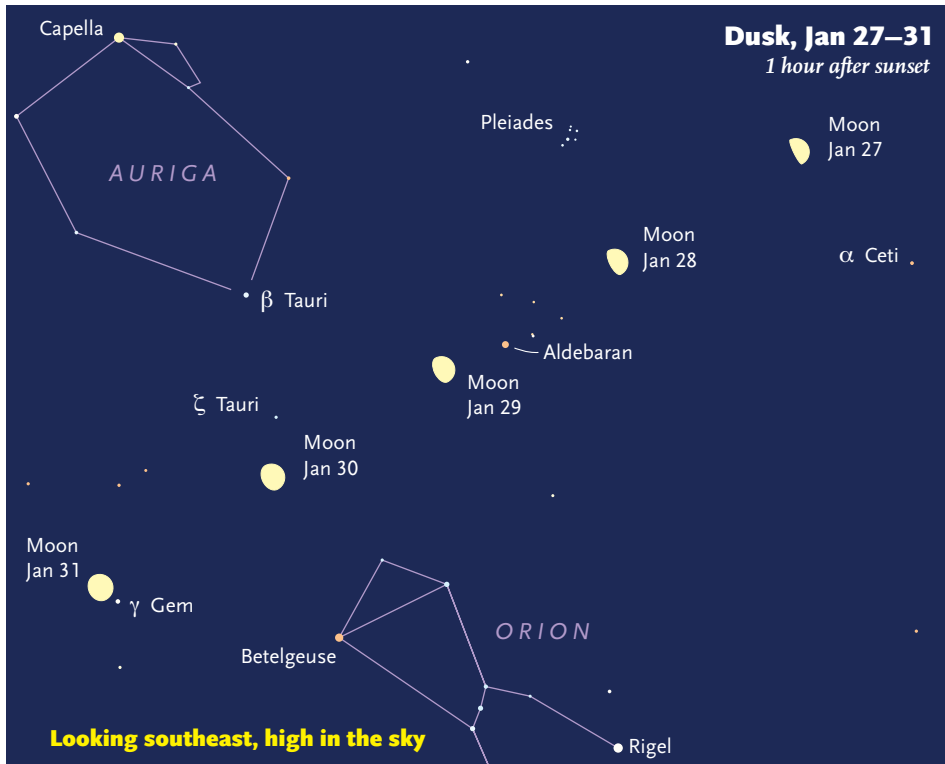

EARTH

Earth reaches perihelion, closest to the Sun in space, on January 4th at 1:37 a.m. EST (January 3rd at 10:37 p.m. PST). It is then 0.983277 a.u. from the Sun, only one part in 30 closer than at aphelion in July.

MOON PASSAGES

The **Moon** is just past full when it rises to the right of Jupiter on the evening of January 7th and to the lower right of Regulus below Jupiter the next night. The last-quarter Moon is close above Spica at dawn on January 13th. The waning lunar crescent hangs very near Saturn and Beta Scorpii at dawn on January 16th.

At dusk on January 21st, the thin waxing lunar crescent is about 6° right of Venus and only about 4° above dimming Mercury. A thicker Moon hangs a few degrees right of Mars on January 22nd. The waxing gibbous Moon is left of Aldebaran on the evening of the 29th and much closer to Gamma Geminorum on the 31st. ♦

Vigil for a Unique Stellar Eclipse

Against incredible odds, this naked-eye star may self-eclipse for the first time seen.

Imagine two ping-pong balls averaging 200 feet apart, revolving widely around each other every 26 years. That's a good scale model of the visual binary star Alpha (α) Comae Berenices. It's a pair of *F5* stars a little larger and hotter than the Sun, about 63 light-years away and shining in our sky at a combined magnitude of 4.3. The pair is a visual binary: barely resolvable in some large amateur telescopes when the stars are at their maximum separation of 0.7 arcsecond.

The pair is remarkable for its orbit being inclined almost exactly 90° to the plane of the sky. We see the orbit so close to edge on that one of the stars may be about to eclipse the other, as unlikely as this would seem for two ping-pong balls so far apart. Judging from recent high-precision astrometry, an eclipse is "highly

likely" in the second half of January, says astrometrist Matthew Muterspaugh (Tennessee State University). The most likely dates are January 23rd and 24th.

The eclipse could last for up to 1½ days, depending on how central or grazing it turns out to be. A central eclipse would dim the system by 0.7 or 0.8 magnitude for several hours, quite enough to detect with the naked eye.

Writes Muterspaugh, "We anticipate continued astrometric monitoring leading up to the event. We will be observing this star with the Navy Precision Optical Interferometer (NPOI) starting December 10th. This should greatly refine the timing prediction."

The American Association of Variable Star Observers (AAVSO) is coordinating a worldwide observing campaign for this

event. The website for the project is aavso.org/observing-campaign-alf-Com. More news may be up by the time you read this.

The last time an eclipse of Alpha Comae may have happened was February 1989, as we predicted in that month's *Sky & Telescope*. But the date was hazier than this time, the likelihood of any eclipse seemed small, and not enough readers kept a continuous enough watch to tell whether it occurred or not.

Now, many of you can do precision photometry with automated setups that can run for hours on end. All you really need is a DSLR camera and instructions in the new *AAVSO DSLR Observing Manual*, which starts at the beginner level. You can download the manual for free at aavso.org/dslr-observing-manual. An astronomical CCD camera can do better, as told in the *AAVSO Guide to CCD Photometry*, aavso.org/ccd-photometry-guide.

And there's certainly still a place for careful naked-eye and binocular observers.

You can use the comparison stars labeled on the photo at left. Many readers will recognize Alpha Comae as the bright star located 1° southwest of the 8th-magnitude globular cluster M53. In late January this part of the sky rises well up in the east by midnight.

If observers this time record an eclipse, Alpha Comae will become the longest-period normal eclipsing binary star (not counting Epsilon Aurigae, whose eclipse is caused by a disk of dark dust). It will also be just the second star that is both a visual and an eclipsing binary (Gamma Persei was the first, as discovered in 1990). And it will be *by far* the widest known eclipsing binary with more or less Sun-like main-sequence stars. If the star-formation dice were re-rolled to give this system a random inclination, it would have only about a 1 in 1,200 chance of eclipsing.

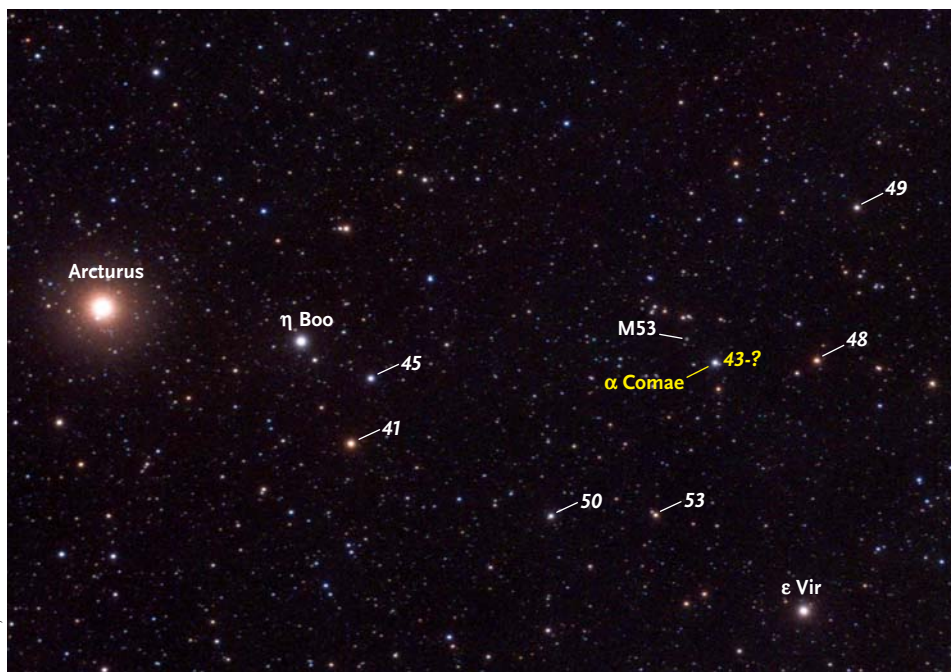

Alpha Comae Berenices, 15° west of Arcturus, shines at magnitude 4.3 — but maybe not always. Comparison-star magnitudes (courtesy AAVSO) are given here to the nearest tenth with the decimal point omitted.



Weird R Gem Climbs to Maximum

Gemini glitters in the eastern sky on December and January evenings (see the map on page 44), and right in its middle is R Geminorum, a long-period red variable star now on its way up from minimum light.

Its period is a year and five days. R Gem

was at its minimum in October at magnitude 13.2. By January 1st it should be about 9.5 or 9.0, and by February 1st it should be close to its maximum of about 7.1, which the AAVSO predicts for late February. Its peak brightness often differs from one cycle to the next; the

brightest R Gem has ever been seen is 6.0. It should spend the following months fading more slowly. Use the comparison-star chart below, and the link in the caption if necessary, to estimate its brightness as it rises.

Like all Mira-type variables, R Gem is a red giant in its unstable late stages of life. Violent events have begun at its increasingly hot, dense core, and its surface is streaming away as a thick stellar wind. Even among Miras, though, R Gem is special. It's one of the brightest stars of spectral type S, a type paralleling M giants but with spectra showing zirconium oxide, yttrium oxide, and technetium. These rare elements form by other heavy elements slowly capturing neutrons in or near the star's increasingly extreme core. The zirconium in your zircon ($ZrSiO_4$) or cubic zirconia (ZrO_2) jewelry originated inside red giants like this one, before the solar system and Earth were born.

Astronomers were especially surprised to identify technetium in S stars' spectra, in 1952. Technetium is an "artificial" element, as its name implies, made in nuclear reactors; its longest-lived isotope has a half-life of just 4.2 million years. So it must have been dredged up from these stars' active cores relatively recently. R Gem shows an unusual amount of it even for an S star.



AKIRA FUJII

R Geminorum, hiding between the Gemini stick figures, may be the only place where you'll ever look at the element technetium. (Here the star is about magnitude 8.9)

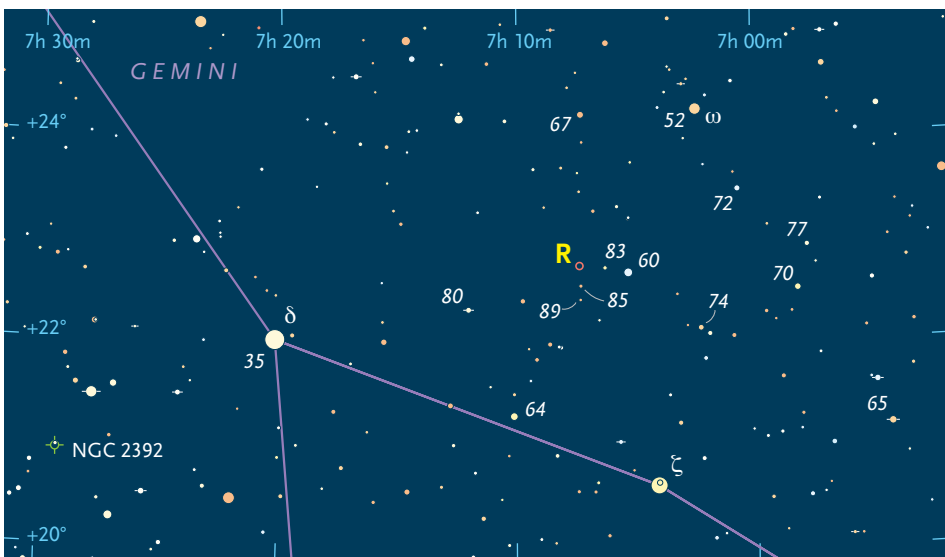

Comparison stars around R Gem are labeled with their visual magnitudes to the tenth with the decimal point omitted. For deeper charts, enter "R Gem" in the Pick a Star box at aavso.org.

Minima of Algol

Dec.	UT	Jan.	UT
1	19:17	2	8:18
4	16:06	5	5:07
7	12:55	8	1:56
10	9:44	10	22:46
13	6:33	13	19:35
16	3:22	16	16:24
19	0:12	19	13:14
21	21:01	22	10:03
24	17:50	25	6:52
27	14:39	28	3:42
30	11:28	31	0:31

Jupiter's Moons

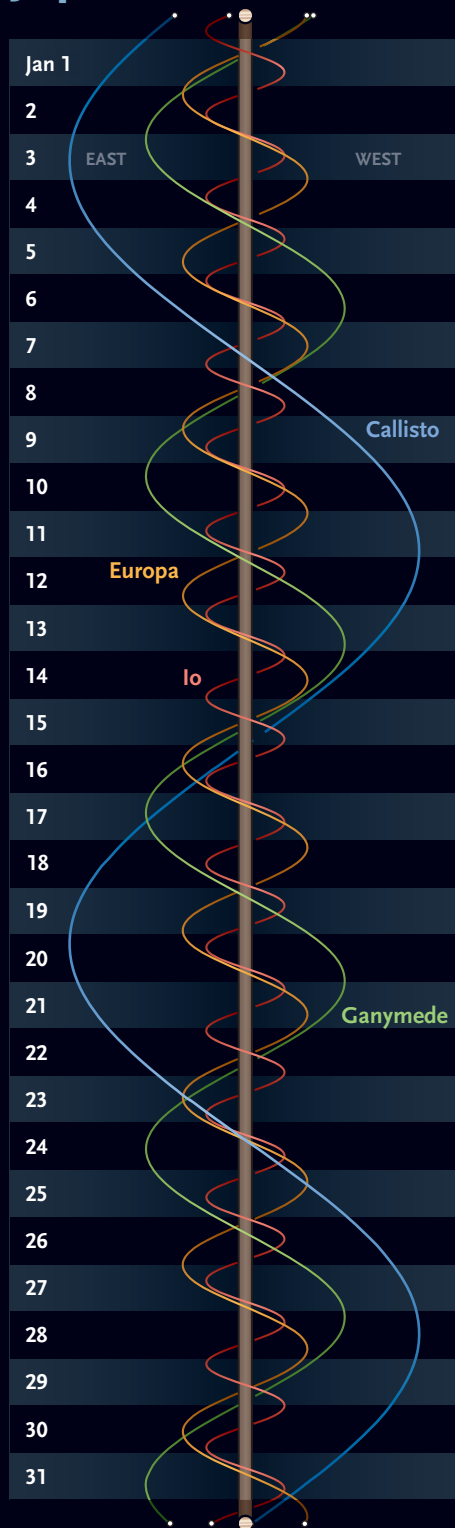

The wavy lines represent Jupiter's four big satellites. The central vertical band is Jupiter itself. Each gray or black horizontal band is one day, from 0^h (upper edge of band) to 24^h UT (GMT). UT dates are at left. Slide a paper's edge down to your date and time, and read across to see the satellites' positions east or west of Jupiter.

Mutual Events of Jupiter's Moons

We're now in a season of mutual eclipses and occultations among Jupiter's four big satellites *themselves*. These events will continue until Jupiter disappears into the sunset this summer.

In December and January more than 50 of these events happen when Jupiter is in a dark sky for at least part of the continental U.S., but many involve only slight dimmings. Listed below are the deepest ones: where the shadowed satellite, or the blend of two satellites during a mutual occultation, fades by at least 0.5 magnitude at mid-event:

Deep Mutual Events of Jupiter's Moons (for North America)

Date (UT)	Event	Start UT	End UT	Mag. drop
Dec. 20	2o1	5:31	5:52	0.5
21	4e1	3:13	3:32	1.1
21	4e1	11:49	12:12	1.1
24	2e3	6:24	6:45	0.6
28	3o1	7:39	7:59	0.5
31	2e3	10:45	11:13	0.6
Jan. 15	1e4	12:13	12:39	0.5
19	3o2	2:31	2:37	0.5
23	4e3	9:06	9:20	1.4
26	3o2	5:13	5:19	0.5
28	2e1	6:18	6:27	0.5
29	1o2	14:31	14:35	0.6

Lunar Occultations

Late on the night of January 1–2, as the waxing gibbous Moon crosses the Hyades, the Moon's invisible dark limb will cover Delta¹ and/or Delta² Tauri (magnitudes 3.8 and 4.8, respectively) for much of the southern and western U.S. In a telescope, watch as the Moon creeps up and perhaps snuffs them out. For detailed timetables for many locations, check lunar-occultations.com/iota/bstar/bstar.htm as the date nears.

Under "Event," satellite 1 is Io, 2 is Europa, 3 is Ganymede, and 4 is Callisto; o means occults, and e means eclipses.

For instance, from 5:31 to 5:52 December 20th UT (12:31 to 12:52 a.m. on the 20th EST), Europa crosses in front of Io. Their combined light is reduced by 0.5 magnitude at mid-occultation. That much dimming (a 37% loss of light) should be observable if you compare carefully with the other satellites. Drops of 1 magnitude or more will be much plainer.

For all of the events visible worldwide, sortable by your location, see skypub.com/jovianmutualevents. There you'll also find links to the global campaign to record them photometrically, for refining the slight but interesting and important long-term changes in the Jovian satellites' orbits.

Asteroid Occultations

- **Late on the night of January 10–11**, a 9.9-magnitude star at the Leo-Cancer border will vanish for up to 1.2 seconds behind the faint asteroid 1333 Cevenola (which may be binary) as seen from a narrow track from South Carolina past Atlanta, Indianapolis, Chicago, Minneapolis, and Winnipeg.
 - **On the morning of January 14th**, an 8.7-magnitude star in Auriga will be occulted by faint 753 Tiflis for up to 2.6 seconds as seen from a narrow track running from northern New Mexico through northern California.
 - **On the morning of January 20th**, an 8.5-magnitude star in Libra will snap out behind faint 110 Lydia for up to 4 seconds along a path from Yukon past Winnipeg, across the Great Lakes, New Jersey, and maybe New York City.
 - **Just before dawn on January 30th**, faint, slow-moving 166 Rhodope will occult a magnitude-7.6 star in Virgo for up to 8 seconds along a track from Louisiana through Lake Superior.
- For time predictions, track maps, and finder charts for the stars, see asteroidoccultation.com/IndexAll.htm.

Further Action at Jupiter

Jupiter is nearing its February 6th opposition, shining big and bright between Leo and Cancer, high in the east by late evening.

Any telescope shows Jupiter's four big Galilean moons. Binoculars usually show at least two or three of them, occasionally all four. Identify them using the diagram on the facing page.

All the interactions between Jupiter and its satellites and their shadows are tabulated below.

And here are the times, in Universal Time, when the Great Red Spot should cross Jupiter's central meridian. The dates, also in UT, are in bold. (Eastern Standard Time is UT minus 5 hours.)

December 1, 6:01, 15:57; **2**, 1:52, 11:48, 21:44; **3**, 7:39, 17:35; **4**, 3:30, 13:26, 23:22; **5**, 9:17, 19:13;

6, 5:09, 15:04; **7**, 1:00, 10:56, 20:51; **8**, 6:47, 16:42; **9**, 2:38, 12:34, 22:29; **10**, 8:25, 18:21; **11**, 4:16, 14:12; **12**, 0:07, 10:03, 19:59; **13**, 5:54, 15:50; **14**, 1:46, 11:41, 21:37; **15**, 7:32, 17:28; **16**, 3:24, 13:19, 23:15; **17**, 9:10, 19:06; **18**, 5:02, 14:57; **19**, 0:53, 10:48, 20:44; **20**, 6:40, 16:35; **21**, 2:31, 12:27, 22:22; **22**, 8:18, 18:13; **23**, 4:09, 14:05; **24**, 0:00, 9:56, 19:51; **25**, 5:47, 15:43; **26**, 1:38, 11:34, 21:29; **27**, 7:25, 17:21; **28**, 3:16, 13:12, 23:07; **29**, 9:03, 18:59; **30**, 4:54, 14:50; **31**, 0:45, 10:41, 20:36.

January 1, 6:35, 16:31; **2**, 2:27, 12:22, 22:18; **3**, 8:13, 18:09; **4**, 4:05, 14:00, 23:56; **5**, 9:51, 19:47; **6**, 5:42, 15:38; **7**, 1:34, 11:29, 21:25; **8**, 7:20, 17:16; **9**, 3:12, 13:07, 23:03; **10**, 8:58, 18:54; **11**, 4:49, 14:45; **12**, 0:41, 10:36, 20:32; **13**, 6:27, 16:23; **14**, 2:19, 12:14, 22:10; **15**, 8:05, 18:01; **16**, 3:56, 13:52, 23:48; **17**, 9:43, 19:39; **18**, 5:34, 15:30; **19**, 1:25, 11:21, 21:17; **20**, 7:12, 17:08; **21**, 3:03, 12:59, 22:54; **22**, 8:50,

18:46; **23**, 4:41, 14:37; **24**, 0:32, 10:28, 20:24; **25**, 6:19, 16:15; **26**, 2:10, 12:06, 22:01; **27**, 7:57, 17:53; **28**, 3:48, 13:44, 23:39; **29**, 9:35, 19:30; **30**, 5:26, 15:22; **31**, 1:17, 11:13, 21:08.

These times assume that the spot is centered at about System II longitude 230°. Any feature on Jupiter appears closer to the central meridian than to the limb for 50 minutes before and after transiting. A light blue or green filter slightly boosts the contrast of Jupiter's reddish, orange, and tan markings. ♦

MOONLIT QUADRANTIDS

The brief Quadrantid meteor shower, due to peak around 2^h UT January 4th, will be largely washed out by nearly full moonlight this year.

Phenomena of Jupiter's Moons, January 2015

Jan. 1	3:18 III.Ec.D 4:00 II.Ec.D 4:27 I.Sh.I 5:15 I.Tr.I 6:44 I.Sh.E 7:32 I.Tr.E 8:30 II.Oc.R 10:19 III.Oc.R	11:56 II.Sh.I 12:34 I.Tr.I 13:24 II.Tr.I 14:08 I.Sh.E 14:51 II.Sh.E 14:51 I.Tr.E 16:19 II.Tr.E	19:16 I.Sh.I 19:50 II.Ec.D 19:53 I.Tr.I 21:16 III.Sh.I 21:34 I.Sh.E 22:10 I.Tr.E 23:44 III.Tr.I 23:55 II.Oc.R	Jan. 16	2:39 IV.Oc.R 5:27 I.Ec.D 8:18 I.Oc.R	Jan. 21	12:53 I.Ec.D 15:36 I.Oc.R	6:21 III.Tr.I 8:52 III.Sh.E 9:59 III.Tr.E 20:19 I.Ec.D 22:54 I.Oc.R							
Jan. 2	1:39 I.Ec.D 4:47 I.Oc.R 22:39 II.Sh.I 22:55 I.Sh.I 23:41 I.Tr.I	Jan. 7	9:05 I.Ec.D 9:13 IV.Sh.I 12:06 I.Oc.R 14:02 IV.Sh.E 15:49 IV.Tr.I 20:31 IV.Tr.E	Jan. 12	0:54 III.Sh.E 3:21 III.Tr.E 16:30 I.Ec.D 19:25 I.Oc.R	Jan. 17	2:41 I.Sh.I 3:11 I.Tr.I 3:51 II.Sh.I 4:52 II.Tr.I 4:59 I.Sh.E 5:28 I.Tr.E 6:46 II.Sh.E 7:46 II.Tr.E 23:56 I.Ec.D	Jan. 22	10:06 I.Sh.I 10:29 I.Tr.I 11:40 II.Ec.D 12:24 I.Sh.E 12:46 I.Tr.E 15:13 III.Ec.D 15:17 II.Oc.R 20:23 III.Oc.R	Jan. 27	17:32 I.Sh.I 17:46 I.Tr.I 19:45 II.Sh.I 19:49 I.Sh.E 20:04 I.Tr.E 20:15 II.Tr.I 22:40 II.Sh.E 23:10 II.Tr.E				
Jan. 3	0:15 II.Tr.I 1:12 I.Sh.E 1:33 II.Sh.E 1:58 I.Tr.E 3:09 II.Tr.E 20:08 I.Ec.D 23:14 I.Oc.R	Jan. 8	6:20 I.Sh.I 6:34 II.Ec.D 7:00 I.Tr.I 7:17 III.Ec.D 8:37 I.Sh.E 9:17 I.Tr.E 10:47 II.Oc.R 13:44 III.Oc.R	Jan. 13	13:45 I.Sh.I 14:19 I.Tr.I 14:33 II.Sh.I 15:43 II.Tr.I 16:02 I.Sh.E 16:36 I.Tr.E 17:27 II.Sh.E 18:37 II.Tr.E	Jan. 18	2:44 I.Oc.R 21:10 I.Sh.I 21:37 I.Tr.I 22:24 II.Ec.D 23:27 I.Sh.E 23:54 I.Tr.E	Jan. 23	7:22 I.Ec.D 10:02 I.Oc.R	Jan. 24	3:11 IV.Sh.I 4:35 I.Sh.I 4:55 I.Tr.I 6:19 IV.Tr.I 6:28 II.Sh.I 6:52 I.Sh.E 7:08 II.Tr.I 7:12 I.Tr.E 8:00 IV.Sh.E 9:22 II.Sh.E 10:02 II.Tr.E 11:02 IV.Tr.E	Jan. 28	14:47 I.Ec.D 17:20 I.Oc.R	Jan. 29	12:00 I.Sh.I 12:12 I.Tr.I 14:14 II.Ec.D 14:17 I.Sh.E 14:29 I.Tr.E 17:30 II.Oc.R 19:12 III.Ec.D 23:40 III.Oc.R
Jan. 4	17:17 II.Ec.D 17:19 III.Sh.I 17:23 I.Sh.I 18:08 I.Tr.I 19:40 I.Sh.E 20:21 III.Tr.I 20:25 I.Tr.E 20:56 III.Sh.E 21:39 II.Oc.R 23:58 III.Tr.E	Jan. 9	3:33 I.Ec.D 6:33 I.Oc.R	Jan. 14	10:59 I.Ec.D 13:51 I.Oc.R	Jan. 19	1:15 III.Sh.I 2:10 II.Oc.R 3:04 III.Tr.I 4:53 III.Sh.E 6:42 III.Tr.E 18:24 I.Ec.D 21:10 I.Oc.R	Jan. 25	1:50 I.Ec.D 4:28 I.Oc.R 23:03 I.Sh.I 23:20 I.Tr.I	Jan. 26	0:57 II.Ec.D 1:21 I.Sh.E 1:38 I.Tr.E 4:24 II.Oc.R 5:13 III.Sh.I	Jan. 30	9:16 I.Ec.D 11:46 I.Oc.R	Jan. 31	6:28 I.Sh.I 6:38 I.Tr.I 8:46 I.Sh.E 8:55 I.Tr.E 9:04 II.Sh.I 9:23 II.Tr.I 11:59 II.Sh.E 12:18 II.Tr.E
Jan. 5	14:36 I.Ec.D 17:40 I.Oc.R	Jan. 10	0:48 I.Sh.I 1:15 II.Sh.I 1:26 I.Tr.I 2:34 II.Tr.I 3:05 I.Sh.E 3:44 I.Tr.E 4:09 II.Sh.E 5:29 II.Tr.E 22:02 I.Ec.D	Jan. 15	8:13 I.Sh.I 8:45 I.Tr.I 9:07 II.Ec.D 10:30 I.Sh.E 11:02 I.Tr.E 11:15 III.Ec.D 13:03 II.Oc.R 16:48 IV.Ec.D 17:05 III.Oc.R 21:42 IV.Ec.R 21:52 IV.Oc.D	Jan. 20	15:38 I.Sh.I 16:03 I.Tr.I 17:09 II.Sh.I 17:55 I.Sh.E 17:59 II.Tr.I 18:20 I.Tr.E 20:04 II.Sh.E 20:54 II.Tr.E	Jan. 26	1:50 I.Ec.D 4:28 I.Oc.R 23:03 I.Sh.I 23:20 I.Tr.I						
Jan. 6	11:51 I.Sh.I	Jan. 11	0:59 I.Oc.R												

Every day, interesting events happen between Jupiter's satellites and the planet's disk or shadow. The first columns give the date and mid-time of the event, in Universal Time (which is 5 hours ahead of Eastern Standard Time). Next is the satellite involved: I for Io, II Europa, III Ganymede, or IV Callisto. Next is the type of event: Oc for an occultation of the satellite behind Jupiter's limb, Ec for an eclipse by Jupiter's shadow, Tr for a transit across the planet's face, or Sh for the satellite casting its own shadow onto Jupiter. An occultation or eclipse begins when the satellite disappears (D) and ends when it reappears (R). A transit or shadow passage begins at ingress (I) and ends at egress (E). Each event is gradual, taking up to several minutes. Predictions courtesy IMCCE / Paris Observatory.

An Observational Mystery

What causes Io's enigmatic brightening?

For telescopic observers, Jupiter's satellite Io is hardly a showpiece object. Although 5% larger than the Moon, Io is 2,000× more distant and, under optimal conditions, can barely be distinguished as a non-stellar disk through a 5-inch telescope. Observing Io is like observing a penny from a distance of almost 3 miles.

For more than a century, Io has been the subject of a number of observing conundrums — a number that is out of all proportion to its diminutive apparent size. In his popular 1954 book *Guide to the Planets*, Patrick Moore wrote: "Io sometimes shows peculiar fluctuations in brilliancy, and I once saw it brighten up strikingly in the space of a few hours for no apparent reason."

In 1964 astronomers Alan Binder and Dale Cruikshank reported that observations of Io with a photoelectric photometer revealed that the satellite brightens temporarily when it emerges from Jupiter's shadow following eclipses. This post-eclipse anomaly, which typically amounted to a 10% to 15% increase in brightness, usually persisted for up to 20 minutes. The other Galilean satellites, Europa, Ganymede, and Callisto, never displayed this strange behavior.

These photometric observations were very challenging because for earthbound observers, eclipses of Io occur when the satellite is less than one Jupiter radius (about

20 arcseconds) from its brilliant parent planet. Scattered light from nearby Jupiter detracts from the accuracy of the brightness measurements of Io to a greater degree than for the other Galilean satellites, whose eclipse phenomena generally occur at considerably larger angular distances from Jupiter. Nevertheless, the fact that no corresponding brightening was detected at very similar viewing geometries just before Io entered Jupiter's shadow lent credence to the notion that the phenomenon had some basis in reality.

Cruikshank insightfully proposed that Io has a tenuous atmosphere containing an unknown gas that freezes out when Io plunges into Jupiter's icy shadow, where it remains for just over two hours during an eclipse. He suggested that as Io re-emerges into sunlight at the end of an eclipse, frozen gas in the form of bright frost deposits blanketing the moon's surface should reflect more sunlight briefly before evaporating and restoring Io to its normal brightness.

Despite this plausible explanation, the phenomenon proved frustratingly sporadic and unpredictable. Observations in visible light during the early 1970s of a dozen eclipses of Io by teams of astronomers at Mauna Kea and Cerro Tololo observatories failed to detect any anomalous post-eclipse brightenings, but in 1971 photometric measurements conducted independently at Kitt Peak and Table Mountain observatories convincingly recorded a post-eclipse brightening that was more pronounced in the near-ultraviolet region of the spectrum at wavelengths of 350 to 400 nanometers than it was in visible light. Two years later, Cruikshank and his colleague Robert Murphy reported that they had detected Io's post-eclipse brightening on some occasions during the previous two years but not on others.

In 1979 the twin Voyager spacecraft obtained the first high-resolution images of Io, revealing the presence of a host of volcanoes erupting with colossal violence, hurling plumes of ejecta hundreds of kilometers above an alien landscape dotted with lakes of molten sulfur and drifts of sulfur dioxide snow. The tides raised by the gravitational tug of war between the enormous mass of nearby Jupiter and the other Galilean satellites knead the interior of Io, fueling volcanic activity so intense that the surface of the satellite is continually re-surfaced with new layers of material vented by eruptions.

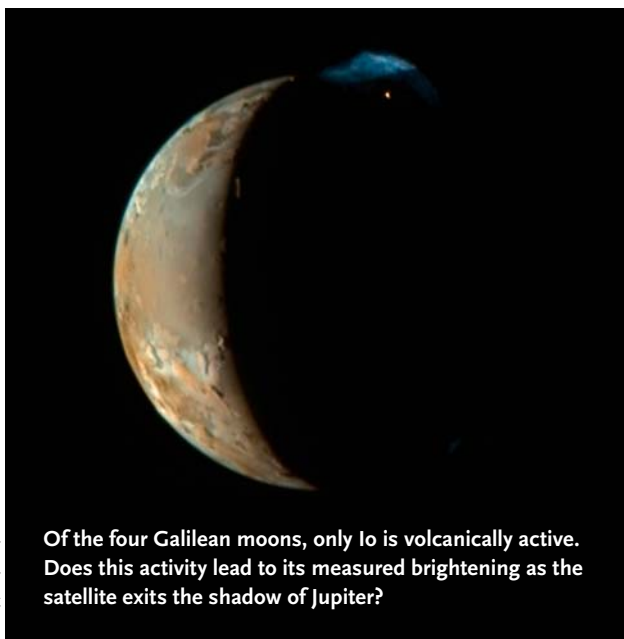

Of the four Galilean moons, only Io is volcanically active. Does this activity lead to its measured brightening as the satellite exits the shadow of Jupiter?

NASA / JHU / APL / SEAN WALKER

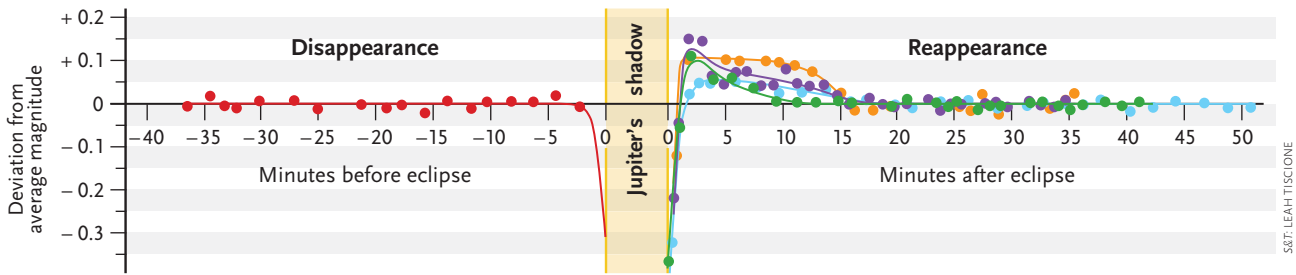

Photometric measurements of Io recorded by Dale Cruikshank and Alan Binder in 1962–63 using a 16-inch telescope recorded a subtle brightening following several eclipses. Although no brightness fluctuations were recorded before each disappearance (left), measurable brightness increases were recorded in four different observations immediately following the reappearance of the moon (right).

The sulfur dioxide gas that powers Io’s volcanoes was immediately recognized as the mystery component of Io’s atmosphere proposed by Cruikshank to account for Io’s post-eclipse brightening. The condensation and sublimation of sulfur dioxide frost provided a very convincing explanation for the fact that the phenomenon was not always observed. The amount of sulfur dioxide available would depend on the level of volcanic activity, which can vary dramatically on a time scale of days or even hours.

Although spacecraft observations all but eliminate the effects of scattered light from Jupiter, careful photometric monitoring of Io during a few eclipse events by the Voyager and Galileo spacecraft failed to detect any post-eclipse brightenings. However, during its flyby of Jupiter while en route to Saturn late in 2000, the Cassini spacecraft recorded a 15% increase in the reflectivity of Io in near-infrared wavelengths as the satellite emerged from Jupiter’s shadow, accompanied by a 25% increase in the intensity of the spectral absorption bands of sulfur dioxide frost.

Despite this confirming spacecraft observation, doubts persist that the condensation and sublimation of sulfur

dioxide is entirely responsible for post-eclipse brightening. Sulfur dioxide just doesn’t seem to be present in sufficient quantities to form frost deposits of adequate optical thickness (several millimeters by most estimates) except in localized areas. Emissions triggered by the interaction of Jupiter’s magnetosphere and Io’s tenuous but variable atmosphere have been proposed as an explanation by more than one investigator.

Io passes behind Jupiter once during every one of its roughly 42.5-hour orbits around the planet, so eclipses are not rare by any means (see the diagram on page 52). The best time to watch for these brightening events is following opposition, when the moon exits Jupiter’s shadow at an increasing distance from the planet’s limb.



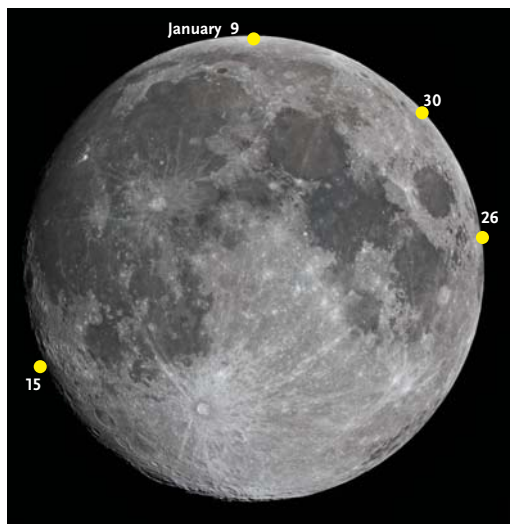

In recent years, well-equipped amateur astronomers have made remarkably accurate photometric measurements of phenomena far more delicate than the post-eclipse brightening of Io, notably the transits of extrasolar planets. Io’s post-eclipse brightening is a promising subject to monitor and study, one of those increasingly rare opportunities to solve a lingering observational mystery. ♦



S&T: DENNIS DI CICCO

The Moon • January 2015

Phases

-  **FULL MOON**
January 5, 4:53 UT
-  **LAST QUARTER**
January 13, 9:46 UT
-  **NEW MOON**
January 20, 13:14 UT
-  **FIRST QUARTER**
January 27, 4:48 UT

For key dates, yellow dots indicate which part of the Moon’s limb is tipped the most toward Earth by libration under favorable illumination.

Distances

- Apogee** January 9, 18^h UT
251,909 miles diam. 29’ 29”
- Perigee** January 21, 20^h UT
223,473 miles diam. 33’ 14”

Librations

- Sylvester (crater)** January 9
- Mare Orientale** January 15
- Mare Marginis** January 26
- Lacus Spei** January 30

The Fire Down Below

Lacaille's furnace glows with winter wonders.

At the November 15, 1754 meeting of the Académie Royale des Sciences, Nicolas-Louis de Lacaille presented a report of his scientific expedition to the Cape of Good Hope and a beautiful map of the southern skies painted by his friend Anne-Louise Le Jeuneux. Now displayed in the Paris Observatory's Grande Galerie, this chart boasts several constellations devised by Lacaille, including Fornax, which represents a chemist's furnace.

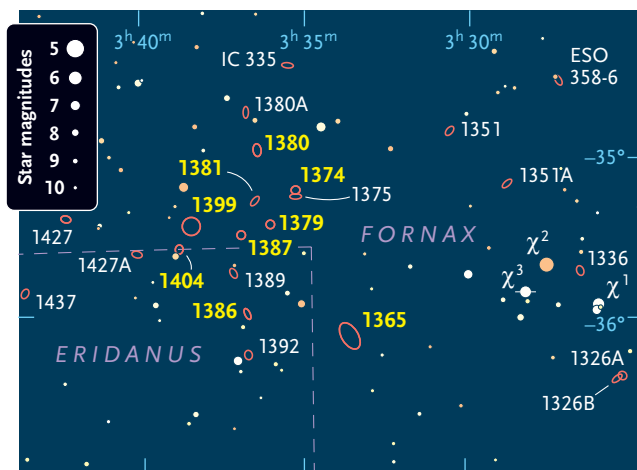

The Furnace burns well below the familiar stomping grounds of most northern skygazers, yet the treasures that blaze within it are visible even from my latitude of 43° north. And they're assuredly worth a look-see from observing locations farther south.

Fornax is largely populated with galaxies, but it also holds one large, impressive planetary nebula. **NGC 1360** bedecks the northeastern corner of the constellation, and the stars Alpha (α) and Beta (β) Fornacis point toward it. Even at 17× through my 105-mm refractor, the nebula is easily spotted as an oval glow tilted north-northeast. The 11.3-magnitude central star is weakly visible, but it shows up much better at 47×, with a dimmer patch nearby. The variable star **RZ Fornacis** is an eye-catching, reddish-orange gem perched 16.8' northwest of NGC 1360. It has a visual range of about 8th to 9th magnitude and a semi-regular period of 65 days. A narrowband or O III filter helps the nebula stand out better against the sky, but the central star appears faint with the former and disappears altogether with the latter. NGC 1360 is a superb sight through my 10-inch reflector at 70×. It covers roughly 6½' × 3½' and is brighter in its northern and western reaches.

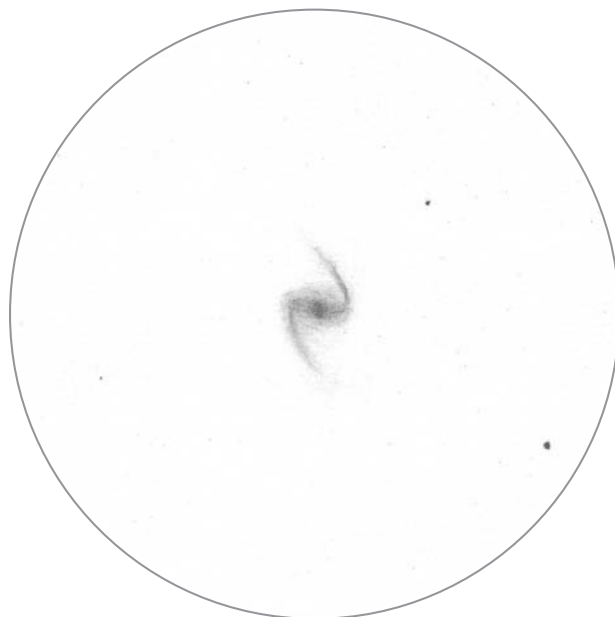
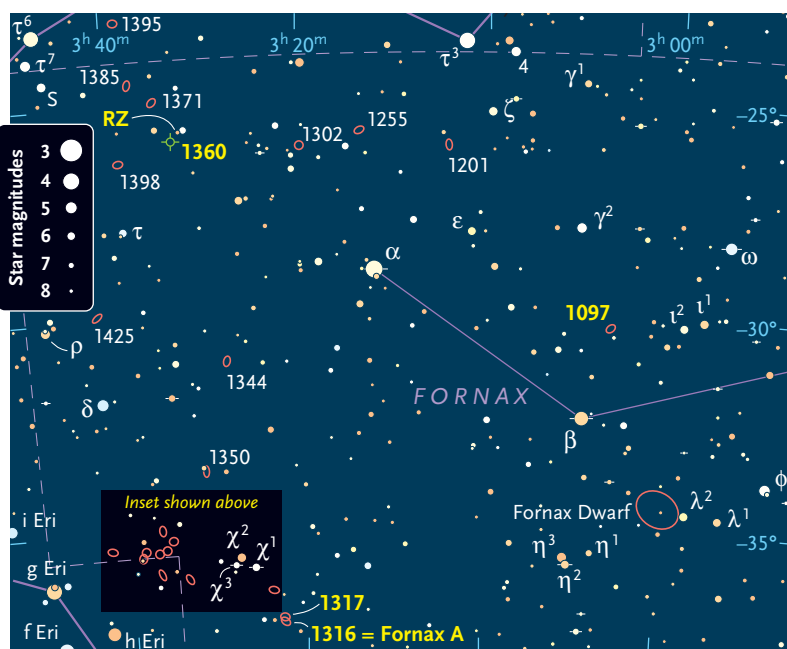

The author sketched the extreme barred spiral NGC 1365 as seen in her 10-inch reflector at 90×.

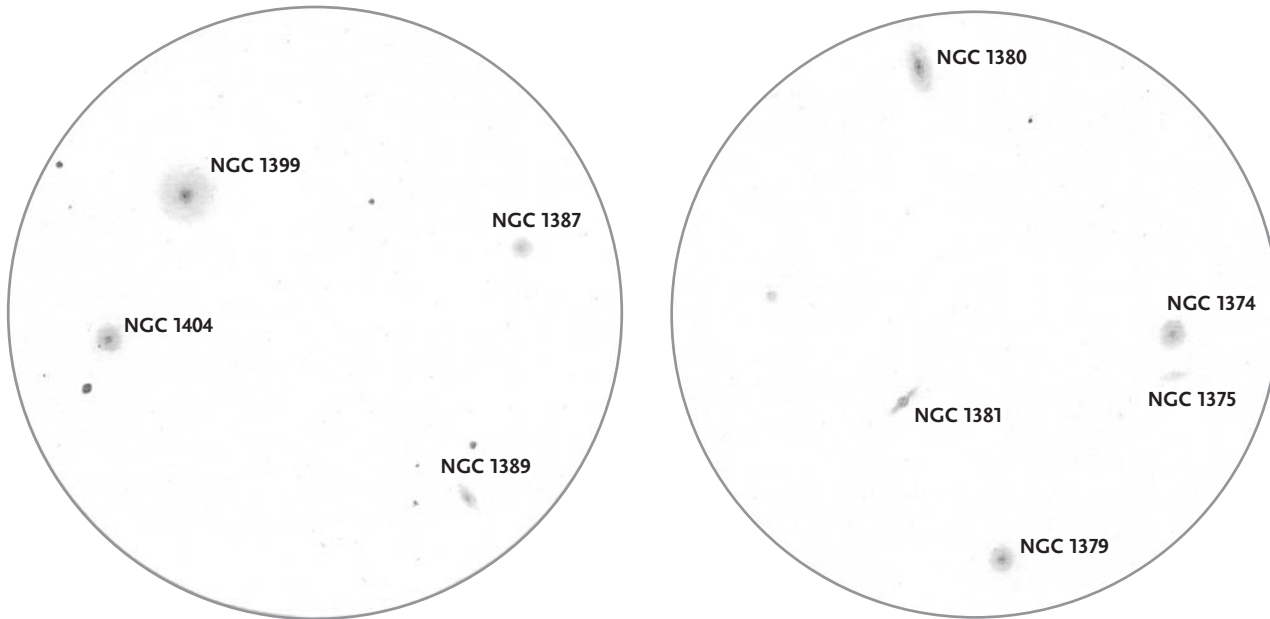

The author sketched two Fornax Galaxy Cluster fields as seen through her 10-inch reflector at 90x.

At approximately 10,000 years old, NGC 1360 is elderly for a planetary nebula. In a 2004 *Astronomical Journal* paper, Daniel Goldman and colleagues argue that the nebula has an ellipsoidal shell whose density falls toward the center, but has no sharp inner edge. The diffuse outer edge of the shell suggests that the nebula is starting to blend into the interstellar medium. The dim patches in NGC 1360 may indicate regions of low density or obscuring material within the nebula.

Lewis Swift described his discovery of NGC 1360 in the March 1885 issue of *The Sidereal Messenger*. While searching Eridanus for comets with his 4½-inch Henry Fitz refractor in 1859, he encountered a “most conspicuous nebulous star visible from this latitude.” He assumed “this wonderful object” must be well known, until he saw that it wasn’t included in John Herschel’s 1864 *General Catalogue of Nebulae and Clusters of Stars*.

The brightest galaxy in the northern half of Fornax is the giant barred spiral **NGC 1097**. It’s located 2.2° north-northwest of Beta Fornacis and due east of a 1.7°-long “dipper” of nine stars. This small grouping includes Iota¹ (ι¹) and Iota² Fornacis, and attracts attention through my 9×50 finderscope.

In my 105-mm scope at 17×, NGC 1097 is a small but easily visible oval of light, accompanied by a 5′ triangle of stars (magnitudes 8, 9, and 10) 13½′ to its south-southwest. At 47× the oval wears an ashen fringe and a small bright center. It’s about 4′ long and half as wide, tipped southeast. In my 10-inch scope at 90×, the galaxy’s interacting companion, **NGC 1097A**, makes an appearance as a petite spot just off NGC 1097’s northwestern tip. NGC

1097 is perhaps 5½′ × 3′, with a vivid little core and subtle, starlike nucleus. The companion is much more obvious at 118×, and NGC 1097 shows spiral arms unfurling counter-clockwise from each tip of the oval. NGC 1097’s core now seems slightly oval as well.

NGC 1097 is a Seyfert galaxy bearing an active nucleus whose prodigious energy output is powered by a voracious, central black hole with 100 million times the mass of our Sun. Images show that NGC 1097 is strikingly distorted by its elliptical companion. These gravitational dance partners dwell 46 million light-years away from us.

Another galaxy that reveals a spiral structure is **NGC 1365**, prosaically nicknamed the Great Barred Spiral Galaxy. Look for it 1.2° east-southeast of a prominent diamond of several stars, including Chi¹ (χ¹), Chi², and Chi³ Fornacis.

In my 105-mm refractor at 47×, NGC 1365 is a large

Selected Deep-Sky Objects in Fornax

Object	Type	Mag(v)	Size/Sep	RA	Dec.
NGC 1360	Planetary nebula	9.4	11.0′ × 7.5′	3 ^h 33.3 ^m	−25° 52′
NGC 1097	Spiral galaxy	9.5	9.3′ × 6.3′	2 ^h 46.3 ^m	−30° 16′
NGC 1365	Spiral galaxy	9.6	11.2′ × 6.5′	3 ^h 33.6 ^m	−36° 08′
NGC 1316	Lenticular galaxy	8.5	12.0′ × 8.5′	3 ^h 22.7 ^m	−37° 13′

Angular sizes and separations are from recent catalogs. Visually, an object’s size is often smaller than the cataloged value and varies according to the aperture and magnification of the viewing instrument. Right ascension and declination are for equinox 2000.0.

and modestly bright east-west glow with a fairly bright core and subtle projections at each end that give it a Z shape. The galaxy is quite beautiful through my 10-inch reflector at 90×, its graceful arms are admired more readily. From tip to tip (north-south), they span about 6' on the sky. A magnification of 115× further enhances these fetching features.

NGC 1365 is generally thought to be a member of the **Fornax Galaxy Cluster**, about 60 million light-years away from us. Unlike most galaxy clusters, the Fornax group embraces many members that can be enjoyed with small telescopes.

When viewed through my 4.5-inch tabletop reflector equipped with a wide-angle eyepiece that gives the scope a true field of 2.2° and a magnification of 35×, NGC 1365 shares the field with eight fainter Fornax Cluster galaxies. **NGC 1399** is the second-brightest galaxy in the

field of view. It looks roundish and about half the size of NGC 1365, with a brighter core and starlike nucleus. To the south-southeast of NGC 1399, **NGC 1404** presents a somewhat smaller, round glow guarded by a gold, 8th-magnitude star near its south-southeastern edge. **NGC 1380** is the third-brightest resident of the field. It exhibits an oval profile whose length is about two-thirds the apparent diameter of NGC 1399, and it envelops a relatively large, brighter core and starlike nucleus.

A zigzag chain of dimmer galaxies cuts across the triangle formed by the four galaxies described above. Working our way from north to south, I see a single smudge that's probably just **NGC 1374**, but it might be the combined glow of this galaxy and its close neighbor to the south, **NGC 1375**. **NGC 1381** is a tiny spot, perhaps elongated. Both looking like misty globes, **NGC 1379** gently intensifies toward the center, whereas **NGC 1387** hosts a starlike nucleus. The final field galaxy is **NGC 1386**, a small oval that leans north-northeast.

I sketched NGC 1365 and two Fornax Cluster fields of view as seen through my 10-inch reflector at 90×. The sketches are all done at the same scale. NGC 1386 isn't in either of the drawn fields, but in the 10-inch scope it's a nicely elongated galaxy, shaped much like a double-convex lens about 2½' long. At 118× it grows brighter toward a tiny nucleus.

Farther afield, yet still part of the Fornax Cluster, **NGC 1316** is the group's brightest galaxy. As one of the strongest sources of radio waves in our sky, it's also known as Fornax A. If you place Chi¹ Fornacis in the eastern edge of a low-power field and scan 1.3° southward, you'll come to a 15' right triangle of 7th- to 9th-magnitude stars, one at each corner, and a fourth along the hypotenuse. Fornax A is easily spotted to the triangle's west.

Through the 4.5-inch reflector at 14×, NGC 1316 is little but bright, and contains a brilliant center. At 64× the galaxy is oval northeast-southwest and sports a tiny nucleus, while a neighbor galaxy to the north now makes an appearance. **NGC 1317** is fainter, considerably smaller, and only slightly oval. It harbors a brighter core and an elusive stellar nucleus. In my 10-inch scope at 118×, NGC 1316 is about 4' long and perhaps two-thirds as wide, with a 13th-magnitude star off its southwestern end. NGC 1317's halo is about 1½' across, engulfing a small, slightly oval core that runs south-southeast to north-northwest.

Fornax A's two immense radio-emitting lobes span more than a million light-years. They're probably the result of a galactic collision that rained material onto Fornax A's central black hole, triggering oppositely directed jets of high-energy particles that heat the rarefied gas of intergalactic space. ♦



The giant barrel spiral galaxy NGC 1097 is distorted by the gravity of small but bright NGC 1097a.

KITT PEAK NATIONAL OBSERVATORY

Tucson, Arizona

- Public Programs for Amateur Astronomers
- Advanced Observing Program
- Image Que Data Gathering

Astrophotography Workshops 2015:

Beginners

May 22-24 / October 16-17

Advanced

November 6-7

THE KITT PEAK EXPERIENCE...
LIKE NO OTHER

For information www.noao.edu or 520.318.8726

TAKAHASHI



INTRODUCING THE NEW AND IMPROVED FSQ-106ED

- Color correction extended to 1000 nm for sharper stars
- Rotatable fine-focuser handles large CCD cameras (to 5-kg)
- 4-element ED Petzval optics render superior images
- Smaller tube length (16.7") for easy airline transport

New stand-alone GoTo controller for our Temma mounts. See website for details.



Texas Nautical Repair, Inc., 1925A Richmond Avenue, Houston, Texas 77098
Phone: 713-529-3551 • Fax: 713-529-3108 • www.takahashiamerica.com

TelescopeS.NET

by Woodland Hills Camera & Telescopes



LX850
Built-in guiding
for imaging



CGE Pro 1400 HD
Your ultimate
portable 14" scope



Why wait for your favorite CDK
when you can have one now?



While supplies last!

Canon
EOS 60Da DSLR
Astrophotography Camera



100 degree
eyepieces
for as
little as
\$249



Special Closeout

Sphinx SXD
w/tripod
Regular: \$2,899
Now \$1,495!
While supplies last



SkyTracker
w/Polar Scope
Easy setup,
Excellent
performance
\$399



888-427-8766 Intl: 818-347-2270 • 5348 Topanga Canyon Boulevard, Woodland Hills, CA 91364

Flawed Giants



ROBERT
ZIMMERMAN

The world's largest optical telescopes have had to overcome serious hurdles, delaying their scientific success.



R. CERISOLA / LBT

UNDER SCRUTINY Face down, a secondary mirror for the Large Binocular Telescope is checked in the lab. The 672 tiny magnets spread over the mirror's backside deform the surface to compensate for atmospheric effects. The upper portion contains the devices that control the magnets.

FOR THE LAST TWO DECADES the world's astronomers — and *S&T* readers — have been tantalized by the construction of one new record-breaking ground-based telescope after another. Each was heralded as the telescope of the future, able to outperform the Hubble Space Telescope, peer into the distant past to solve the mysteries of dark matter and dark energy, and reveal the puzzles of stellar evolution and the formation of planetary systems.

Yet, as each one neared completion, the publicity and news coverage would slowly peter out. Years would pass without any game-changing scientific discoveries coming from these leviathans.

What had happened? We decided to find out, and what we learned is that these telescopes are far more difficult to build than their press releases have suggested.

“These are huge industrial machines,” explains Gerard van Belle (Lowell Observatory), one of several instrument architects involved in the effort to combine the two 10-meter Keck telescopes in Hawaii into a single giant interferometer — until the interferometry project was shuttered in 2012. “It is like playing Whac-A-Mole. You fix one problem, and another pops up somewhere else.”

These sobering facts hold a warning for the much-touted next generation of even larger telescopes: things might not turn out as rosy as *their* press releases suggest.

Too Much of a Good Thing

In the last three decades the field of ground-based astronomy has undergone a revolution of design and construction. Beginning with the first-generation design of the Multiple Mirror Telescope (MMT) in 1979, astronomy has seen a plethora of new giant telescopes come online. The two Keck 10-meters in Hawaii, which saw first light in 1993 and 1996, proved that large-scale telescopes could be built and produce good science.

Keck was soon followed in 1996 by the 9.2-meter Hobby-Eberly Telescope (HET) in Texas, in 2005 by the 9.8-meter Southern African Large Telescope (SALT) in South Africa and the first of the two 8.4-meter mirrors of the Large Binocular Telescope in Arizona, and in 2008 by the 10.4-meter Gran Telescopio Canarias (GTC) in the Canary Islands.

These five observatories top the list of the world's biggest optical telescopes. Yet, only the Keck telescopes have not had significant technical and management issues, and even Keck has seen failure with its effort to turn its two telescopes into an interferometer.

The Keck Interferometer sounded like it had enormous potential, combining two 10-meter telescopes into a

single telescope with the resolution of an 85-meter mirror. For years the press releases from the Keck Observatory as well as from NASA raved about the possibilities. As Paul Swanson, project manager for the Keck Interferometer at JPL, said in 2001, “This is a major step in the creation of a whole new class of astronomical telescopes that will have an enormous impact on future knowledge.”

Ten years later, with the interferometer still not fully operational, NASA announced that it would no longer fund the project, and the observatory quietly shut the entire operation down.

The failure of this high-profile project was partly tech-

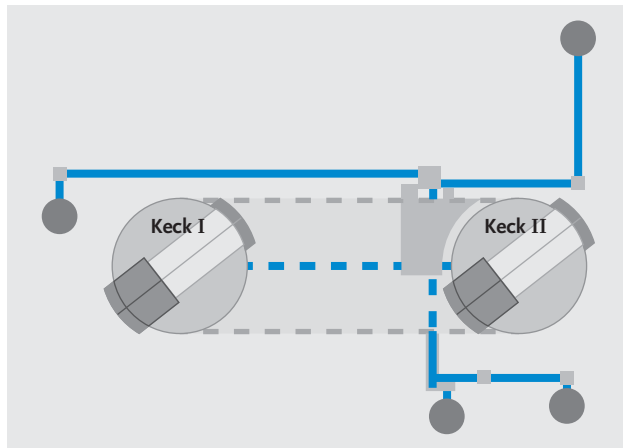

S&T: GREGG DINDERMAN



NASA / T. WYNN / JPL

TWIN EYES Keck I and II on Mauna Kea were designed to work in tandem with four smaller scopes as an interferometer (top). Although NASA ultimately canceled the interferometry project, the two 10-meter telescopes remain powerhouses in optical and near-infrared astronomy, producing exceptional science.



JOHN GOOD



THOMAS A. SEBRING / HET CONSORTIUM

FACE LIFT In Operation Chrome Dome, engineers at the Hobby-Eberly Telescope resurfaced the entire dome with aluminum tape. The aluminum reduced the dome's radiative cooling at night, improving seeing.

BIG BONES HET's structure dwarfs most telescopes — and people. Seated at HET's base are the then-director and associate director of McDonald Observatory.

nical but mostly political. In order for images from the two Keck 10-meter telescopes to be properly combined, it was necessary to build and install at least four smaller, 1.8-meter “outrigger” telescopes in an array surrounding the two 10-meter telescopes.

These additional telescopes, however, were initially opposed by members of the native Hawaii population who consider Mauna Kea sacred. They were also opposed by environmentalists, who, even after local Hawaiians gave a green light to the outriggers (*S&T*: Aug. 2001, p. 40), filed suit against NASA and the University of Hawaii to demand an environmental impact assessment before construction continued.

Then the outrigger funding dried up in 2006. NASA had paid for the interferometer, along with similar research at LBT, as support for two planned space telescopes aimed at hunting for exoplanets: the Space Interferometry Mission and the Terrestrial Planet Finder. But in 2006 NASA tabled TPF and cut funding for the outriggers; in 2010 it also decided not to sponsor SIM. With both of these missions canceled, and with Keck continuing to face legal and logistical problems, NASA decided to cut its support, essentially ending the project.

Fortunately, this shutdown had little impact on the overall success of the Keck Observatory. Its two 10-meter telescopes remain functional and among astronomy's best success stories.

The world's other giant telescopes, however, have not fared so well.

SALT in the Wound

The Southern African Large Telescope (SALT) was going to put South African astronomy on the map. In order to build a world-class telescope on a limited budget, its builders decided to utilize the design of the Hobby-Eberly Telescope (HET) in Texas.

HET's 9.2-meter effective aperture is the world's fifth largest, but the telescope itself cost only \$16 million to

build, a fraction of the cost spent on the other giants. To save money, the telescope's mirror of 91 hexagonal segments was mounted on a rotating platform at a fixed zenith angle of 35°. Operators could rotate it but not tilt it. Instead, the instrument package, mounted on a frame above the mirror at its focal point, would move, tracking objects as their reflection traveled across the mirror's face.

In addition, the mirror segments were not parabolashaped but spherical. The design limits the effective aperture, meaning that HET doesn't use its primary's full 11 meters. This curve also does not produce very sharp images, but it is far easier to build, as every segment can be identical. Because of this, the telescope was optimized for spectroscopy, which doesn't need pretty pictures.

Unfortunately, HET experienced serious focusing and resolution problems right from the beginning and which lasted for years. “When we came on sky it was immediately obvious that we were making terrible images and we couldn't hold them,” explained Gary Hill (McDonald Observatory, University of Texas at Austin).

The coatings on the segments deteriorated more rapidly than expected. The temperature in the telescope's dome was too hot, causing mirror distortions. The 91 segments were difficult to align, and even once finally aligned they would lose that alignment quickly.

It took about a decade to work out these bugs. The effort included major upgrades to the dome, to the sensing equipment that monitored and positioned the segments, and to the instruments themselves. Engineers applied new coatings to the segments and established a more thorough and regular cleaning regimen for the segments.

Even these efforts did not make HET the instrument its builders had originally hoped it would be. Thus, in 2009 McDonald Observatory decided to do a major rebuild of the telescope and a significant revamping of its fundamental research effort. Rather than make HET an all-purpose spectroscopic observatory, they would treat it like a NASA astronomical probe similar to the Kepler

discovery-class mission, with a specific, single research goal and instruments designed for that goal.

The goal chosen is dark energy. By installing the world's largest collection of multi-object spectrographs and increasing the telescope's field of view — to about half the area of the full Moon — they hope to compile a gigantic database of the redshifts of a million galaxies from about 11 billion years ago. When these data are compared with other similar surveys covering different cosmic epochs, HET's scientists hope they will be able to better quantify the universe's expansion rate and how dark energy has caused it to change over time.

This \$40 million overhaul — more than twice the telescope's initial cost — is just wrapping up. The telescope will begin three years of observations aimed solely at this single research objective. Hopefully this approach will allow HET to finally produce science at the level dreamed of by its creators.

SALT, meanwhile, was completed in 2005, designed similarly to HET but with HET's known bugs eliminated. Unfortunately, there were the unknown bugs. For reasons that initially baffled its builders, the images SALT

produced would randomly range from perfect to horribly smudged. The situation became so serious that at one point Darragh O'Donoghue, the head of the effort to fix the telescope, bluntly noted at a technical conference in 2010 that “unless the problem is solved soon, the telescope will be seen as a failure.”

Fortunately, after several years of complex detective work the team pinpointed the focus problem. Because the curve of the telescope's mirror segments were like HET (spherical rather than parabolic), both telescopes' designers needed to correct images for spherical aberration. To do this, an instrument called the spherical aberration corrector (SAC) refocused the light coming off the mirror and then sent that light to the scientific instruments. The two telescopes' SACs had different optical designs (and therefore gave the scopes different effective apertures), but had the same purpose.

SALT's problem was that its SAC's steel frame was bolted to an aluminum ring, which in turn was glued into the carbon composite structure of the instrument payload. These three materials all expand differently when heated and contract differently when cooled. The

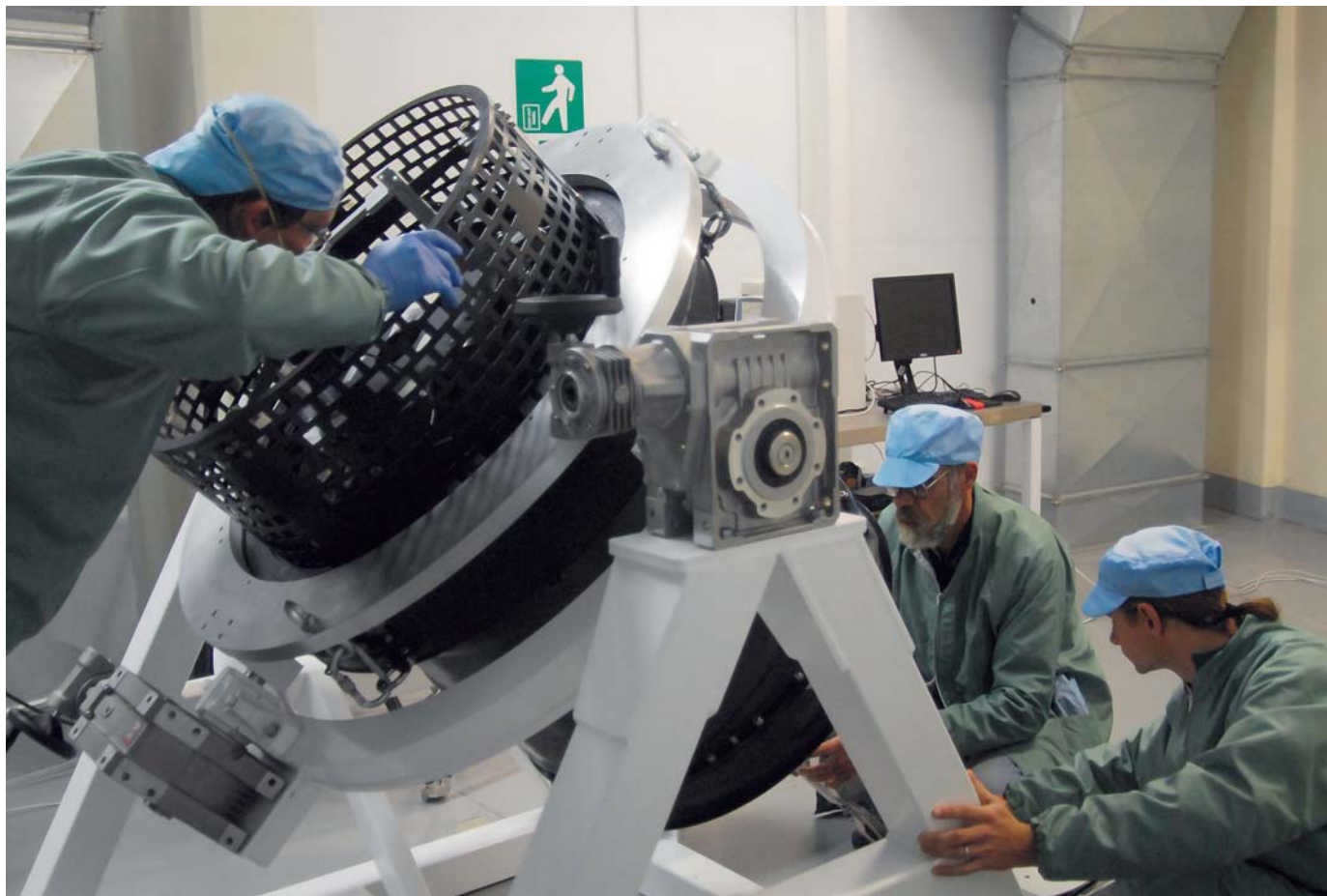

OPEN WIDE Members of SALT's image quality team prepare to test and realign the mirrors of the spherical aberration corrector (big tube). Stresses on the instrument had shifted the mirrors awry, producing images that were sometimes sharp and sometimes smudged (see next page).

combination introduced a gigantic amount of unwanted thermal and mechanical stress in the SAC, ruining its mirrors' alignment.

These repairs were only completed in 2010. Since then the telescope has been operating successfully, but time will tell if it will meet its specifications. For example, the telescope still lacks a working active-alignment system

BEFORE AND AFTER Stars imaged before the repair of SALT's spherical aberration corrector (left) look smudged. After the repair, the stars looked properly pointlike.

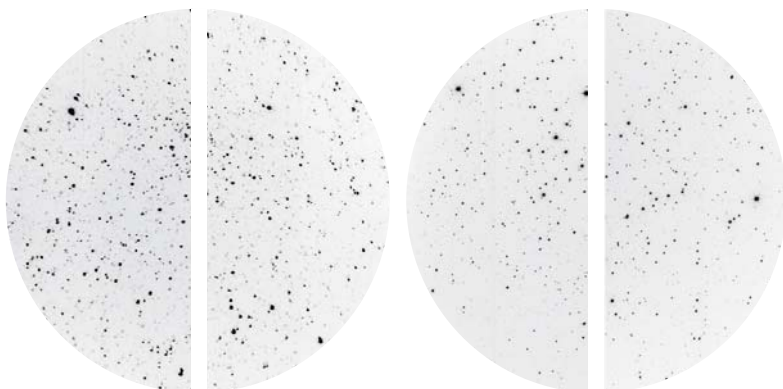

for its mirror segments, requiring operators to do manual alignment twice per night. This reduces observation time and also limits the length and precision of many of the telescope's observations.

Double Vision

Then there is the Large Binocular Telescope (LBT). First proposed almost three decades ago in 1986, the concept called for combining the light from two 8.4-meter mirrors mounted side-by-side like a gigantic pair of binoculars to produce the equivalent light-gathering power of a 11.8-meter mirror and the resolution of one more than 22 meters across.

Construction was delayed almost a decade because of objections by environmentalists and the local Apache Indians. The environmentalists were worried about the telescope's effect on the endangered red squirrel that lives on the mountaintop of Mount Graham, while the Apaches said the mountaintop was sacred and therefore should have no new construction. It took a special exemption passed by Congress and a lot of wrangling to get the construction finally approved.

Then, once construction began in 1996, it took far longer than expected. As with the other large telescopes, there were engineering issues. For example, in order



STARGAZING GIANTS *Left:* Seen here in 2005 are SALT's dome and alignment system (tower in foreground). *Right:* The Large Binocular Telescope houses two primary mirrors in its boxy structure. Both LBT and SALT faced significant delays, but they are both up and running.

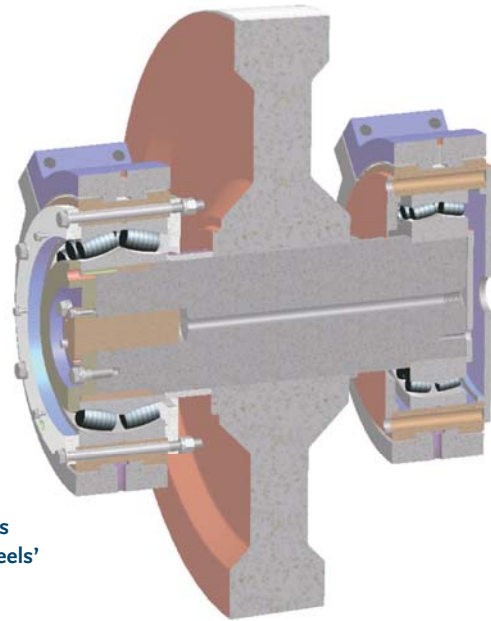
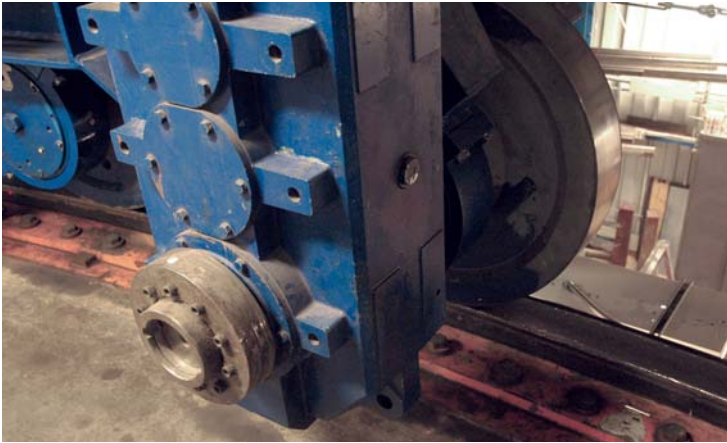

BEARING WOES In order to make LBT's bogies follow a circular track, engineers tilted the wheels 2.5° from the vertical. But this tilt put too much force on the wheels' outer bearings. Engineers cut the old outer bearings out and replaced them with larger ones (shown in the left side of the schematic).

for the telescope to view the entire sky, the building that houses it, weighing 2,200 tons, rotates on four multi-wheeled units called bogies that roll on a circular track. Construction engineers soon found significant engineering problems with this system. The rail the bogies ran on was wearing out faster than expected. Moreover, one

wheel's outer bearing had failed, and all the other wheels' outer bearings were on the verge of failure, requiring their complete replacement.

Engineers also learned that one bogie was slightly offline. (Imagine one of the rear wheels of your car pointing sideways slightly, rather than straight ahead.) To get it realigned required jacking the entire 2,200-ton building up slightly so that they could force it back into the correct position, silencing its popping and banging noises.

The telescope itself had other problems. For example, the telescope's instruments are moved into position at the end of deployable swing arms. The use of these arms allowed the operators to switch out different instruments easily during an observing run. Unfortunately, the arms had difficulty damping out vibrations caused by wind and other disturbances.

In addition, the oil and grease used on the giant track that tilted the telescope would get sprayed onto the mirrors when the telescope's ventilation fans turned on. Keeping the fans off eliminated this spray, but that made it difficult to stabilize the telescope's temperature for observations.

But all these technical engineering problems were relatively routine issues: they are the typical shakeout problems experienced by giant telescopes. What really delayed LBT from producing the expected science after first light in 2005 was the late arrival of almost all of its scientific instruments, which because LBT is a binocular telescope, come in pairs.

For example, the second of the telescope's two optical spectrographs, the Multi-Object Double Spectrographs (MODS), was only installed on the telescope in the spring of 2014, almost a half-decade late. "The MODS team had never built anything this big before," explained Christian Veillet, LBT's director. "I think they underestimated the time and challenges required."

Similarly, the telescope's two infrared spectrographic

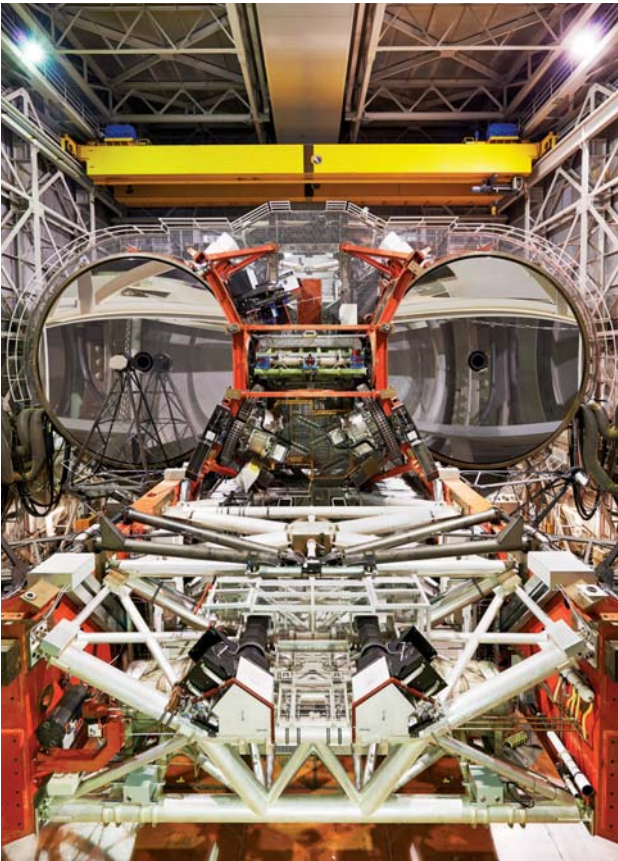

BIG BUG Two 8.4-meter primary mirrors combine to create the alien-looking binocular telescope.

cameras, called LUCI 1 and LUCI 2, arrived in 2010 and 2013, years behind schedule. “I think the scope of the project and its complexity was once again underestimated,” says Veillet. “The team also did not have much experience building this kind of cryogenic instrument.”

It was only in 2014 that all of LBT’s first-generation instruments were finally installed on the telescope. They are currently in commissioning phase and should be available for science users by mid-2015. Although science has already been coming out of LBT (*S&T*: July 2012, p. 18), project members now hope that the telescope’s scientific output will finally ramp up to its expected level.

Part of the reason these instruments were so late was the chaotic management structure that formerly existed at LBT. Financed and built by partners in the U.S., Germany, and Italy, the telescope had no strong central management authority. For example, the partners were each in charge of building their own scientific instruments, with the observatory having little say in their design. “We don’t know anything about them,” explains Veillet. “They arrive as black boxes.”

Because of all these issues the telescope partnership decided in 2013 to hire Veillet as director and gave him the authority to manage the telescope properly. As one sci-

entist told me at the first LBT users’ meeting, organized in March 2014 by Veillet in Tucson, Arizona, “Things are much better now with Veillet.”

Big Bird

Lastly there is the Gran Telescopio Canarias (GTC), on La Palma in the Canary Islands. The world’s largest parabolic telescope, with an effective aperture of 10.4 meters, the GTC was only completed in 2008, making it the youngest of this generation of giant telescopes. Thus, it is finishing out the initial shakeout period expected for all such big telescopes, lasting on average four to six years.

In the case of GTC, most of its problems have centered on maintaining the proper temperatures for two of the telescope’s main instruments.

Soon after commissioning in 2008, telescope engineers found that the CCD of the telescope’s main optical camera, OSIRIS, was much warmer than planned. In order for the camera to detect objects with magnitudes as faint as 28 in a reasonable amount of observing time,

BIG BIRD Like its giant brethren, the Gran Telescopio Canarias dwarfs people. With an effective aperture of 10.4 meters, GTC is one of the largest optical telescopes in the world.

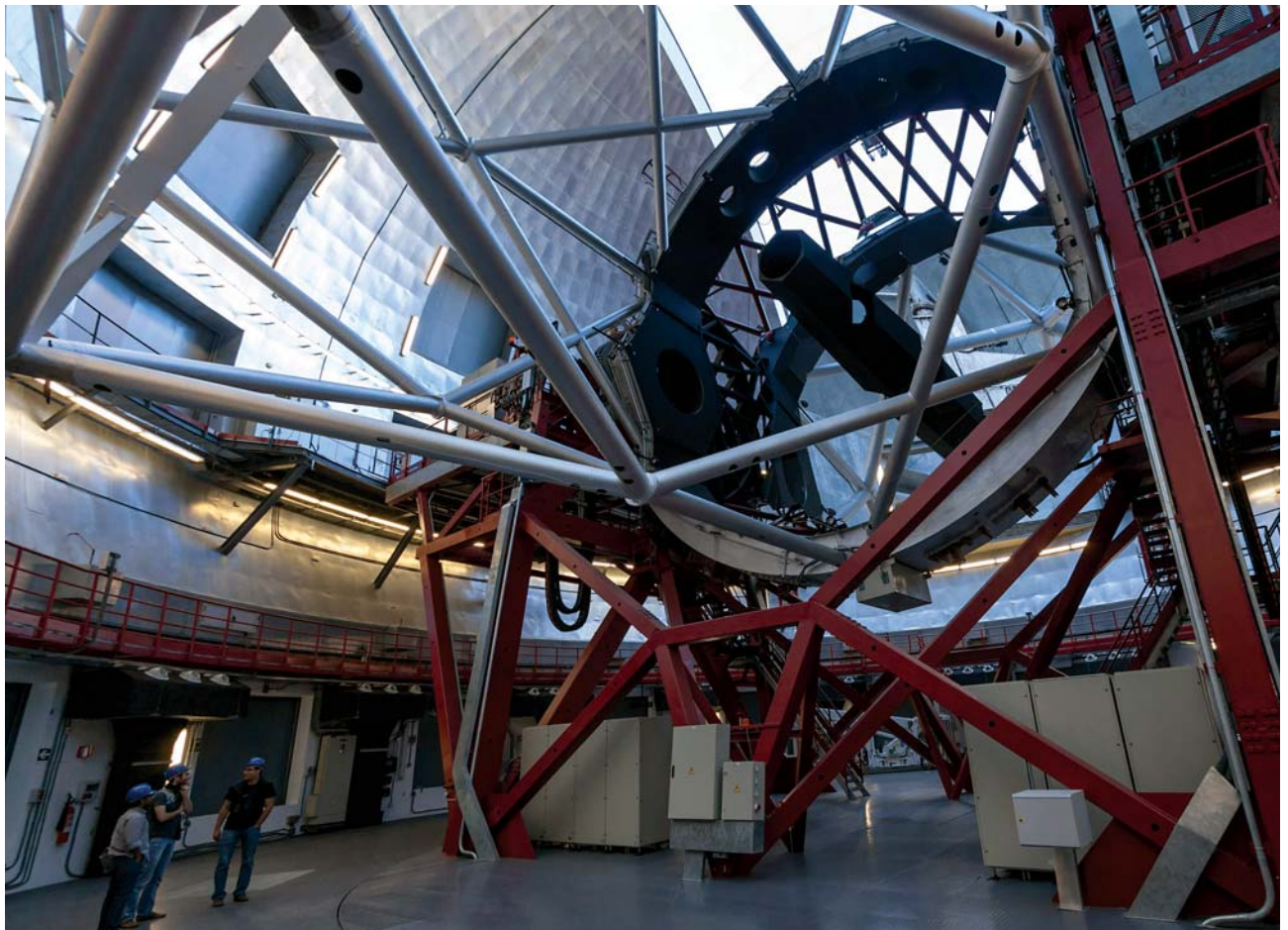

BABAK TAFRESHI



BABAK TAHERSHI

ABOVE THE CLOUDS The Gran Telescopio Canarias sits on the island of La Palma in the Canary Islands. It is still in its initial shakeout phase but is producing science results.

the CCD must be cooled to 170 kelvin so that its own heat doesn't drown out the object's signal.

The problem was that the dewar, the cryogen flask designed to cool the CCD, wasn't doing the job. As the telescope's website notes, the system required "continuous baby-sitting to ensure that temperature and pressure remained within operational bounds."

To fix the problem, the observatory first built a temporary dewar to replace the one that was not working. When this was installed in 2010, the problem improved. The original cryostat was taken apart, where it was discovered that heat was being conducted from the outside world into the CCD at three contact points. Once engineers replaced the stainless steel contacts with insulation, the dewar was finally able to function correctly.

Then in 2013 a similar problem occurred with the telescope's infrared instrument, CanariCam. In this case the system for cooling the instrument, called a cold head, was supposed to have a life expectancy of one year. "In practice the cold head wouldn't survive in operating conditions more than five months, sometimes not more than two months," explains Pedro Álvarez Martín, GTC's director. "The provider has been unable to correct the problem."

A permanent fix will require replacing the system entirely. In the meantime the observatory has obtained a number of spares and switches them out when necessary. "We live with a heavy load on our operations team," adds Martín. "Each CanariCam service requires a week of instrument down time."

On top of these engineering issues the telescope has had the typical start-up funding problems. Because of 2009 cuts to the science budget in Spain, the telescope's biggest partner, the observatory was forced to stretch out development of the telescope's second-generation instruments, producing "a considerable slippage in our initial plans," according to Martín.

With these initial shakeout problems now under control or solved, GTC's scientific output should begin to ramp up to more expected levels in the next few years.

The Future

What do these stories tell us about the next generation of giant ground-based telescopes like the Giant Magellan Telescope (GMT), the Thirty Meter Telescope (TMT), and the European Extremely Large Telescope (E-ELT), which are now in their initial design or construction phases? Will their future be the same, with similar difficulties?

The history here suggests yes. All these telescopes have faced similar problems. For example, the present generation of big telescopes all began their lives with either very tight or insufficient budgets, or some form of budget cuts. None had sufficient funding to keep instruments' builders on staff during the transition to operations so that they could train the operations staff properly. "The amount of funding never quite insures a long enough overlap," notes Hill. "This is a lesson that the big future telescopes had better be careful about."

Sometimes only a little more money was needed to fix things. For example, engineers built HET for \$16 million, but to straighten out its worst problems only cost another \$4 million.

Other times, however, the completion costs have been vastly higher. Even with HET, designers eventually decided that the \$4 million repairs were insufficient, opting for a complete \$40 million overhaul. The worst examples of this kind of cost overrun have been seen with space telescopes, including both the Hubble Space Telescope and the upcoming James Webb Space Telescope. There, the overruns were so large that at some point both projects were threatened with shutdown.

Thus, no one should be surprised if the next generation of giant ground-based telescopes — the E-ELT, the TMT, and the GMT — have serious growth pains. Each might take several years of trial and error before it can produce sharp images and begin churning out the really spectacular astronomical discoveries.

These telescopes, however, will be on the ground and accessible for redesign and repair. The one terrifying thought that kept reappearing in my conversations with engineers and astronomers is, what will happen if Webb requires the same kind of shakeout? Located a million miles from Earth, it might develop problems engineers haven't weeded out in their zealous tests, and the most expensive telescope ever built might end up becoming nothing more than a hunk of metal, useless to anyone.

But however easy the accessibility to scopes on the ground, the engineers and managers of the giants of the future will likely still find themselves scrambling about madly, "whacking moles" as they struggle to get their telescopes up and running. ♦

Contributing editor **Robert Zimmerman's** classic history of the 1960s space race, *Genesis: The Story of Apollo 8*, is now available as an eBook. When he isn't visiting giant telescopes, he writes daily at <http://behindtheblack.com>.



Oltion's Awesome Binoscope

This fine instrument was a highlight at the 2014 Oregon Star Party.

BINOCULAR TELESCOPES are one of those ideas that sound great, yet rarely seem to work out in practice. Everyone appreciates the rewards of astronomy with regular binoculars, so it's easy to imagine how amazing it would be to scale up the aperture and magnification. And yet, binocular telescopes remain rare novelties. That's because they're not easy to make, and the difficulty runs deeper than the work involved in making twin optical tube assemblies. Oregon telescope-maker Jerry Oltion was up for the challenge. "I decided early on to go for simple and strong," he says. That approach led him to "think inside the box." The optics reside in two boxes, one housing two 12.5-inch-diameter, f/4.7 primary mirrors, the other supporting dual upper-cage assemblies.

One of the challenging aspects of a binocular telescope is making a mechanism that allows a range of interpupillary spacings. Jerry's "simple and strong" system consists of twin rotating secondary cages. As the assemblies rotate in tandem, the spacing between the focusers (and therefore, eyepieces) changes. "I made the cages with 1/2-inch plywood rings and doorskin for the panels," he explains.

Four sets of bolts and washers capture the bottom ring of each cage, allowing for rotation. The challenge was to



The spacing between eyepieces is governed by a mechanism built largely from a cargo-strap tightener purchased at a local hardware store.

precisely control that motion. But a trip to the hardware store yielded the solution. As Jerry explains, "The adjustment mechanism is a repurposed cargo-strap tightener that has a coarse-thread (8 threads per inch) screw that pulls and pushes a carriage along its length."

Careful readers will note that the "gotcha" in this scheme is the need to tweak the interpupillary spacing each time the scope is focused. But this turned out to be a minor issue. "The focusers sit between the secondary and the tertiary mirrors and move the eyepieces sideways, so focusing does change the spacing, but not by much," Jerry says. "I use parfocalizing rings to make all my eyepieces focus within a fraction of an inch of each other, so the amount of adjustment is minimal."

There's no denying that building a binoscope is a lot more work than making a regular Dobsonian. Is the extra effort worth it? "In a word, absolutely," Jerry reports. "I'd looked through other binocular scopes — up to 8-inch aperture — and knew the views could be really nice, but I wasn't prepared for how visually arresting the images delivered by two 12.5-inch mirrors turned out to be."

The binoscope works as well as a conventional 18-inch scope when it comes to detecting faint galaxies, but what really surprises Jerry is how it performs on solar-system targets such as the Moon. "Talk about a 3-D effect!"

I don't know about you, but that whets my appetite for a binoscope project. For more about Jerry's latest creation, visit www.sff.net/people/j.oltion/binoscope.htm. ♦



KATHY OLTION (2)

Jerry Oltion's binoscope is well built and delivers awe-inspiring views. A stool and adjustable chair provide a range of observing positions.

Contributing Editor **Gary Seronik** is an experienced telescope maker and binocular observer. You can contact him via his website, www.garyseronik.com.

Beautiful Planetary Globes

Mercury Globe

To create this dramatic portrayal, the editors of *Sky & Telescope* worked with Messenger scientists to produce the globe's custom base map. Produced in cooperation with NASA and the U.S. Geological Survey.

Item #MERCGLB \$99.95 plus shipping

Moon Globe

A beautiful and extremely accurate new globe of the Moon. This globe is a mosaic of digital photos taken in high resolution by NASA's Lunar Reconnaissance Orbiter.

Item #MOONGLB \$99.95 plus shipping

Topographic Moon Globe

The Topographic Moon Globe shows our home planet's constant companion in greater detail than ever before. Color-coded to highlight the dramatic differences in lunar elevations.

Item #TPMNGLB \$109.95 plus shipping

Mars Globe

Created from images taken by the Viking orbiters, our 12-inch globe approximates the planet's true color. Produced in cooperation with NASA and the U.S. Geological Survey.

Item #4676X \$99.95 plus shipping

Earth Globe

Showcasing Earth as a planetary body, this unique globe of our home planet is based on NASA satellite imagery and other data.

Coming later this year!

COMING SOON

SHOP at
SKY

888-253-0230 www.ShopatSky.com

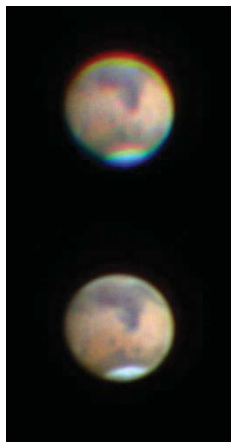

The Contrast Booster: ADC Compact

Why an APO, when never use it's full performance ?

Our **ADC Compact** restores completely the contrast loss caused by atmospheric dispersion !

 **optiksysteme
Gutekunst**



www.gutekunst-optiksysteme.com

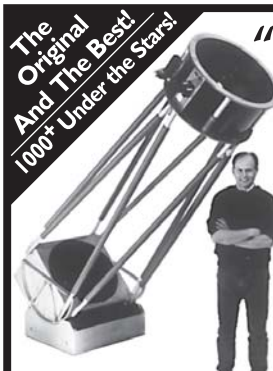

"9 Billion Light-Years!"

- Paul K., 22" UC, Hohe Dirn, Austria

*"My most distant object ever:
Quasar PG1634+706 in Draco."*

- Portable Alt-Az • Superb optics
- Ultra-smooth easy operation
- Exceptional craftsmanship
- A scope for every serious observer:
12" • 15" • 18" • 20" • 25" apertures

Send For the Obsession DVD & Brochure

**OBSESSION
TELESCOPES™**

PO Box 804s, Lake Mills, WI 53551 (920) 220-1195
www.obsessiontelescopes.com

**NEW UCs
Ultra Compact
15", 18", 22" - f/4.2**



See it on-line
Fits in any car

The 10" Astro-Tech truss-tube R-C is only \$2995!

A carbon fiber truss, quartz mirrors, dielectric optical coatings – every **Astro-Tech** true Ritchey-Chrétien reflector (even the 10") has premium features at a very non-premium price.

Ritchey-Chrétien astrographs are the choice of professional astronomers and observatories world-wide. For an affordable **Astro-Tech** R-C, visit our astronomics.com website, or give us a call.

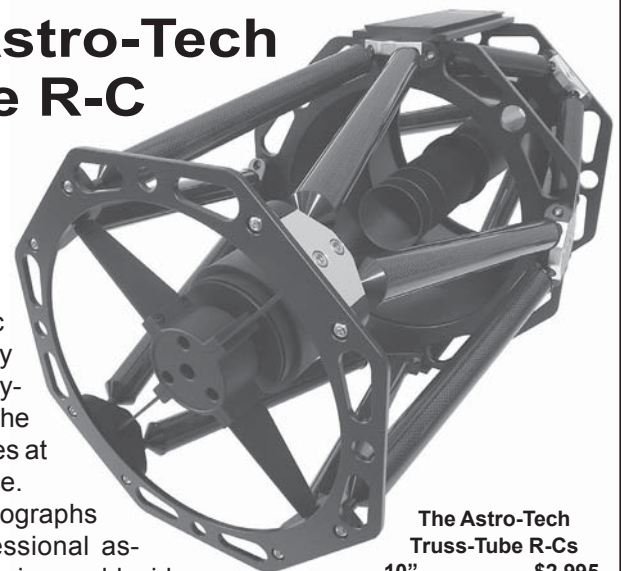

The Astro-Tech
Truss-Tube R-Cs

10"	\$2,995
12"	4,495
16"	6,995
20"	12,995

astronomics.com™

Telescopes • Binoculars • More

(800) 422-7876

Now in our 35th Year.

AstronomyTechnologies.com

CloudyNights.com

Composing the Universe



**Robert
Gendler**

Planning your composition can raise your imaging to a whole new level.



The art of deep-sky astrophotography differs from most other types of picture-making. Astro-imagers learn the fundamental techniques of combining many long exposures to suppress noise while simultaneously increasing the signal to reveal ever-fainter objects in their images. Tools such as calibration frames, pixel rejection methods, and tri-color technique are mostly unheard of in other types of photography.

But many fundamentals of photography remain the same whether your subject is a distant galaxy or a picturesque landscape. Color balance, contrast, and composition come into play in every great image, no matter the subject. As imagers strive to raise their work beyond the point of simple picture-taking, composition and visual aesthetics become important considerations in the journey to create a truly memorable photograph. Here are some ways to consider your next target — before opening the shutter — that can add drama and power to your compositions and set them apart from the crowd.

Zeroing in on the Focal Point

In order to push our images to that higher level, it's important to ask ourselves the question that artists throughout history have asked themselves: What do we want the viewer to concentrate on? This is the focal point of the picture, the main subject that inevitably draws the eye and commands the most attention.

When planning a composition, I often mentally divide the picture into three components — the focal point, supportive structures, and background. These elements may be obvious, such as a galaxy (the subject) surrounded by a few bright stars (supportive

A little planning can often go a long way. While photographs of the Orion Nebula complex are usually presented with North at the top, rotating the composition 180° combined with the tight framing of this composition places the bright nebula at top left while other supporting structures draw the viewer's eye around the entire image. All photos are courtesy of the author.

structures), and the background of dimmer stars in a sea of black. But they might also include less obvious divisions, particularly when shooting sprawling nebulae. We might designate the subject by increased brightness and contrast, for example, or by highly defined structures or color emphasis.

Subtle structures in the image have importance, too, but they play a supportive role in directing the viewer's journey to the natural focal point by way of visual or directional cues. By doing so the viewing experience becomes an orderly passage in which the elements within the image function like coordinates in a GPS, guiding the viewer in a logical and satisfying journey through the image.

Happily, most astronomical subjects have a natural focal point. Examples include the bright nuclei of galaxies or the brilliant young stars within bright nebulae such as the Trapezium within M42, the Orion Nebula. But interesting targets exist that lack a natural focal point, such as a nebulous field that stretches beyond your camera's field of view. In this situation it becomes your task to establish the focal point through creative framing of the scene, using the supporting structures to create the illusion of a natural focal point.

The focal point doesn't have to occupy the center of an image. Many fine examples exist of asymmetric focal points in successful astro-images. One caveat: if the focal point is off center, then a supporting structure needs to occupy the area opposite the focal point. This could be a smaller, more distant galaxy juxtaposed against the brighter and larger galaxy subject, or a fainter open cluster of stars. The key is to allow the main focal point dominance in the image through positioning, brightness, or selective sharpening.

Creating Visual Flow

When viewers examine an image for the first time, they need visual cues to lead them through it, as alluded to above. This process is known as "flow" — the subtle directing of a viewer's eye through an image.

Offering engaging flow is essential because as astro-photographers we work with static subjects. We're forced to utilize the existing elements of our chosen scene while working with the variables we do have control over, including light, color, scale, depth, and symmetry. We can use all these elements to enhance flow. Framing is also critical. Astronomical scenes often have supporting structures such as dust clouds, stars, or distant background galaxies, for example, that the photographer can frame in such a way as to create a sense of flow in an otherwise static image.

Striking a Balance

Proper balance is one of the most crucial compositional elements. As a rule, pleasing balance results from appropriate contrast between the focal point, supporting structures, and the background. A group of bright stars framed



Above: The Trapezium star cluster in the center of M42 is the natural focal point in this photo captured by NASA's Hubble Space Telescope. The original composition was rotated 90° clockwise so that the blue giant stars along the left side as well as the sharp bow shock at left produce a visual flow that leads to the central focal point in the image.

Below: A pleasing composition was achieved in this image of M17, the Swan Nebula, by taking advantage of the natural flow of the brighter areas of the nebula when the field is presented South-up to draw the viewer's eye from the lower left to upper right. Often astronomical images achieve their strongest visual impact when the image is composed with the subject in mind rather than the cardinal points of the compass.





The original landscape framing (left) of the star-forming region NGC 6188 in Ara lacks drama. Rotating the composition 90° counter-clockwise and cropping to a square format creates a more appealing scene with a clear focal point that takes advantage of the natural axis of the dominant structures in the image.

along one side of an image, for example, can serve as an important directional cue, leading the eye to the focal point and helping to establish a dramatic composition.

On the other hand, while colorful star fields can be striking, if stellar intensities are too strong they can detract from an image's focal point and supporting structures. Imagers sometimes use several tools to suppress the intensity of stars in an image, including the minimum filter and the spherize tool in *Adobe Photoshop*. These tools are best applied selectively and sparingly to only those stars that detract from the focal point.

Depth of Field

One challenge in astronomical image-processing is creating the perception of three dimensions in a two-dimensional image. Often the highest praise for a stunning astrophoto is that it conveys a sense of depth and perspective.

If the focal point of an image has greater detail, color intensity, or contrast compared with the supporting structures, the viewer is given the perception of depth. Some targets, particularly when shooting a tight close-up within a large nebula or dense star-field, may require additional processing to impose that coveted sense of depth.

Selective sharpening of key areas in an image full of bright and dark nebulae can often add a vivid sense of depth to an image. To enable the viewer's eye to zero in on the subject quickly, you can leave regions within your photo "softer" than the area you've designated as the focal point. A similar approach works well when imaging galaxy clusters or star clouds within the Milky Way.

Complementary Colors

Color composition can also be integral to the success of an astrophoto. When shot in natural color, astronomi-

cal objects tend to display a limited palette of blues, reds, yellows, and blacks. A glance at a color wheel will reveal that certain colors have greater appeal when they appear opposite their complementary color. The bluish reflection nebulae that often appear adjacent to reddish emission nebulosity within the plane of the Milky Way, for instance, can contribute to a pleasing composition. Knowing the hues of objects in advance can often help you to create stimulating color contrast.

Astrophotographers working with narrowband filters have more leeway to take advantage of complementary color schemes, because they can assign each narrowband image to a different color channel to achieve dramatically different results than imagers working in RGB color.



This mosaic was composed using the "rule of thirds" by positioning NGC 2070 at the intersection point of a grid dividing the image into 9 sections. Smaller nebulae serving as supporting structures throughout the field help to balance the composition.

Format Decisions

One of the simplest but most important processing decisions is how to manage the aspect ratio of your image. Should you present the image in landscape or portrait mode, or as a square? This choice can have profound effects on the visual impact of an image.

You'll want to ask yourself: what is the dominant axis of the structures in the image? If objects tend to run along the horizontal axis, then a landscape format will likely be in harmony with those structures and offer a more appealing viewing experience. A composition with mostly vertical structures will benefit most from a portrait composition. And fields in which the long axis runs diagonally or targets a well-centered, round focal point will likely present best in either square or nearly square format. Whatever orientation you choose, try not to fight the natural dominant axis of the object.

When I complete an image, I often experiment liberally with cropping — shrinking a field of view around a small galaxy, say, or getting rid of distracting secondary structures — as well as rotating the image to find the most appealing presentation. In astronomical imaging, one cannot change his or her viewpoint to the object, but managing the scene by way of framing, cropping, and rotating can produce some spectacular results.

Rules, Rules, Rules

In traditional photography the well-known rule of thirds and its variations are helpful guidelines for composing a picture. The rule of thirds suggests that when planning a composition, the photographer should divide the image into a grid of nine equal parts by mentally placing two equally spaced horizontal and vertical lines over the field. The photographer should then position salient compositional elements at the four points of intersection.

This compositional strategy produces a visual storyline with energy, direction, and flow accentuated by a more intriguing off-centered focal point. Significant structures need not fall precisely on the points of intersection to take advantage of this rule. Astronomical objects that benefit most from the rule of thirds are C- or U-shaped nebulae, galaxy clusters, and complex star-forming regions with juxtaposed star clusters and nebulae.

Composing Panoramas

One of the most daunting tasks in astrophotography is producing effective wide-field panoramas. By their nature they are exclusively mosaics, so you have greater opportunities to plan the composition and position key objects and focal points in advance.

Because of the extreme aspect ratio of panoramas, they often require some deviation from the standard compositional rules. The rule of thirds or a single focal point — mainstays for non-panoramic images — do not always work with positioning vital objects and structures within



Top: In this image of NGC 5033, the long axis of the galaxy is composed as a vertical axis, which robs this horizontal composition of any tension. **Above:** By rotating the image 45° counter-clockwise and cropping to a nearly square format, the axes of the galaxy, along with the bright star at bottom left, engage viewers by allowing them to read the image along the natural flow beginning at the lower left.

an astronomical panorama. You might position key objects or main focal points of the vista within the center third of the image, for instance, with supporting structures and background elements filling the outer thirds.

In sum, composing astronomical scenes can be challenging due to the limitations of photographing static celestial objects from our fixed viewpoint. But taking time to carefully plan the composition before beginning the first exposure can make the difference between an adequate image and a timeless treasure. ♦

Learn more imaging techniques in author **Robert Gendler's** latest book *Lessons from the Masters: Current Concepts in Astronomical Image Processing*, from which this article was adapted.

ECLIPSE • MARCH 2016

INDONESIA, MARCH 1-17, 2016



<http://InsightCruises.com/Sky-7>



SKY
& TELESCOPE

Sail roundtrip Singapore on Holland America Line's Volendam with Sky & Telescope's Bob Naeye, Australian Sky & Telescope editor Greg Bryant, and astronomers Dr. David Tholen and Dr. E.C. Krupp on the eclipse trip of a lifetime.

Join the fun and experience legendary Indonesia's cultures. You can explore Komodo, Bali, Lombok, UNESCO sites, and traditional cuisines all in the company of fellow eclipse buffs. When it's time to capture eclipse memories, tap Sky & Telescope's expertise. Reserve now for best cabin selection as this sailing is guaranteed to sell out.

While the full eclipse cruise is 16 days if you wish you can join the group after the initial Singapore departure and leave the cruise early, in Bali, spending as few as nine (9) days onboard.



Cruise prices vary from \$1,999 for an interior stateroom to \$8,299 for a Neptune Suite, per person, based on double occupancy. (Plus gov't taxes and fees, \$329; booking service fee, \$100; cruiseline gratuities, \$11.50 per day; and Tour Leader gratuities, \$100. For those attending our Program, there is a \$1,075 fee. (The Program fee includes eclipse-viewing glasses, 13 seminars, a planetary debate, Q&As, and several receptions.) **Book by October 1st and save \$300 per person on the Program fee.** For full terms and conditions please visit: InsightCruises.com/Sky-7



Robert Naeye has been Sky & Telescope's Editor in Chief since 2008. Previously he was Senior Editor at Sky & Telescope and Senior Science

Writer for the Astrophysics Science Division of NASA's Goddard Space Flight Center. Robert is the author of two books: *Through the Eyes of Hubble: The Birth, Life, and Violent Death of Stars* and *Signals from Space: The Chandra X-ray Observatory*.



Dr. E.C. Krupp is an astronomer and Director of Griffith Observatory in Los Angeles. He received his M.A. and Ph.D. in astronomy at UCLA,

where he studied the properties of rich clusters of galaxies as a student of Professor George O. Abell. He started his career at Griffith Observatory in 1970. Dr. Krupp has personally visited, studied, and photographed more than 2,000 ancient, historic, and prehistoric sites throughout the world and has led or supported 13 total solar eclipse expeditions and four annular eclipse efforts.

For more info: 650-644-5812 or Info@InsightCruises.com



Greg Bryant has been Editor of *Australian Sky & Telescope* since 2006 and a Contributing Editor to *Sky & Telescope* since 2001. He has also been involved with the publication of an

Australian annual astronomy yearbook since the early '90s and science writing for the Australian Research Council's Centre of Excellence for All-Sky Astrophysics. A keen amateur astronomer for more than 30 years, Greg most recently teamed up with Insight Cruises for their successful 2012 Total Solar Eclipse tour in Australia. In 2000, the International Astronomical Union named asteroid 9984 Gregbryant in his honor.



David Tholen, Ph.D. is an astronomer at the Institute for Astronomy of the University of Hawaii (IfA), who specializes in planetary and solar system astronomy. Winner of the American Astronomical Society Division for Planetary Science's Urey Prize in 1990, Dr. Tholen and his students have discovered many near-Earth asteroids, the most famous being Apophis, which will make an extremely close approach to the Earth on April 13, 2029.

CST# 2065380-40

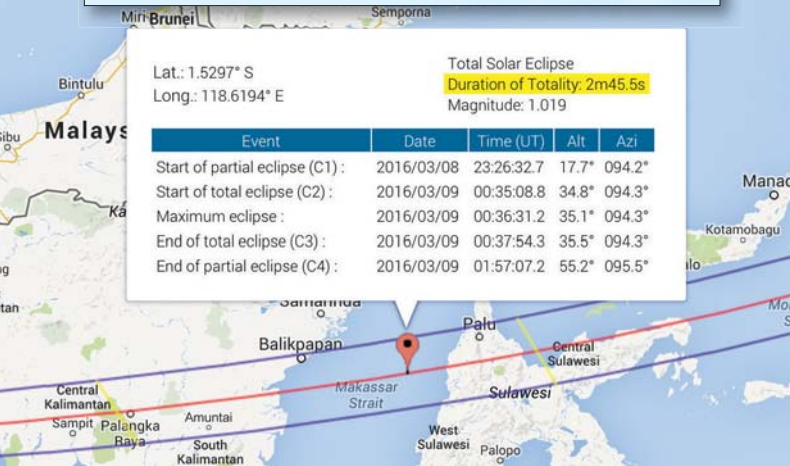

Add eight (8) hours to UT time for local time. I.e., the start of the total eclipse (C2) will be 8:35am.

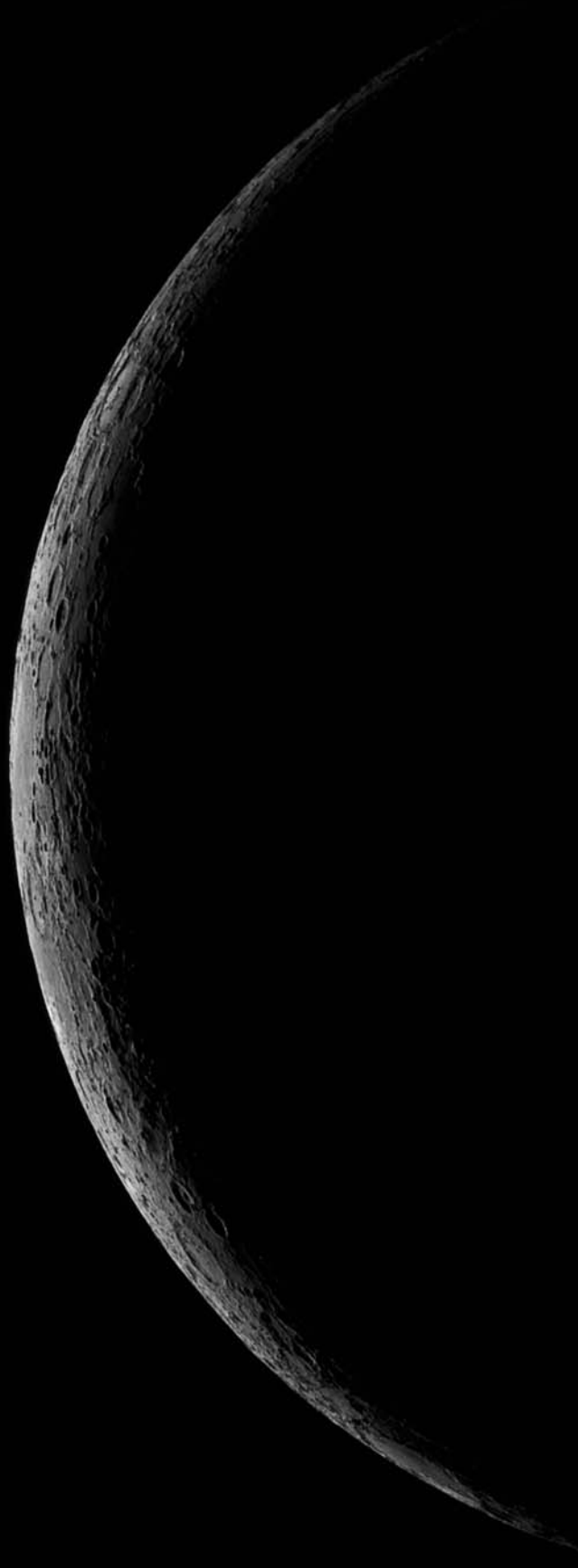

SLIVER OF THE MOON

Helder Jacinto

This exquisitely detailed image of the young crescent Moon presents numerous features not often seen in low light conditions, including the flooded basin known today as Mare Humboldtianum at lower left. South is up in this photo.

Details: Orion EON 120-mm ED refractor with Imaging Source DMK 41AU04.AS video camera. Mosaic of four images, each a stack of 1,600 video frames.

SUNSPOT

Leo Aerts

Picturesque sunspot AR 12146 displays long, thin flux tubes within the penumbra while hundreds of granules dot the surrounding photosphere.

Details: Celestron C14 Schmidt-Cassegrain reflector with an Imaging Source DMK 31AU03.AS video camera. Stack of multiple video frames recorded through a Baader Planetarium AstroSolar Safety Film and a red filter.

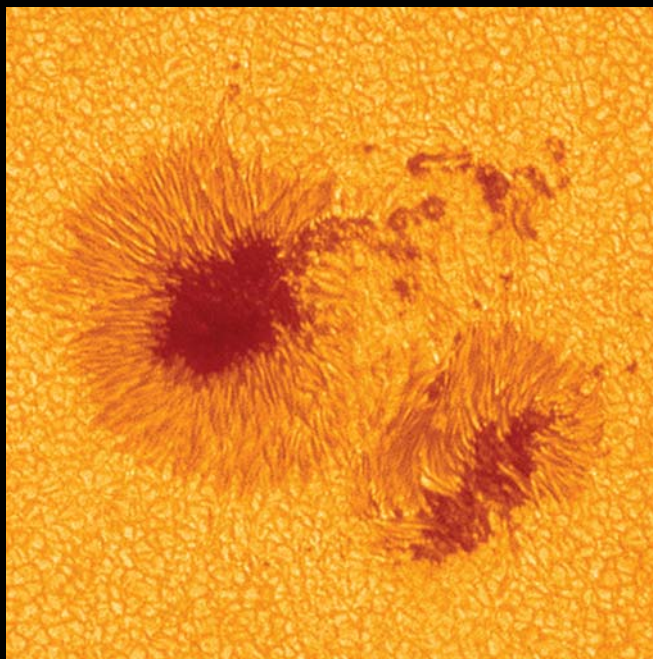





Visit SkyandTelescope.com
/gallery for more of our
readers' astrophotos.

◀ TWO TAILS OF PANSTARRS

Gerald Rhemann

As comet C/2012 K1 PanSTARRS neared its peak brightness this past September, it sported the lumpy bluish ion tail of gas streaming off to the right in this photo, while its diffuse dust tail curved off towards the left.

Details: ASA12N-OK3 f/3.8 astrograph with FLI MicroLine ML8300 CCD camera. Total exposure was 52 minutes through color filters recorded in Namibia, Africa, on the evening of September 21, 2014.

▼ PANORAMIC STAR TRAILS

Vince Farnsworth

The stars of the Northern sky appear to circle around Polaris at center, as seen above the Black Canyon of the Gunnison National Park in Colorado, U.S.

Details: Canon EOS 5D Mark II DSLR with 17-to-40-mm zoom lens at f/16. Mosaic of eight images, each exposed for 30 minutes.





▲ **NEBULOUS WOMB**

Ron Brecher

Open cluster NGC 6823 in Vulpecula appears enveloped by the reddish emission nebula NGC 6820. Intense ultraviolet radiation from the newborn stars in the cluster is slowly eroding the surrounding nebulosity.

Details: ASA10N-OK3 astrograph with SBIG STL-11000M CCD camera. Total exposure was 13½ hours through Baader color and hydrogen-alpha filters.

► **SHARPLESS IN CEPHEUS**

Michael Keith

The faint star-forming region in Cepheus called Sharpless 2-132 is sometimes known as the Dragon Nebula. (Do you see it?)

Details: Borg 60ED refractor with Atik 460EX CCD camera. Total exposure was 5 hours through color and narrowband filters. ◆

Gallery showcases the finest astronomical images submitted to us by our readers. Send your very best shots to gallery@SkyandTelescope.com. We pay \$50 for each published photo. See SkyandTelescope.com/aboutsky/guidelines.





FOCUS ON Sola Fide Observatory – Austin, Minnesota

The **ASH-DOME** pictured is a 12'6"-diameter, electrically operated unit. The observatory dome shelters a 10-inch, f/10 Dobbin's telescope. The observatory is used for personal observing and by local amateur astronomy groups year-round.

ASH MANUFACTURING COMPANY
P.O. Box 312, Plainfield, IL, USA 60544
815-436-9403 • FAX 815-436-1032

www.ashdome.com
Email: customerservice@ashdome.com



Ash-Dome is recognized internationally by major astronomical groups, amateurs, universities, colleges, and secondary and primary schools for its performance, durability, and dependability. Manual or electrically operated units in sizes from 8 to 30 feet in diameter available. Brochures and specifications upon request.

Art, Science, & Observation

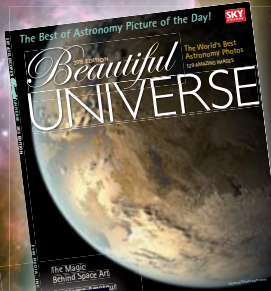

Beautiful Universe is an annual showcase of many of the most incredible images being taken by amateur and professional astronomers.

SkyWatch is the yearly astronomy guide from *Sky & Telescope* with maps and guides so clear that even beginners will be able to use them. **SkyWatch** tells you how to choose and use a telescope, photograph the sky, and so much more.

Beautiful Universe 2015

USA \$9.99

Canada \$12.99

SkyWatch 2015

USA \$8.99

Canada \$9.99

Get your copy of each today to make sure you see all the wonders of the night sky!

Available on newsstands or online at
ShopatSky.com or call toll free: **888-253-0230**

SHOP
at
SKY

Image of Butterfly Nebula: NASA / JPLA / Hubble Servicing Mission 4 (EPO Team)

Sell Your Used Equipment For Free!



FREE AD LISTINGS FOR INDIVIDUALS

As an individual selling your own personal gear, you can place an ad online at MarketPlace free of charge — and it will remain in place for up to 12 months or until the product sells.

FREE ALERTS

If you are looking for something specific, register to receive e-mail alerts when new ad listings appear that match your saved search criteria. Registering to enjoy this feature is simple —and free.



SKY
& TELESCOPE **Online**
MarketPlace

SkyandTelescope.com/marketplace



Market Place

Your essential source for astronomical products

ACCESSORIES



Bob's Knobs
Meade, Celestron, Intes, Takahashi ... and more!
6976 Kempton Rd.
Centerville IN 47330
765-855-5109 USA
www.bobsknobs.com

VariMax Eyepiece Projection Adapters



New to our Pro-Series lineup of camera adapters. Accepts eyepieces up to 2.5" in diameter. Features a laser engraved extension scale, interchangeable nose-pieces and more! Only \$129!

2" UltraWide Prime Focus Adapters



Offers 10mm More Clear Aperture than a T-Ring!

The Pro-Series also includes our True-2 Prime Focus adapter. This 2" Ultrawide adapter eliminates vignetting caused by using restrictive T-Rings. From \$69!



Digi-Kit "Point & Shoot" Adapters from \$44.95



T-Rings T-Caps
T-Mounts
T-Extensions

Fast \$8 Shipping!



Expert Advice!

SCAN HERE



Visit our Site!

Use Discount Code "S&T" for 10% off!

www.TelescopeAdapters.com

ACCESSORIES



Now Build your own custom adapter at

www.preciseparts.com

305 253-5707
info@preciseparts.com

PRECISEPARTS
CUSTOM PARTS FOR ASTRONOMY

New Seletek Tarsier



Most advanced *autonomous* digital focusing system

- Stepper or d.c. motors
- Can perform automatic temperature compensation
 - LCD screen - Totally configurable
 - Saves focus "goto" points

Launch price \$145, shipping included
Get it now from lunaticastronomical.com

AAG CloudWatcher (\$495): your observatory safeguard, now with optional wind speed meter.

More info: www.lunaticastro.com

Howie Glatter's Laser Collimators & Accessories
tuBlug™ and Blug™ Barlowed collimation aids
SkyPointers™ & brackets - Glatter Mirror Sling kits



The Parallizer™

2"-1.25" adapter for Perfect Parallel Alignment
Howie Glatter 3850 Sedgwick Ave. Bronx, N.Y. 10463
Tel/Fax (718) 796 3203

www.skypointer.net www.collimator.com
e-mail: howieglatter@mindspring.com

ACCESSORIES

MEADE SCT UPGRADES

For focus, clutch, drives, light thru-put, mounting, carrying & balancing.



EZ BINOC MOUNT KIT

Outdoor mount handles all size binoculars. View standing, sitting or reclining. \$106.95

PETERSON ENGINEERING

www.petersonengineering.com 401-245-4068

Robo-Focus™ Digital Focusing

- * Precision focus control via PC
- * Autofocus capability
- * Full manual operation as needed
- * Temperature compensated
- * Automatic backlash correction
- * Remote power outlet box (option)
- * Fits most scopes & focusers

\$475

See www.homedome.com for details

TECHNICAL INNOVATIONS
407-601-1975 domepage@erols.com
"RoboFocus is a gem!"

Advertise in **Marketplace**



LESTER STOCKMAN
PHONE: 617.758.0253
ads@skyandtelescope.com

ACCESSORIES

Foster Systems

Serving astronomers and observatories worldwide

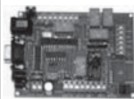

Roll off Roof & Dome Controllers

- ASCOM compliant interface
- Automatic or Manual ops.
- Power monitoring and mgt.
- Weather monitor integration
- Dew Management

From \$247
With Software

Visit us at www.fostersystems.com

BOOKS

FROM WILLMANN-BELL
Get full details
at willbell.com
\$34.95

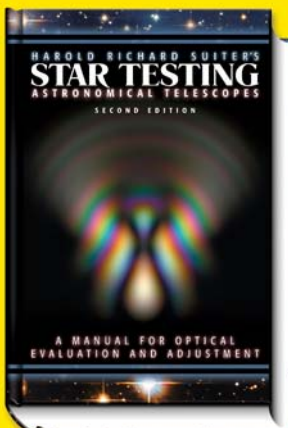

COMPUTER SOFTWARE

Deep-Sky Planner 6

Comprehensive planning
& logging software

www.knightware.biz



OBSERVATORIES / DOMES

**DURANGO SKIES
OBSERVATORY SOLUTIONS**

Consulting & Project Management
site plan design & review |
equipment configuration |

Observatory & Equipment Sales
domes |
roll-off roof plans |
telescopes |
mounts & piers |

Installation & Training
assembly supervision |
install & test equipment |
operational & maintenance training |

www.observatorysolutions.com

OBSERVATORIES / DOMES

**HOME-DOME AND PRO-DOME
OBSERVATORIES**



PROFESSIONAL DESIGN — AMATEUR PRICE

- ★ 6', 10' and 15' Diameter
- ★ Stand-alone or On Building
- ★ All Fiberglass
- ★ Easy Assembly
- ★ Manual/Computer Automated
- ★ Full Height/Handicap Access
- ★ Priced from \$3,295

CloudWatcher
Low cost, accurate
system to detect
cloud cover, light levels
and first traces of rain.
With DDW interface.
www.cloudetection.com



Call or write for a FREE Brochure

TECHNICAL INNOVATIONS

Phone: (407) 601-1975 www.homedome.com

ORGANIZATIONS

only you
can save
the night

www.darksky.org

OPTICS



Optical Coatings
Parabolic Mirrors
Testing
Refiguring

www.OpticWaveLabs.com

❁ Nova Optical Systems ❁

Optical Coatings up to 20"
www.nova-optical.com

Email sdodds@nova-optical.com
(801) 446-1802



www.ShopatSky.com

MOUNTS

**Alt-Az Mounts and Tripods
"NO BALANCE REQUIRED"**

- *Extremely Rigid
- *Silky Smooth even at 300 power
- *Change eyepieces without re-balancing
- *Designed from the start to use DSCs
(no external cables or encoders)
- *No counter weights
or locks
- *Quality at it's best



DiscMounts, Inc
HANDCRAFTED BY TOM PETERS

www.DiscMounts.com

954.475.8574

**Equatorial Fork Mounts
Observatory German Mounts**



With over 34 years of
experience, we offer mounts
that provide the size, stability,
and precision for serious
astronomical observation.

mathis-instruments.com

925-838-1487

TELESCOPES

The House of Orthoscopies

The finest in Japanese oculars for those seeking
exquisite lunar and planetary detail

University Optics Inc. • Box 1205
Ann Arbor, MI 48106

universityoptics.com • 734.663.2542

JMI telescopes, cases, telescope dollies, focusers, mirrors, and LOTS more!!

Telescopes - 12" to 40"
Bino-Scopes - 6" to 16"
Motofocus - 250 models
Carrying Cases

Wheelybars for Moving Scopes
Max Guiding Computers
Microfocus & T-N-T tracking

Click on our **RED TAG SPECIALS!**
Black Friday Nov. 27 - Dec. 7



Jim is now 77, looking for an investor and/or working partner.
Call him: 303-717-3345

Jim's Mobile, Inc.

JimsMobile.com

303-233-5353 Tel • 303-233-5359 Fax

ASTRO-PHYSICS

Dedicated to
Craftsmanship!

New!!!
1100GTO

Portability &
Capacity
Absolute Encoder
Option

**HOT
PRODUCT
2014
SKY
& TELESCOPE**



www.astro-physics.com

Machesney Park, IL USA
Ph: 815-282-1513

**FASTEN
YOUR
SEATBELT**



STELLARVUE'S FLAGSHIP
THE SV160 APO TRIPLET
PARAMOUNT MX
THE ULTIMATE SYSTEM
MADE IN THE U.S.A.

MILKY WAY AT THE SV DARK SKY STAR PARTY BY TONY HALLAS



STELLARVUE®

WWW.STELLARVUE.COM

SEEING IS BELIEVING

11820 KEMPER ROAD

AUBURN, CA 95603

(530) 823-7796

MAIL@STELLARVUE.COM

PlaneWave
INSTRUMENTS

Planewave.com

- CDK Astrographs
- Mounts
- Observatory Systems

Background Image by Don Goldman

**Explore
Saturn**

with Our Newest App



Download on the
App Store

Join us and expect
the extraordinary.

2015

SOUTHERN SKY

- Costa Rica -

TOTAL ECLIPSE

- Svalbard -

- Faroe Islands -

AURORA & CULTURE

- Norway -

2016

TOTAL ECLIPSE

- Bali New Year -

- Indonesia & Borneo Cruise -

TRAVELQUEST
international

TravelQuestTours.com

1 800 830-1998

Sky & Telescope's
SkyWeek
PLUS



Available on the
App Store

FOR SALE: Orion EON 120-mm f/7.5 ED Refractor OTA, aluminum case, tube rings, excellent condition. \$1,200. 218-262-5114 (Minnesota).

DOS CABEZAS, ARIZONA: Astronomy Home-Land. Elev. 5000 ft. 32 deg lat. Only \$65K. Totally remodeled small stucco home on .4 acres. Clean, modern, move-in ready. Very dark, transparent locale with good seeing. Private well, fenced, gated, secure. Paved access. 20 min SE from Willcox, AZ (Pizza Hut, Safeway). 90 min from Tucson. Adjoining 3.8 acres available, subdividable. Full details at www.astroworks.com/dosastro.html

REAL ESTATE: Land and homes for sale in Southern Utah's high desert – the second darkest place in North America. Noted for deep sky viewing. Properties are located between Bryce Canyon and Capitol Reef National Parks. Small remote communities surrounded by 97% government lands. Electricity, water, internet access and complete comfort while living in the wilderness! Homes on the market now ranging in price from \$190,000 to \$470,000. Land ranging in size from 2 to 47 acres priced from \$48,000 to \$350,000, all with exceptional views of the landscape and the sky. For more information, visit www.bouldermountainrealty.com or call Cathy Bagley, Broker, Torrey, Utah, 435-425-3200.

MAJOR \$200,000 PRICE REDUCTION! Stunning, unique, one-of-a-kind research grade 12-inch f12.2 D&G refractor of superb optical quality (plus companion telescopes) on unique, custom-made Byers Series III mounting. Details in February 2013 issue of S&T, pp 66-69. See more details (plus a video) on SkyandTelescope.com's online Marketplace under "refractors." Entire package now offered at \$595,000. Contact Ed Noffsinger: TheDigmaModel@aol.com or 831-427-1011.

NEW SOLAR HOME on 20 acres, 4 miles from Portal, Arizona. Quality PV system. 16" wide masonry construction. 1,134-sq-ft plus foundation for guest house or observatory. 360-degree views. Dark skies. Privacy. \$207,000. Phone: 575-557-0527.

FOR RENT: 3 BR/2BA fully furnished adobe home in ARIZONA SKY VILLAGE in Portal, AZ. Observe and photograph under the darkest, clearest and most transparent skies with astronomers from all over the world. World class birding, too! irkitzman@gmail.com www.arizona-dreaming.com.

SKY & TELESCOPE COLLECTION: I wish to donate my Sky & Telescope collection, 1945 – present, to a non-profit astronomical or educational organization for educational purposes. Contact: Wade Ortel, 66 Silver Lake Ave., Wakefield, RI 02879-4240

Classified ads are for the sale and purchase of noncommercial merchandise, unique items, or job offers. The rate is \$1.50 per word; minimum charge of \$24; payment must accompany order. Closing date is 15th of third month before publication date.

SKY
& TELESCOPE

Available on
Apple iPad



SkyandTelescope.com/app

If you're a current print subscriber enjoying your free digital edition of S&T on a desktop or laptop computer, you can now get a free iPad edition by downloading the Sky & Telescope app at the iTunes App Store. Digital issues include links to bonus audio interviews, videos, and image galleries.



Available on the
App Store

Digital issues are free for current print subscribers. If you're not a print subscriber, a monthly iPad subscription is \$3.99 per issue (\$2 off the U.S. newsstand price); a year's subscription is \$37.99.

Product Locator

AUTOGUIDERS

Santa Barbara Instrument Group (Page 3)
SBIG.com
613-225-2732

BINOCULARS

Meade (Page 7, 27)
Meade.com
800-919-4047 | 949-451-1450

CAMERAS

Apogee Imaging Systems (Page 19)
CCD.com
916-218-7450

Finger Lakes Instrumentation (Page 13)
FLIcamera.com
585-624-3760

Santa Barbara Instrument Group (Page 3)
SBIG.com
613-225-2732

EYEPIECES

Explore Scientific - Bresser (Page 42, 88)
ExploreScientific.com
888-599-7597

Meade (Page 7, 27)
Meade.com
800-919-4047 | 949-451-1450

Tele Vue (Page 2)
TeleVue.com
845-469-4551

FILTERS

Finger Lakes Instrumentation (Page 13)
FLIcamera.com
585-624-3760

Meade (Page 7, 27)
Meade.com
800-919-4047 | 949-451-1450

Tele Vue (Page 2)
TeleVue.com
845-469-4551

FOCUSERS

Finger Lakes Instrumentation (Page 13)
FLIcamera.com
585-624-3760

MOUNTS

iOptron (Page 9)
iOptron.com
866-399-4587

Mathis Instruments (Page 81)
mathis-instruments.com
925-838-1487

Meade (Page 7, 27)
Meade.com
800-919-4047 | 949-451-1450

Paramount (Page 87)
Bisque.com
303-278-4478

PlaneWave Instruments (Page 82)
PlaneWave.com
310-639-1662

Tele Vue (Page 2)
TeleVue.com
845-469-4551

OBSERVATORIES

Observe-Dome Laboratories (Page 42)
Observe-dome.com
800-647-5364

Oceanside Photo & Telescope (Page 17)
Optcorp.com
800-483-6287

SOFTWARE

Fisch Image Lab (Page 42, 88)
ExploreScientific.com
888-599-7597

Software Bisque (Page 87)
Bisque.com
303-278-4478

TELESCOPES

Explore Scientific - Bresser (Page 42, 88)
ExploreScientific.com
888-599-7597

iOptron (Page 9)
iOptron.com
866-399-4587

Meade (Page 7, 27)
Meade.com
800-919-4047 | 949-451-1450

PlaneWave Instruments (Page 82)
PlaneWave.com
310-639-1662

Sky-Watcher USA (Page 11)
SkyWatcherUSA.com
310-803-5953

Tele Vue (Page 2)
TeleVue.com
845-469-4551

Dealer Locator

CALIFORNIA

Oceanside Photo & Telescope
(Page 17)
Optcorp.com
800-483-6287

CALIFORNIA

Woodland Hills (Page 59)
Telescopes.net
818-347-2270

OKLAHOMA

Astronomics (Page 69)
Astronomics.com
800-422-7876

TEXAS

Texas Nautical Repair, Inc.
(Page 59)
TakahashiAmerica.com
713-529-3551

To advertise on this page, please contact Peter Hardy at 617-758-0243, or Ads@SkyandTelescope.com

Index to Advertisers

Apogee Imaging Systems Inc.	19	Nova Optical Systems	81
Ash Manufacturing Co., Inc.	79	Observe-Dome Laboratories	42
Astro-Physics, Inc.	82	Obsession	69
Astronomics	69	Oceanside Photo & Telescope	17
Bob's Knobs	80	Optic Wave Laboratories	81
CNC Parts Supply, Inc.	80	Orion	15
DiscMounts, Inc.	81	Peterson Engineering Corp.	80
Durango Skies.	81	PlaneWave Instruments	82
Explore Scientific - Bresser	42, 88	PreciseParts	80
Finger Lakes Instrumentation, LLC	13	Santa Barbara Instrument Group	3
Foster Systems	81	<i>Sky & Telescope</i>	69, 74, 79, 82-83
Glatter Instruments	80	Sky-Watcher USA.	11
Goto USA, Inc.	5	Software Bisque.	87
Gutekunst Optiksysteme	69	StellarVue.	82
International Dark-Sky Association	81	Technical Innovations.	80-81
iOptron	9	Tele Vue	2
Jim's Mobile, Inc.	82	Texas Nautical Repair, Inc.	59
Kitt Peak.	59	The Teaching Company	41
Knightware.	81	TravelQuest	83
Lunatico Astronomia	80	University Optics, Inc.	81
Lunt	42	Willmann-Bell, Inc.	81
Mathis Instruments	81	Woodland Hills	59
Meade	7, 27		



SkyandTelescope.com

800-253-0245

IN THE NEXT ISSUE

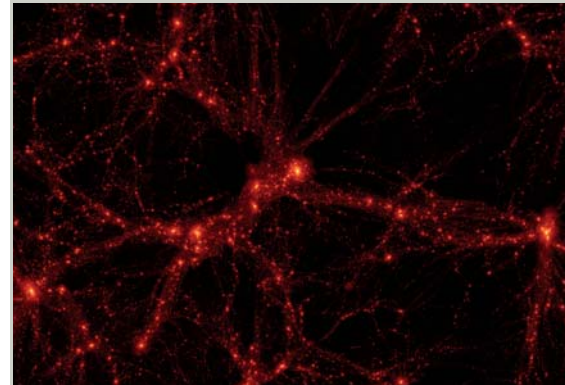

Cosmic Voids

The emptiest parts of the universe may hold secrets to dark matter and dark energy.

Seeing Minor Moons

S&T shares tips on how to observe challenging planetary satellites.

Mastering Your Go To Mount

A veteran observer discusses how to make the most of these modern marvels.



21st-Century Astrophotography

We look at recent trends in deep-sky imaging by amateur astronomers.

On newsstands December 30th!



Find us on
Facebook & Twitter



Lights Out, America!

We need new strategies to bring back the night.

WE NEED YOUR HELP to change America's nighttime experience. As most *S&T* readers know, light pollution is excessive or inappropriate light at night. Speakers often lecture astronomy clubs, and writers sometimes rail against light polluters on the internet. Their audiences generally applaud politely, but then it's over. Surprisingly, the most apathetic audience is our own astronomical community. Amateur and professional astronomers rarely get involved. They complain about light pollution but don't act.

Is the problem apathy or lack of leadership? Astronomers tend to avoid rocking the boat — sometimes to their own detriment. This must change. Light pollution affects couch potatoes as much as everybody else. But the two of us won't sit by and do nothing.

Light pollution is a serious and well-documented problem that goes far beyond astronomy. Scientific studies show a higher incidence of breast cancer in light-polluted

areas. Like smoking, light pollution doesn't induce cancer in everyone. But like smoking, light pollution increases the incidence of cancer, which means it can kill human beings (*S&T*: Sept. 2011, p. 86).

So get involved. Act as if you're trying to save your own life. For 20 years the International Dark-Sky Association has called for better light fixtures to reduce light pollution. The IDA's strategy has had limited success in a few areas, but light pollution continues to worsen across the U.S. So let's do what France is doing. The French government has asked its citizens to turn off all unnecessary indoor and outdoor lights between midnight and dawn. In its first year, this Lights Out initiative has reduced France's energy consumption from nocturnal light pollution by a reported 9%. To reduce America's light pollution, *turn the lights out*. Let's do it now! Here's how:

First, make alliances. Enlist others to our cause so the campaign won't be con-

strued as a tyranny by a minority of elitist astronomers and tree huggers. Tie our message to broader concerns about energy costs, the environment, and climate change. The public is sympathetic. People understand waste, pollution, and environmental damage. Show them the pictures and the numbers. Light changes nocturnal ecosystems and harms migratory animals. Be prepared to address public concerns about safety and security. Inform people that criminals need light at night.

Second, let's get on the airwaves with short, high-impact messages about light pollution's cost in dollars, disease, and environmental damage. Spread the message on local network television using 15-second commercial spots. It's inexpensive and it works. Model commercials on those aired by anti-tobacco forces. The consequences of light pollution are shocking: light pollution kills people, harms animals, and degrades ecosystems. Spread the message far and wide.

We can win the day and bring back the night. Light pollution is one of the easiest environmental problems to cure: simply turn off unnecessary lights (meaning almost all of them), and properly shield the rest. This is not about plunging communities into the dark, but creating a better, healthier world for every living thing. Educate the people and they will act. If the French can do this, so can we.

For more information, visit our website, LightsOutAmerica.net. ♦

Bob Guzauskas, a dentist, is a member of the Astronomical Society of the Palm Beaches and the Astronomical League. Colin Henshaw is a fellow of the Royal Astronomical Society and a member of the British Astronomical Association.



might·y /mī'tē/

(adj.) Possessing great and impressive power or strength, especially on account of size.



Introducing the Paramount Mighty

Experience Paramount performance in a grab-and-go mount. Tipping the scales at a mere 34 lbs (15 kg), the Paramount Mighty deftly carries up to 50 lbs (23 kg) of telescope and accessories. Let the Paramount Mighty be a trusted companion in all your digital imaging pursuits. At \$6,000, the Paramount is now within reach. Grab yours today.

PARAMOUNT

MYT

THE ROBOTIC TELESCOPE MOUNT ENGINEERED TO GO WHERE YOU GO.

FIND YOUR SPACE

BISQUE.COM





EXPLORE[®]
SCIENTIFIC

With true-diffraction limited optics and 152mm of aperture, this premium telescope offers limitless possibilities for a lifetime of exploration. Astrophotographer Mike Wiles and his ED152 captured this image of the swirling beauty of galaxy M106, which is about 23 million light years away. Full of rich structural details of the galaxy's tumultuous core and round pinpoint stars that fill the field, the final 30 hour exposure rivals images of the same object from many professional observatories. The amazing quality comes from the stunning raw details that are harnessed by the ED152's diffraction-limited optics, which are made of precision polished ED glass with enhanced multi-layer deposition coatings. The superior optics are complemented by a well-executed design and a lightweight carbon fiber tube for demanding visual work and imaging.

What will you discover?

explorescientific.com – 866.252.3811

**Diffraction Limited –
without limits**

*Mount and Eyepieces
sold separately*

©2014 Explore Scientific